



FULLY EXECUTED - CHANGE 3
Contract Number: 4400016263
Original Contract Effective Date: 11/18/2016
Contract Change Date: 10/02/2020
Valid From: 12/01/2016 To: 11/30/2021

All using Agencies of the Commonwealth, Participating Political
Subdivision, Authorities, Private Colleges and Universities

Purchasing Agent

Name: Constance Ralph
Phone: 717-703-2931
Fax: 717-783-6241

Your SAP Vendor Number with us: 136083

Supplier Name/Address:
FIVE STAR INTERNATIONAL LLC
1810 S 19TH ST
HARRISBURG PA 17104-3205 US

Please Deliver To:

To be determined at
the time of the Purchase Order
unless specified below.

Supplier Phone Number: 717-986-1500
Supplier Fax Number: 717-986-1510

Contract Name:
Highway Support Vehicles Parent

Payment Terms
NET 30

Solicitation No.: _____ Issuance Date: _____
Supplier Bid or Proposal No. (if applicable): _____ Solicitation Submission Date: _____

This contract is comprised of: The above referenced Solicitation, the Supplier's Bid or Proposal, and any documents attached to this Contract or incorporated by reference.

Item	Material/Service Desc	Qty	UOM	Price	Per Unit	Total
*** Validity Period Changed ***						
2	LOT 2 3000 gal OIL DISTRIBUTOR Internat	0.000	Each	240,418.50	1	0.00
	<i>Valid from 11/07/2016 to 11/30/2018</i>					
	Price(Contract/Bid)	233,416.00	USD	1	EA	
	<i>Valid from 12/01/2018 to 12/31/9999</i>					
	Price(Contract/Bid)	240,418.50	USD	1	EA	

Information:	

Supplier's Signature _____	Title _____
Printed Name _____	Date _____

**FULLY EXECUTED - CHANGE 3**

Contract Number: 4400016263

Original Contract Effective Date: 11/18/2016

Contract Change Date: 10/02/2020

Valid From: 12/01/2016 To: 11/30/2021

Supplier Name:

FIVE STAR INTERNATIONAL LLC

Item	Material/Service Desc	Qty	UOM	Price	Per Unit	Total
Item Text						
3000 gal OIL DISTRIBUTOR: CONV. CAB TANDEM TRUCK CHASSIS WITH OIL DISTRIBUTOR BODY, 3000 gallon, with AUTOMATIC TRANSMISSION, per PA DOT specification 057700.						
CHASSIS MAKE/MODEL: International/ 7600 SFA 6x4						
GVWR:66,000 FRONT GAWR:20,000 REAR GAWR:46,000						
REAR AXLE MAKE/MODEL:Meritor/ RT-46-164P						
ENGINE/MAKE/MODEL/HP/TORQUE: Navistar/N13/430/1550						
FUEL TANK CAPACITY:100 gallons						
TRANSMISSION MAKE/MODEL: Allison / 4500RDS 6 sp/ Auxillary Fuller AT-1202 2 sp						

*** Validity Period Changed ***						
3	LOT 2 OPTION HEATED MATERIAL PUMP	0.000	Each	1,751.00	1	0.00
Valid from 11/07/2016 to 11/30/2018						
Price(Contract/Bid) 1,700.00 USD 1 EA						
Valid from 12/01/2018 to 12/31/9999						
Price(Contract/Bid) 1,751.00 USD 1 EA						

*** Validity Period Changed ***						
4	LOT 5-38,000 # Pony Truck 20' body Inter	0.000	Each	128,427.60	1	0.00
Valid from 11/07/2016 to 11/30/2018						
Price(Contract/Bid) 124,687.00 USD 1 EA						
Valid from 12/01/2018 to 12/31/9999						
Price(Contract/Bid) 128,427.60 USD 1 EA						
Item Text						
38,000 # GVWR Pony Truck with automatic transmission and 20' body, pursuant to PA DOT specification 062300.						
TRANSMISSION MAKE/MODEL: Allison / 3000RDS 6 sp						

*** Validity Period Changed ***						
5	LOT 5-38,000 # Pony Truck 24' body Inter	0.000	Each	129,576.10	1	0.00
Valid from 11/07/2016 to 11/30/2018						
Price(Contract/Bid) 125,802.00 USD 1 EA						
Valid from 12/01/2018 to 12/31/9999						
Price(Contract/Bid) 129,576.10 USD 1 EA						
Item Text						
38,000 # GVWR Pony Truck with automatic transmission and 24' body, pursuant to PA DOT specification 062700.						
TRANSMISSION MAKE/MODEL: Allison / 3000RDS 6 sp						

Information:

**FULLY EXECUTED - CHANGE 3**

Contract Number: 4400016263

Original Contract Effective Date: 11/18/2016

Contract Change Date: 10/02/2020

Valid From: 12/01/2016 To: 11/30/2021

Supplier Name:

FIVE STAR INTERNATIONAL LLC

Item	Material/Service Desc	Qty	UOM	Price	Per Unit	Total
*** Validity Period Changed ***						
6	LOT 5 OPTION ENGINE COMPRESSION BRAKE	0.000	Each	1,158.75	1	0.00
	<i>Valid from 11/07/2016 to 11/30/2018</i>					
	Price(Contract/Bid)	1,125.00	USD	1 EA		
	<i>Valid from 12/01/2018 to 12/31/9999</i>					
	Price(Contract/Bid)	1,158.75	USD	1 EA		
*** Validity Period Changed ***						
7	LOT 5 OPTION TRAILER TOW HITCH	0.000	Each	525.30	1	0.00
	<i>Valid from 11/07/2016 to 11/30/2018</i>					
	Price(Contract/Bid)	510.00	USD	1 EA		
	<i>Valid from 12/01/2018 to 12/31/9999</i>					
	Price(Contract/Bid)	525.30	USD	1 EA		
*** Validity Period Changed ***						
8	LOT 6 Fuel Supply Truck Single Tank Inte	0.000	Each	171,531.10	1	0.00
	<i>Valid from 11/07/2016 to 11/30/2018</i>					
	Price(Contract/Bid)	166,535.00	USD	1 EA		
	<i>Valid from 12/01/2018 to 12/31/9999</i>					
	Price(Contract/Bid)	171,531.10	USD	1 EA		
Item Text						
Truck, Fuel Supply, with 1,800 gallon (minimum) tank body, diesel, automatic transmission, pursuant to PA DOT specification 056100						
CHASSIS MAKE/MODEL: International/ 7400 SFA 4x2						
BODY MAKE/MODEL: Amthor/ Cardinal						
TANKER CAPACITY: 2200 gallons						
GVWR: 39,000 FRONT GAWR: 16,000 REAR GAWR: 23,000						
REAR AXLE MAKE/MODEL: Meritor / RS-23-160						
FRAME RBM: 2,037,600						
ENGINE/MAKE/MODEL/HP/TORQUE: Cummins/ ISL9/ 330/ 1000						
TRANSMISSION MAKE/MODEL: Allison/ 3500RDS 6sp						
FUEL TANK CAPACITY: 80 gallons						
*** Validity Period Changed ***						
9	LOT 6 OPTION ENGINE COMPRESSION BRAKE	0.000	Each	412.00	1	0.00

Information:

**FULLY EXECUTED - CHANGE 3**

Contract Number: 4400016263

Original Contract Effective Date: 11/18/2016

Contract Change Date: 10/02/2020

Valid From: 12/01/2016 To: 11/30/2021

Supplier Name:

FIVE STAR INTERNATIONAL LLC

Item	Material/Service Desc	Qty	UOM	Price	Per Unit	Total
	<i>Valid from 11/07/2016 to 11/30/2018</i>					
	Price(Contract/Bid)	400.00	USD 1 EA			
	<i>Valid from 12/01/2018 to 12/31/9999</i>					
	Price(Contract/Bid)	412.00	USD 1 EA			

*** Validity Period Changed ***						
10	LOT 7 Fuel Supply Truck Dual Tank Intern	0.000	Each	188,989.60	1	0.00
	<i>Valid from 11/07/2016 to 11/30/2018</i>					
	Price(Contract/Bid)	183,485.00	USD 1 EA			
	<i>Valid from 12/01/2018 to 12/31/9999</i>					
	Price(Contract/Bid)	188,989.60	USD 1 EA			

Item Text						
Truck, Fuel Supply with 1,800 gallon (minimum) tank body with gas and diesel compartments and automatic transmission, pursuant to PA DOT specification 056500						
CHASSIS MAKE/MODEL: International/ 7400 SFA 4x2						
BODY MAKE/MODEL: Amthor/ Cardinal						
TANKER CAPACITY: 2100 gallons						
GVWR: 39,000 FRONT GAWR: 16,000 REAR GAWR: 23,000						
REAR AXLE MAKE/MODEL: Meritor / RS-23-160						
FRAME RBM: 2,037,600						
ENGINE/MAKE/MODEL/HP/TORQUE: Cummins/ ISL9/ 330/ 1000						
TRANSMISSION MAKE/MODEL: Allison/ 3500RDS 6sp						
FUEL TANK CAPACITY: 80 gallons						

*** Validity Period Changed ***						
11	LOT 7 OPTION ENGINE COMPRESSION BRAKE	0.000	Each	412.00	1	0.00
	<i>Valid from 11/07/2016 to 11/30/2018</i>					
	Price(Contract/Bid)	400.00	USD 1 EA			
	<i>Valid from 12/01/2018 to 12/31/9999</i>					
	Price(Contract/Bid)	412.00	USD 1 EA			

*** Validity Period Changed ***						
12	Training	0.000		0.00	1	0.00

General Requirements for all Items:**Information:**



FULLY EXECUTED - CHANGE 3
Contract Number: 4400016263
Original Contract Effective Date: 11/18/2016
Contract Change Date: 10/02/2020
Valid From: 12/01/2016 To: 11/30/2021

Supplier Name:
FIVE STAR INTERNATIONAL LLC

Header Text

This contract is from IFB # 6100040097 and incorporates all terms and conditions of this IFB.

Contact Information:

Ralph Constance
Commodity Specialist
555 Walnut St., 6th Floor
Harrisburg, PA 17101-1914
717.703.2931
rconstance@pa.gov

No further information for this Contract

Information:



FULLY EXECUTED - CHANGE 2
Contract Number: 4400016263
Original Contract Effective Date: 11/18/2016
Contract Change Date: 05/20/2019
Valid From: 12/01/2016 To: 11/30/2020

All using Agencies of the Commonwealth, Participating Political
Subdivision, Authorities, Private Colleges and Universities

Purchasing Agent

Name: Constance Ralph
Phone: 717-703-2931
Fax: 717-783-6241

Your SAP Vendor Number with us: 136083

Supplier Name/Address:
FIVE STAR INTERNATIONAL LLC
1810 S 19TH ST
HARRISBURG PA 17104-3205 US

Supplier Phone Number: 717-986-1500
Supplier Fax Number: 717-986-1510

Please Deliver To:

To be determined at
the time of the Purchase Order
unless specified below.

Contract Name:
Highway Support Vehicles Parent

Payment Terms
NET 30

Solicitation No.: _____ Issuance Date: _____
Supplier Bid or Proposal No. (if applicable): _____ Solicitation Submission Date: _____

This contract is comprised of: The above referenced Solicitation, the Supplier's Bid or Proposal, and any documents attached to this Contract or incorporated by reference.

Item	Material/Service Desc	Qty	UOM	Price	Per Unit	Total
*** Validity Period Changed ***						
2	LOT 2 3000 gal OIL DISTRIBUTOR Internat	0.000	Each	240,418.50	1	0.00
	<i>Valid from 11/07/2016 to 11/30/2018</i>					
	Price(Contract/Bid)	233,416.00	USD	1	EA	
	<i>Valid from 12/01/2018 to 12/31/9999</i>					
	Price(Contract/Bid)	240,418.50	USD	1	EA	

Information:

Supplier's Signature _____
Printed Name _____

Title _____
Date _____

**FULLY EXECUTED - CHANGE 2**

Contract Number: 4400016263

Original Contract Effective Date: 11/18/2016

Contract Change Date: 05/20/2019

Valid From: 12/01/2016 To: 11/30/2020

Supplier Name:

FIVE STAR INTERNATIONAL LLC

Item	Material/Service Desc	Qty	UOM	Price	Per Unit	Total
Item Text						
3000 gal OIL DISTRIBUTOR: CONV. CAB TANDEM TRUCK CHASSIS WITH OIL DISTRIBUTOR BODY, 3000 gallon, with AUTOMATIC TRANSMISSION, per PA DOT specification 057700.						
CHASSIS MAKE/MODEL: International/ 7600 SFA 6x4						
GVWR:66,000 FRONT GAWR:20,000 REAR GAWR:46,000						
REAR AXLE MAKE/MODEL:Meritor/ RT-46-164P						
ENGINE/MAKE/MODEL/HP/TORQUE: Navistar/N13/430/1550						
FUEL TANK CAPACITY:100 gallons						
TRANSMISSION MAKE/MODEL: Allison / 4500RDS 6 sp/ Auxillary Fuller AT-1202 2 sp						

*** Validity Period Changed ***						
3	LOT 2 OPTION HEATED MATERIAL PUMP	0.000	Each	1,751.00	1	0.00
Valid from 11/07/2016 to 11/30/2018						
Price(Contract/Bid) 1,700.00 USD 1 EA						
Valid from 12/01/2018 to 12/31/9999						
Price(Contract/Bid) 1,751.00 USD 1 EA						

*** Validity Period Changed ***						
4	LOT 5-38,000 # Pony Truck 20' body Inter	0.000	Each	128,427.60	1	0.00
Valid from 11/07/2016 to 11/30/2018						
Price(Contract/Bid) 124,687.00 USD 1 EA						
Valid from 12/01/2018 to 12/31/9999						
Price(Contract/Bid) 128,427.60 USD 1 EA						
Item Text						
38,000 # GVWR Pony Truck with automatic transmission and 20' body, pursuant to PA DOT specification 062300.						
TRANSMISSION MAKE/MODEL: Allison / 3000RDS 6 sp						

*** Validity Period Changed ***						
5	LOT 5-38,000 # Pony Truck 24' body Inter	0.000	Each	129,576.10	1	0.00
Valid from 11/07/2016 to 11/30/2018						
Price(Contract/Bid) 125,802.00 USD 1 EA						
Valid from 12/01/2018 to 12/31/9999						
Price(Contract/Bid) 129,576.10 USD 1 EA						
Item Text						
38,000 # GVWR Pony Truck with automatic transmission and 24' body, pursuant to PA DOT specification 062700.						
TRANSMISSION MAKE/MODEL: Allison / 3000RDS 6 sp						

Information:

**FULLY EXECUTED - CHANGE 2**

Contract Number: 4400016263

Original Contract Effective Date: 11/18/2016

Contract Change Date: 05/20/2019

Valid From: 12/01/2016 To: 11/30/2020

Supplier Name:

FIVE STAR INTERNATIONAL LLC

Item	Material/Service Desc	Qty	UOM	Price	Per Unit	Total
*** Validity Period Changed ***						
6	LOT 5 OPTION ENGINE COMPRESSION BRAKE	0.000	Each	1,158.75	1	0.00
	<i>Valid from 11/07/2016 to 11/30/2018</i>					
	Price(Contract/Bid)	1,125.00	USD	1 EA		
	<i>Valid from 12/01/2018 to 12/31/9999</i>					
	Price(Contract/Bid)	1,158.75	USD	1 EA		
*** Validity Period Changed ***						
7	LOT 5 OPTION TRAILER TOW HITCH	0.000	Each	525.30	1	0.00
	<i>Valid from 11/07/2016 to 11/30/2018</i>					
	Price(Contract/Bid)	510.00	USD	1 EA		
	<i>Valid from 12/01/2018 to 12/31/9999</i>					
	Price(Contract/Bid)	525.30	USD	1 EA		
*** Validity Period Changed ***						
8	LOT 6 Fuel Supply Truck Single Tank Inte	0.000	Each	171,531.10	1	0.00
	<i>Valid from 11/07/2016 to 11/30/2018</i>					
	Price(Contract/Bid)	166,535.00	USD	1 EA		
	<i>Valid from 12/01/2018 to 12/31/9999</i>					
	Price(Contract/Bid)	171,531.10	USD	1 EA		
Item Text						
Truck, Fuel Supply, with 1,800 gallon (minimum) tank body, diesel, automatic transmission, pursuant to PA DOT specification 056100						
CHASSIS MAKE/MODEL: International/ 7400 SFA 4x2						
BODY MAKE/MODEL: Amthor/ Cardinal						
TANKER CAPACITY: 2200 gallons						
GVWR: 39,000 FRONT GAWR: 16,000 REAR GAWR: 23,000						
REAR AXLE MAKE/MODEL: Meritor / RS-23-160						
FRAME RBM: 2,037,600						
ENGINE/MAKE/MODEL/HP/TORQUE: Cummins/ ISL9/ 330/ 1000						
TRANSMISSION MAKE/MODEL: Allison/ 3500RDS 6sp						
FUEL TANK CAPACITY: 80 gallons						
*** Validity Period Changed ***						
9	LOT 6 OPTION ENGINE COMPRESSION BRAKE	0.000	Each	412.00	1	0.00

Information:

**FULLY EXECUTED - CHANGE 2**

Contract Number: 4400016263

Original Contract Effective Date: 11/18/2016

Contract Change Date: 05/20/2019

Valid From: 12/01/2016 To: 11/30/2020

Supplier Name:

FIVE STAR INTERNATIONAL LLC

Item	Material/Service Desc	Qty	UOM	Price	Per Unit	Total
	<i>Valid from 11/07/2016 to 11/30/2018</i>					
	Price(Contract/Bid)	400.00	USD 1 EA			
	<i>Valid from 12/01/2018 to 12/31/9999</i>					
	Price(Contract/Bid)	412.00	USD 1 EA			

*** Validity Period Changed ***						
10	LOT 7 Fuel Supply Truck Dual Tank Intern	0.000	Each	188,989.60	1	0.00
	<i>Valid from 11/07/2016 to 11/30/2018</i>					
	Price(Contract/Bid)	183,485.00	USD 1 EA			
	<i>Valid from 12/01/2018 to 12/31/9999</i>					
	Price(Contract/Bid)	188,989.60	USD 1 EA			

Item Text						
Truck, Fuel Supply with 1,800 gallon (minimum) tank body with gas and diesel compartments and automatic transmission, pursuant to PA DOT specification 056500						
CHASSIS MAKE/MODEL: International/ 7400 SFA 4x2						
BODY MAKE/MODEL: Amthor/ Cardinal						
TANKER CAPACITY: 2100 gallons						
GVWR: 39,000 FRONT GAWR: 16,000 REAR GAWR: 23,000						
REAR AXLE MAKE/MODEL: Meritor / RS-23-160						
FRAME RBM: 2,037,600						
ENGINE/MAKE/MODEL/HP/TORQUE: Cummins/ ISL9/ 330/ 1000						
TRANSMISSION MAKE/MODEL: Allison/ 3500RDS 6sp						
FUEL TANK CAPACITY: 80 gallons						

*** Validity Period Changed ***						
11	LOT 7 OPTION ENGINE COMPRESSION BRAKE	0.000	Each	412.00	1	0.00
	<i>Valid from 11/07/2016 to 11/30/2018</i>					
	Price(Contract/Bid)	400.00	USD 1 EA			
	<i>Valid from 12/01/2018 to 12/31/9999</i>					
	Price(Contract/Bid)	412.00	USD 1 EA			

*** Validity Period Changed ***						
12	Training	0.000		0.00	1	0.00

General Requirements for all Items:**Information:**



FULLY EXECUTED - CHANGE 2
Contract Number: 4400016263
Original Contract Effective Date: 11/18/2016
Contract Change Date: 05/20/2019
Valid From: 12/01/2016 To: 11/30/2020

Supplier Name:
FIVE STAR INTERNATIONAL LLC

Header Text

This contract is from IFB # 6100040097 and incorporates all terms and conditions of this IFB.

Contact Information:

Ralph Constance
Commodity Specialist
555 Walnut St., 6th Floor
Harrisburg, PA 17101-1914
717.703.2931
rconstance@pa.gov

No further information for this Contract

Information:



FULLY EXECUTED - CHANGE 1
Contract Number: 4400016263
Original Contract Effective Date: 11/18/2016
Contract Change Date: 05/29/2018
Valid From: 12/01/2016 To: 11/30/2019

All using Agencies of the Commonwealth, Participating Political
Subdivision, Authorities, Private Colleges and Universities

Purchasing Agent

Name: Constance Ralph
Phone: 717-703-2931
Fax: 717-783-6241

Your SAP Vendor Number with us: 136083

Supplier Name/Address:
FIVE STAR INTERNATIONAL LLC
1810 S 19TH ST
HARRISBURG PA 17104-3205 US

Please Deliver To:

To be determined at
the time of the Purchase Order
unless specified below.

Supplier Phone Number: 717-986-1500

Supplier Fax Number: 717-986-1510

Contract Name:
Highway Support Vehicles Parent

Payment Terms
NET 30

Solicitation No.: _____ Issuance Date: _____
Supplier Bid or Proposal No. (if applicable): _____ Solicitation Submission Date: _____

This contract is comprised of: The above referenced Solicitation, the Supplier's Bid or Proposal, and any documents attached to this Contract or incorporated by reference.

Item	Material/Service Desc	Qty	UOM	Price	Per Unit	Total
2	LOT 2 3000 gal OIL DISTRIBUTOR Internat	0.000	Each	233,416.00	1	0.00
	<i>Valid from 11/07/2016 to 11/30/2018</i>					
	Price(Contract/Bid)	233,416.00	USD	1	EA	
	<i>Valid from 12/01/2018 to 12/31/9999</i>					
	Price(Contract/Bid)	240,418.50	USD	1	EA	

Information:

Supplier's Signature _____
Printed Name _____

Title _____
Date _____



FULLY EXECUTED - CHANGE 1

Contract Number: 4400016263

Original Contract Effective Date: 11/18/2016

Contract Change Date: 05/29/2018

Valid From: 12/01/2016 To: 11/30/2019

Supplier Name:

FIVE STAR INTERNATIONAL LLC

Item	Material/Service Desc	Qty	UOM	Price	Per Unit	Total
Item Text						
3000 gal OIL DISTRIBUTOR: CONV. CAB TANDEM TRUCK CHASSIS WITH OIL DISTRIBUTOR BODY, 3000 gallon, with AUTOMATIC TRANSMISSION, per PA DOT specification 057700.						
CHASSIS MAKE/MODEL: International/ 7600 SFA 6x4						
GVWR:66,000 FRONT GAWR:20,000 REAR GAWR:46,000						
REAR AXLE MAKE/MODEL:Meritor/ RT-46-164P						
ENGINE/MAKE/MODEL/HP/TORQUE: Navistar/N13/430/1550						
FUEL TANK CAPACITY:100 gallons						
TRANSMISSION MAKE/MODEL: Allison / 4500RDS 6 sp/ Auxillary Fuller AT-1202 2 sp						
Field Changed: PRICE						
Old Value: 240418.50						
New Value: 233416.00						

3	LOT 2 OPTION HEATED MATERIAL PUMP	0.000	Each	1,700.00	1	0.00
	<i>Valid from 11/07/2016 to 11/30/2018</i>					
	Price(Contract/Bid)	1,700.00	USD	1	EA	
	<i>Valid from 12/01/2018 to 12/31/9999</i>					
	Price(Contract/Bid)	1,751.00	USD	1	EA	
Field Changed: PRICE						
Old Value: 1751.00						
New Value: 1700.00						

4	LOT 5-38,000 # Pony Truck 20' body Inter	0.000	Each	124,687.00	1	0.00
	<i>Valid from 11/07/2016 to 11/30/2018</i>					
	Price(Contract/Bid)	124,687.00	USD	1	EA	
	<i>Valid from 12/01/2018 to 12/31/9999</i>					
	Price(Contract/Bid)	128,427.60	USD	1	EA	
Item Text						
38,000 # GVWR Pony Truck with automatic transmission and 20' body, pursuant to PA DOT specification 062300.						
TRANSMISSION MAKE/MODEL: Allison / 3000RDS 6 sp						
Field Changed: PRICE						
Old Value: 128427.60						
New Value: 124687.00						

5	LOT 5-38,000 # Pony Truck 24' body Inter	0.000	Each	125,802.00	1	0.00
	<i>Valid from 11/07/2016 to 11/30/2018</i>					
	Price(Contract/Bid)	125,802.00	USD	1	EA	

Information:	
---------------------	--

**FULLY EXECUTED - CHANGE 1**

Contract Number: 4400016263

Original Contract Effective Date: 11/18/2016

Contract Change Date: 05/29/2018

Valid From: 12/01/2016 To: 11/30/2019

Supplier Name:

FIVE STAR INTERNATIONAL LLC

Item	Material/Service Desc	Qty	UOM	Price	Per Unit	Total
	<i>Valid from 12/01/2018 to 12/31/9999</i>					
	Price(Contract/Bid)	129,576.10	USD	1	EA	
Item Text						
38,000 # GVWR Pony Truck with automatic transmission and 24' body, pursuant to PA DOT specification 062700.						
TRANSMISSION MAKE/MODEL: Allison / 3000RDS 6 sp						
Field Changed: PRICE						
Old Value: 129576.10						
New Value: 125802.00						

6	LOT 5 OPTION ENGINE COMPRESSION BRAKE	0.000	Each	1,125.00	1	0.00
	<i>Valid from 11/07/2016 to 11/30/2018</i>					
	Price(Contract/Bid)	1,125.00	USD	1	EA	
	<i>Valid from 12/01/2018 to 12/31/9999</i>					
	Price(Contract/Bid)	1,158.75	USD	1	EA	
Field Changed: PRICE						
Old Value: 1158.75						
New Value: 1125.00						

7	LOT 5 OPTION TRAILER TOW HITCH	0.000	Each	510.00	1	0.00
	<i>Valid from 11/07/2016 to 11/30/2018</i>					
	Price(Contract/Bid)	510.00	USD	1	EA	
	<i>Valid from 12/01/2018 to 12/31/9999</i>					
	Price(Contract/Bid)	525.30	USD	1	EA	
Field Changed: PRICE						
Old Value: 525.30						
New Value: 510.00						

8	LOT 6 Fuel Supply Truck Single Tank Inte	0.000	Each	166,535.00	1	0.00
	<i>Valid from 11/07/2016 to 11/30/2018</i>					
	Price(Contract/Bid)	166,535.00	USD	1	EA	
	<i>Valid from 12/01/2018 to 12/31/9999</i>					
	Price(Contract/Bid)	171,531.10	USD	1	EA	

Information:



FULLY EXECUTED - CHANGE 1

Contract Number: 4400016263

Original Contract Effective Date: 11/18/2016

Contract Change Date: 05/29/2018

Valid From: 12/01/2016 To: 11/30/2019

Supplier Name:

FIVE STAR INTERNATIONAL LLC

Item	Material/Service Desc	Qty	UOM	Price	Per Unit	Total
Item Text						
Truck, Fuel Supply, with 1,800 gallon (minimum) tank body, diesel, automatic transmission, pursuant to PA DOT specification 056100						
CHASSIS MAKE/MODEL: International/ 7400 SFA 4x2						
BODY MAKE/MODEL: Amthor/ Cardinal						
TANKER CAPACITY: 2200 gallons						
GVWR: 39,000 FRONT GAWR: 16,000 REAR GAWR: 23,000						
REAR AXLE MAKE/MODEL: Meritor / RS-23-160						
FRAME RBM: 2,037,600						
ENGINE/MAKE/MODEL/HP/TORQUE: Cummins/ ISL9/ 330/ 1000						
TRANSMISSION MAKE/MODEL: Allison/ 3500RDS 6sp						
FUEL TANK CAPACITY: 80 gallons						
Field Changed: PRICE						
Old Value: 171531.10						
New Value: 166535.00						

9	LOT 6 OPTION ENGINE COMPRESSION BRAKE	0.000	Each	400.00	1	0.00
	<i>Valid from 11/07/2016 to 11/30/2018</i>					
	Price(Contract/Bid)	400.00	USD	1	EA	
	<i>Valid from 12/01/2018 to 12/31/9999</i>					
	Price(Contract/Bid)	412.00	USD	1	EA	
Field Changed: PRICE						
Old Value: 412.00						
New Value: 400.00						

10	LOT 7 Fuel Supply Truck Dual Tank Intern	0.000	Each	183,485.00	1	0.00
	<i>Valid from 11/07/2016 to 11/30/2018</i>					
	Price(Contract/Bid)	183,485.00	USD	1	EA	
	<i>Valid from 12/01/2018 to 12/31/9999</i>					
	Price(Contract/Bid)	188,989.60	USD	1	EA	

Information:



FULLY EXECUTED - CHANGE 1
Contract Number: 4400016263
Original Contract Effective Date: 11/18/2016
Contract Change Date: 05/29/2018
Valid From: 12/01/2016 To: 11/30/2019

Supplier Name:
FIVE STAR INTERNATIONAL LLC

Item	Material/Service Desc	Qty	UOM	Price	Per Unit	Total
Item Text						
Truck, Fuel Supply with 1,800 gallon (minimum) tank body with gas and diesel compartments and automatic transmission, pursuant to PA DOT specification 056500 CHASSIS MAKE/MODEL: International/ 7400 SFA 4x2 BODY MAKE/MODEL: Amthor/ Cardinal TANKER CAPACITY: 2100 gallons GVWR: 39,000 FRONT GAWR: 16,000 REAR GAWR: 23,000 REAR AXLE MAKE/MODEL: Meritor / RS-23-160 FRAME RBM: 2,037,600 ENGINE/MAKE/MODEL/HP/TORQUE: Cummins/ ISL9/ 330/ 1000 TRANSMISSION MAKE/MODEL: Allison/ 3500RDS 6sp FUEL TANK CAPACITY: 80 gallons Field Changed: PRICE Old Value: 188989.60 New Value: 183485.00						
11	LOT 7 OPTION ENGINE COMPRESSION BRAKE	0.000	Each	400.00	1	0.00
	Valid from 11/07/2016 to 11/30/2018 Price(Contract/Bid) 400.00 USD 1 EA Valid from 12/01/2018 to 12/31/9999 Price(Contract/Bid) 412.00 USD 1 EA					
	Field Changed: PRICE Old Value: 412.00 New Value: 400.00					
12	Training	0.000		0.00	1	0.00

General Requirements for all Items:

Header Text

This contract is from IFB # 6100040097 and incorporates all terms and conditions of this IFB.

Contact Information:

Ralph Constance
Commodity Specialist
555 Walnut St., 6th Floor
Harrisburg, PA 17101-1914
717.703.2931
rconstance@pa.gov
No further information for this Contract

Information:



FULLY EXECUTED
Contract Number: 4400016263
Original Contract Effective Date: 11/18/2016
Valid From: 12/01/2016 To: 11/30/2018

All using Agencies of the Commonwealth, Participating Political
Subdivision, Authorities, Private Colleges and Universities

Purchasing Agent

Name: Constance Ralph
Phone: 717-703-2931
Fax: 717-783-6241

Your SAP Vendor Number with us: 136083

Supplier Name/Address:
FIVE STAR INTERNATIONAL LLC
1810 S 19TH ST
HARRISBURG PA 17104-3205 US

Please Deliver To:

To be determined at
the time of the Purchase Order
unless specified below.

Supplier Phone Number: 717-986-1500
Supplier Fax Number: 717-986-1510

Contract Name:
Highway Support Vehicles Parent

Payment Terms
NET 30

Solicitation No.: _____ Issuance Date: _____
Supplier Bid or Proposal No. (if applicable): _____ Solicitation Submission Date: _____

This contract is comprised of: The above referenced Solicitation, the Supplier's Bid or Proposal, and any documents attached to this Contract or incorporated by reference.

Item	Material/Service Desc	Qty	UOM	Price	Per Unit	Total
2	LOT 2 3000 gal OIL DISTRIBUTOR Internat	0.000	Each	233,416.00	1	0.00
Item Text						
3000 gal OIL DISTRIBUTOR: CONV. CAB TANDEM TRUCK CHASSIS WITH OIL DISTRIBUTOR BODY, 3000 gallon, with AUTOMATIC TRANSMISSION, per PA DOT specification 057700. CHASSIS MAKE/MODEL: International/ 7600 SFA 6x4 GVWR:66,000 FRONT GAWR:20,000 REAR GAWR:46,000 REAR AXLE MAKE/MODEL:Meritor/ RT-46-164P ENGINE/MAKE/MODEL/HP/TORQUE: Navistar/N13/430/1550 FUEL TANK CAPACITY:100 gallons TRANSMISSION MAKE/MODEL: Allison / 4500RDS 6 sp/ Auxillary Fuller AT-1202 2 sp						
3	LOT 2 OPTION HEATED MATERIAL PUMP	0.000	Each	1,700.00	1	0.00

Information:

Supplier's Signature _____
Printed Name _____

Title _____
Date _____



FULLY EXECUTED

Contract Number: 4400016263

Original Contract Effective Date: 11/18/2016

Valid From: 12/01/2016 To: 11/30/2018

Supplier Name:

FIVE STAR INTERNATIONAL LLC

Item	Material/Service Desc	Qty	UOM	Price	Per Unit	Total
4	LOT 5-38,000 # Pony Truck 20' body Inter	0.000	Each	124,687.00	1	0.00
Item Text						
38,000 # GVWR Pony Truck with automatic transmission and 20' body, pursuant to PA DOT specification 062300. TRANSMISSION MAKE/MODEL: Allison / 3000RDS 6 sp						
5	LOT 5-38,000 # Pony Truck 24' body Inter	0.000	Each	125,802.00	1	0.00
Item Text						
38,000 # GVWR Pony Truck with automatic transmission and 24' body, pursuant to PA DOT specification 062700. TRANSMISSION MAKE/MODEL: Allison / 3000RDS 6 sp						
6	LOT 5 OPTION ENGINE COMPRESSION BRAKE	0.000	Each	1,125.00	1	0.00
7	LOT 5 OPTION TRAILER TOW HITCH	0.000	Each	510.00	1	0.00
8	LOT 6 Fuel Supply Truck Single Tank Inte	0.000	Each	166,535.00	1	0.00
Item Text						
Truck, Fuel Supply, with 1,800 gallon (minimum) tank body, diesel, automatic transmission, pursuant to PA DOT specification 056100 CHASSIS MAKE/MODEL: International/ 7400 SFA 4x2 BODY MAKE/MODEL: Amthor/ Cardinal TANKER CAPACITY: 2200 gallons GVWR: 39,000 FRONT GAWR: 16,000 REAR GAWR: 23,000 REAR AXLE MAKE/MODEL: Meritor / RS-23-160 FRAME RBM: 2,037,600 ENGINE/MAKE/MODEL/HP/TORQUE: Cummins/ ISL9/ 330/ 1000 TRANSMISSION MAKE/MODEL: Allison/ 3500RDS 6sp FUEL TANK CAPACITY: 80 gallons						
9	LOT 6 OPTION ENGINE COMPRESSION BRAKE	0.000	Each	400.00	1	0.00
10	LOT 7 Fuel Supply Truck Dual Tank Intern	0.000	Each	183,485.00	1	0.00

Information:	
---------------------	--



FULLY EXECUTED
Contract Number: 4400016263
Original Contract Effective Date: 11/18/2016
Valid From: 12/01/2016 To: 11/30/2018

Supplier Name:
FIVE STAR INTERNATIONAL LLC

Item	Material/Service Desc	Qty	UOM	Price	Per Unit	Total
Item Text						
Truck, Fuel Supply with 1,800 gallon (minimum) tank body with gas and diesel compartments and automatic transmission, pursuant to PA DOT specification 056500 CHASSIS MAKE/MODEL: International/ 7400 SFA 4x2 BODY MAKE/MODEL: Amthor/ Cardinal TANKER CAPACITY: 2100 gallons GVWR: 39,000 FRONT GAWR: 16,000 REAR GAWR: 23,000 REAR AXLE MAKE/MODEL: Meritor / RS-23-160 FRAME RBM: 2,037,600 ENGINE/MAKE/MODEL/HP/TORQUE: Cummins/ ISL9/ 330/ 1000 TRANSMISSION MAKE/MODEL: Allison/ 3500RDS 6sp FUEL TANK CAPACITY: 80 gallons						
11	LOT 7 OPTION ENGINE COMPRESSION BRAKE	0.000	Each	400.00	1	0.00
12	Training	0.000		0.00	1	0.00

General Requirements for all Items:

Header Text

This contract is from IFB # 6100040097 and incorporates all terms and conditions of this IFB.

Contact Information:

Ralph Constance
Commodity Specialist
555 Walnut St., 6th Floor
Harrisburg, PA 17101-1914
717.703.2931
rconstance@pa.gov

No further information for this Contract

Information:

Attachment #1

TRAINING:

Prices for training shall be separate from unit bid price. Training pricing must be submitted with the bid package and will not affect the final outcome of the bid.

Training sessions may or may not be utilized.

FIELD TRAINING SESSIONS

May be performed in any or all of the Regional locations listed (listed below)

Operator/Mechanic:

The successful vendor shall provide services of qualified factory trained technicians for not more than 16 students. Training sessions of not more than 15 hours to train personnel for in-depth preventive maintenance, overhaul and review of the proper usage of parts and service manuals, as well as component/system adjustments that need to be monitored at specified service intervals. Travel, lodging and meal expenses are the responsibility of the awarded vendor.

The successful vendor shall submit a training plan to the Equipment Division for approval within 45 days after receipt of the Purchase Order. The training plan shall consist of course outline, class schedule and material handouts.

The successful vendor shall be responsible for providing all material and training aids as needed.

All training must be coordinated and completed within 60 days after the dates established in the approved training plan unless an extension is mutually agreed to in writing by the Chief of the Fleet Management Division.

All training shall be coordinated with the District Equipment Managers, with the exception of Asphalt related training, which MUST be coordinated with the Statewide Training Coordinator (717) 787-4836, Fax (717) 783-4438.

Attachment #1

PennDOT Operator/Mechanic Training: Complete price per training event; training event is defined as 2 consecutive days of not more than 15 hours for not more than 16 students.

REGION ONE

\$ 2200.00 Per Event

PENNDOT District 1-0
255 Elm Street
P.O. Box 398
Oil City, PA 16301
Phone: (814) 678-7043
Fax: (814) 678-7040

PENNDOT District 2-0
1924-30 Daisy Street
P.O. Box 342
Clearfield, PA 16830
Phone: (814) 765-0504
Fax: (814) 765-0487

PENNDOT District 10-0
2550 Oakland Ave.
P.O. Box 429
Indiana, PA 15701-0429
Phone: (724) 357-2816
Fax: (724) 357-1904

REGION TWO

\$ 2,200.00 Per Event

PENNDOT District 3-0
715 Jordan Avenue
Montoursville, PA 17754
Phone: (570) 368-4217
Fax: (570) 368-4343

PENNDOT District 4-0
P.O. Box 111
Scranton, PA 18501
Phone: (570) 963-4032
Fax: (570) 963-4245

Attachment #1

REGION THREE

\$ 2,200.00 Per Event

PENNDOT District 5-0

1713 Lehigh Street
Allentown, PA 18103-4727
Phone: (610) 798-4184
Fax: (610) 798-4193

PENNDOT District 6-0

7000 Geerdes Blvd.
King of Prussia, PA 19406-1525
Phone: (610) 205-6744
Fax: (610) 205-6909

PENNDOT District 8-0

2140 Herr Street
Harrisburg, PA 17103-1699
Phone: (717) 787-4339
Fax: (717) 772-0975

Equipment Division

17th and Arsenal Blvd.
Harrisburg, Pa. 17120
Phone: (717) 787-1567
Fax: (717) 783-0971

REGION FOUR

\$ 2,200.00 Per Event

PENNDOT District 9-0

1620 North Juniata Street
Hollidaysburg, PA 16648
Phone: (814) 696-7112
Fax: (814) 696-7121

PENNDOT District 11-0

45 Thomas Run Road
Bridgeville, PA 15017
Phone: (412) 429-4942
Fax: (412) 429-5069

PENNDOT District 12-0

P.O. Box 459
North Gallatin Avenue Extension
Uniontown, PA 15401-0459
Phone: (724) 439-7362
Fax: (724) 439-7360

Attachment #1

INSTRUCTOR TRAINING:

\$ 2200.00 Per Event

To be performed on an annual basis (1 time per year) during the length of the contract.

The successful vendor shall provide services of qualified factory trained technicians for not more than 37.5 hours for a maximum of 14 people at the location referenced below. Course shall cover chassis, engine, driveline and electrical systems. Travel, lodging and meal expenses for vendor instructors are the responsibility of the successful vendor.

Equipment Division

17th and Arsenal Blvd.

Harrisburg, Pa. 17120

Phone: (717) 787-1567

Fax: (717) 783-0971

IFB# 6100040097 Highway Support Vehicles

Specification Part 1 IFB# 6100040097

1. **CONTRACT SCOPE/OVERVIEW:** Any Contract resulting from this Bid No. 6100040097 will cover the requirements of The Commonwealth of Pennsylvania for the "Highway Support Vehicles" as cited in the Invitation for Bid (IFB) document.
2. **PRICE ADJUSTMENTS**
 - a. Prices established in the Contract shall remain fixed for the first year of the Contract. Thereafter, Contractor may request a price increase. However, Contractor shall not request, and the Department will not entertain, more than one request for a price increase for each subsequent year.
 - b. Any requests for increases in prices must be supported by substantial, relevant evidence that the costs for the provision of services have increased in an amount that meets or exceeds the value of the requested increase.
 - c. The Department reserves the exclusive right to approve or deny a requested increase and to determine the amount of the increase. The Department's determination regarding price increases is final, binding on all parties, and not subject to appeal
 - d. The Department reserves the right to request price decreases at any time during the term of the Contract if it is found to be in the best interest of the Commonwealth.
 - e. Contract price increases may not exceed more than three percent per year.
 - f. Requests for increases are required to be made in writing and no later than 60 days before the annual anniversary date of the contract.
3. **LAST DATE AND TIME FOR SUBMITTING QUESTIONS:** All bid documents should be reviewed and questions prepared prior to the pre-bid meeting.
4. **PICK-UP SITE:** The Contractor must have a site within the confines of the Commonwealth of Pennsylvania for participating Local Public Procurement Units to pick up their vehicle(s), if they choose to pickup rather than have the vehicle(s) delivered.
5. **AWARD:** ALL LOTS WILL BE AWARDED ON A LOT BY LOT BASIS TO THE SINGLE RESPONSIBLE, RESPONSIVE BIDDER PROVIDING LOWEST PRICING PER EACH LOT.
6. **PRICING OPTIONS:** In order to facilitate the delivery of an In-stock or Pool vehicle in a more expedient manor than ordering a truck built to Specification or to allow for minor changes in specification to meet agency needs, the ordering unit may agree to specification changes up-to and including \$5000.00 as determined based on Dealer invoice. Changes shall be noted on the PO header or line item text and the PO shall reflect the adjusted Price. A copy of the dealer invoice with the applicable items changed, clearly marked shall accompany the vehicle at delivery.

Separate "NO LOAD" line items in each lot for CNG (Compressed Natural Gas) will not be included in the calculation for award. These items shall be factory installed or factory authorized options. If not available no response is required and in any event will not be considered in the award calculation.
7. **DELIVERY:** The contractor must deliver all units within Two-Hundred Forty (240) calendar days after receipt of a purchase order, issued against the contract. It shall be assumed by all parties that the contractor received the purchase order on the third business day following the day on the purchase order, unless the contractor provides credible evidence that the order was received on a later date.

IFB# 6100040097 Highway Support Vehicles

Delivery to be in accordance to PCID 1075 and/or PCID 1067 requirements.

8. **ADDITIONAL DELIVERY CHARGES (Participating Local Public Procurement Units ONLY):** Participating Local Public Procurement Units will pick up ordered equipment at the Contractor(s)'s place of business or have the equipment delivered by the Contractor for an additional CHARGE PER VEHICLE of \$500.00.
9. **SHIPPING:** Shall be in accordance with normal industry standards and at FOB Destination terms.
10. **MINIMUM ORDER:** The minimum order qualifying for F.O.B. Destination delivered prices shall be one (1) unit. (It is understood that prices bid & awarded are at FOB Destination delivered pricing that includes all delivery, shipping & handling, and set-up charges to the Commonwealth ordering agency's location, as stated in the Purchase Order).
11. **STANDARD WARRANTY:** The price shall include the standard manufacturer's warranty for all products provided if that warranty is greater than warranty required in the attached Terms and Conditions or PCID-1067 or PCID - 1075.
12. **Pre-Bid CONFERENCE:** Pre-Bid conference will take place on **10/04/2016 and 10:00 AM** at

DEPARTMENT OF GENERAL SERVICES
555 WALNUT STREET, 6TH FLOOR
HARRISBURG, PA 17101
CONFERENCE ROOM 1.

Public parking is no longer available in the Forum Place Garage. There is a public parking garage located across the street on 5th Street.

13. **POINT OF CONTACT AND MONTHLY REPORTS:**

Monthly Reports and other emails shall be addressed to:

Joslyn Thomas
Business Analyst
joslthomas@pa.gov

14. **INQUIRIES:**

Direct all inquiries to the following
Ralph Constance (YS4)
Department of General Services
Bureau of Procurement
Forum Place, 6th Floor
555 Walnut Street
Harrisburg, PA 17101-1914
E-Mail: rconstance@pa.gov

SPECIFICATIONS
A48-BT-A-AL

056100 thru 056500

TRUCK CHASSIS WITH 1,800 GAL FUEL TANK (MINIMUM) BODY

1,800 GAL DIESEL W/AUTO. TRANSMISSION (056100)
1,800 GAL GAS/DIESEL W/AUTO. TRANSMISSION (056500)

INDEX

I. **GENERAL TRUCK SPECIFICATIONS:**

- A. Intent Statement
- B. Weight Distribution
- C. Power-train Overview
- D. Vehicle Components
 - 1. Backup Alarm
 - 2. Axle and Suspension Front
 - 3. Axle and Suspension Rear
 - 4. Brakes
 - 5. Cab
 - 6. Chassis
 - 7. On Board Grease System
 - 8. Drive Line
 - 9. Electrical
 - 10. Engine
 - 11. Engine Accessories
 - 12. Exhaust
 - 13. Fast Lube Oil Change System (FLOCS)
 - 14. Frame and Frame Extension
 - 15. Instrumentation
 - 16. Lights - Warning
 - 17. Paint
 - 18. Safety
 - 19. Steering
 - 20. Tanks - Fuel
 - 21. Wheels/Tires
 - 22. Transmission

SPECIFICATIONS
A48-BT-A-AL

I. GENERAL TRUCK SPECIFICATIONS: (Continued)

E. Tank Body & Equipment:

1. Tank Body-Installation
2. Tank, Cabinet
3. Tank, Calibration
4. Tank, Catwalk
5. Tank, Compartments
6. Tank, Decals and Signs
7. Tank, Fenders
8. Tank Filter System
9. Tank, Fire Extinguishers
10. Tank Flashing
11. Tank Identification
12. Tank, Ladder
13. Tank Light-Warning
14. Tank, Manholes and Bottom Loading
15. Tank, Meters
16. Tank, Nozzle, Gasoline
17. Tank, Nozzle, Diesel
18. Tank, Paint
19. Tank, Piping
20. Tank, Power-Take-Offs (PTOs)
21. Tank, Pump, Gasoline
22. Tank, Pump, Diesel Fuel
23. Tank, Pump-Mounting, Gasoline & Diesel
24. Tank, Reels
25. Tank Emergency, Shut-Down System
26. Tank, Sump
27. Tank, Weight Distribution
28. Tank, Wiring and Lighting

II. DRAWINGS:

III. MANUALS:

IV. TRAINING:

V. WARRANTY:

SPECIFICATIONS
A48-BT-A-AL

I. GENERAL TRUCK SPECIFICATIONS:

A. INTENT STATEMENT:

The purpose of these specifications is to describe a vehicle for use by the Department to service road construction and maintenance equipment with gasoline and diesel fuels (codes 056500, 056700, and) or diesel fuel only (codes 056100, 056300). The vehicle shall consist of a conventional cab, dual rear wheels and rear axle drive, equipped with tank and dispensing equipment as described.

It shall be the sole responsibility of the successful vendor to ensure compatibility with the Department's trailer(s), to include not surpassing the 60 feet overall length ruling and meeting all bridge formulas. This is of particular note to those orders received for tractors without trailers. The vendor shall, prior to bid, inspect the Department's trailer(s) to ensure this compatibility. For trailer location contact the Equipment Division at 717-783-2371.

NOTE: Pennsylvania Department of General Services, PCID No. 1075, "*General Requirements for Bidding PENNDOT Vehicles/Equipment*", most current version effective at the time and date of bid opening, is included as a part of this specification. PCID No. 1075 may be reviewed and downloaded from the Department of General Services website, <http://www.dgs.state.pa.us>.

Delivery as required per Department of General Service PCID NO. 1075 Section "G". All units must be delivered within **270** days after receipt of the purchase order by the successful bidder.

B. WEIGHT DISTRIBUTION:

Weight Slip shall be provided with the pilot model for the unit supplied.

It is understood that the components specified are minimum and if the truck manufacturer's Engineering Department recommends or deems necessary, due to their particular weight distribution, a larger component or a larger GAWR totally, the burden of responsibility is hereby placed upon the Manufacturer's Engineering Department to supply a unit that is totally engineered.

1. Frame
2. Axle
3. Tires
4. Steering unit and components
5. Rims
6. Suspension
7. Brakes
8. Any other items as required

The dynamic and static loads created by the unit, plus operational stresses, must be reviewed to ensure the Commonwealth of a properly designed/engineered unit.

The vehicle shall be certified for _____LB Gross Vehicle Weight Rating (GVWR). The GVWR shall be identified in the cab or on the door as the final complete certification label (minimum rating).

SPECIFICATIONS
A48-BT-A-AL

I. GENERAL TRUCK SPECIFICATIONS: (Continued)

C. POWER TRAIN OVERVIEW:

NOTE: LUBRICANTS FOR FRONT AXLE HUBS AND DIFFERENTIALS, AUTOMATIC TRANSMISSIONS, TRANSFER CASES AND ALL REAR DIFFERENTIALS SHALL MEET OR EXCEED ALL APPROPRIATE MIL AND SAE SPECIFICATIONS FOR SYNTHETIC LUBRICANTS AND SHALL HAVE ALL PLUGS IDENTIFIED AS SYNTHETIC OR PAINTED RED.

(The OEM shall provide written exemption if synthetic oil is not installed).

ENGINE DIESEL – ENGINE- CUMMINS ISL9 MIN. 320 HP AT GOVERNED RPM, MIN, 1,000 LB/FT TORQUE. SHALL MEET LATEST EPA EMISSIONS.

TRANSMISSION – AUTOMATIC ALLISION 3500 RDS Series 6 SPEED or
3000 RDS Series 6 SPEED

Automatic transmission cooler lines shall be stainless steel or a **preapproved** no-rusting material.

REAR AXLE – 23,000 LB. Min. DANA, Meritor or Mack in accordance with the specification.

NOTE: All rear axles must provide axle shafts with a minimum diameter of 2.19 inch at the spline.

NOTE: REAR AXLE/S SHALL HAVE AN EXTENDED BREATHER TUBE TO PREVENT DEBRIS BUILDUP.

SPECIFICATIONS
A48-BT-A-AL

I. GENERAL TRUCK SPECIFICATIONS: (Continued)

D. VEHICLE COMPONENTS:

1. ALARM - BACKUP:

Ecco model 450 (rubber mounted) Installed.

2. AXLE AND SUSPENSION FRONT:

16,000 LB capacity, minimum.

Front spring rating shall be equal or greater than the axle rating supplied.

The front axle, drag links and tie rods shall have grease zerks installed.

Sufficient tire clearance at maximum turning angles.

Complete "STEMCO" oil seal assembly, including hub, plug type window and "GUARDIAN" seal, or approved equal.

Each unit shall have the front end aligned.

The front axle king pin bushings shall be the bronze type.

The king pins shall be manufactured to produce even flow of grease to all vital front end areas of the knuckle assembly.

The pin or bushing shall be grooved to permit grease flow.

Setback front axle is unacceptable. Setback axle constitutes anything with a measurement from bumper-to-axle (before frame extension) "BA", not to exceed 37 inch.

3. AXLE AND SUSPENSION REAR:

Rear spring rating shall be equal or greater than the axle rating supplied.

See Power Train Overview for acceptable axle.

STEMCO GUARDIAN rear wheel seals, or approved equal.

Magnetic drain plug.

Torque-proportioning traction-assist device or a traction device is required. The device shall provide maximum traction to rear wheels when actuated. The traction-assist device shall be driver actuated by a dash mounted traction control switch.

ALUMINUM OR LIGHTWEIGHT HOUSING IS NOT ACCEPTABLE.

NOTE: Rear axle ratio selection will be made after the award and may be a mix of ratios as required. The successful vendor/manufacturer shall present three (3) computer runs showing the three (3) most likely ratios for consideration for a speed range of 55 MPH to 65 MPH max. This information shall be presented at the pre-build meeting.

SPECIFICATIONS
A48-BT-A-AL

I. GENERAL TRUCK SPECIFICATIONS: (Continued)

D. VEHICLE COMPONENTS: (Continued)

4. BRAKES:

Braking System: Full air in compliance with the most current FMVSS requirements.

The ABS shall incorporate a diagnostic fault switch that is capable of illuminating a fault light for diagnostic purposes. The switch shall be easily accessible and can be either dash or under-dash mounted. A dash-mounted display that will show all SAE message descriptions for the ABS is an acceptable means of diagnostics in lieu of the fault switch.

Rear brakes: 16.5 inch x 7 inch "S" cam with quick change type single or double pin. (No substitute - standardization).

Drum brakes shall have automatic slack adjusters and they shall be clearance sensing type only, and they shall be clearance sensing with adjustment on application of the brake (no substitute).

Steer axle brake: 16.5 inch x 5 inch or 16.5 inch in x 6 inch, "S" cam or a power front disc brake system providing equal performance. Quick change type single or double anchor pin if drum type brakes are furnished.

Backing plates on all drum brakes.

Air compressor: Manufacturers Standard

Buzzer-type, low air pressure indicator. Compressor shall be fitted with a safety valve to prevent mechanical failure.

Parking brake: Rear wheels, spring-type, MGM 30/30 or ANCHORLOCK 30/30 gold seal chambers (no substitute). Parking brake shall provide modulated emergency braking via the foot valve in the event of a rear service system failure.

Air tank: Automatic drain valve, with heater on wet (first) tank. Each of the remaining air tanks shall have a manual drain valve.

Air dryer: With heater, mounted away from road splashing and a minimum of 20 inches above road surface. Dryer shall be compatible with the body company clearance requirements for sub-frame, valve body, etc. Per: Haldex DRYest or Bendix AD-IP installation made in concurrence with the air compressor manufacturer's recommendations.

Air dryer shall be placed to accommodate the changing of filter cartridges without disconnecting any hoses or removing dryer base from its mounting location. Final mounting location shall be determined at Pre Build meeting. All electrical connectors for drain valve and air dryer shall be covered with heat shrink material or have sealed connections.

Brake valve shall be mounted away from road splashing.

System shall be equipped with anti-compounding to prevent mechanical failure of the foundation brakes, slack adjusters, etc.

SPECIFICATIONS
A48-BT-A-AL

I. GENERAL TRUCK SPECIFICATIONS: (Continued)

D. VEHICLE COMPONENTS: (Continued)

5. CAB:

Aluminum or steel cab.

Hood: Fiberglass, tilting. Fenders are part of tilting hood.

Fenders: Front fenders shall have extensions to cover the width of the front tires.

Air deflector: Clear or smoke, hood mounted. Deflector manufacturer's standard width for the truck model. Access to front end hood tilt handle shall not be blocked. Extra handle acceptable. Ref. DEFLECT-SHIELD Corp., Tele. 1-800-247-2440.

Seats: Driver's seat shall be high back adjustable BOSTROM Air 915 Series with lumbar support or National 2000 Series with lumbar support or DuraForm Air Command Series (fabri form cushions with lumbar support) with body cloth insert and three-point retractable seat belt. **(Seatbelt shall be High Visibility Orange)**. A bellow-type or protective skirt shall cover the seat suspension mechanism. There shall be an inside arm rest on the drivers seat. No substitute on seats reference. Color coordinated to cab interior.

Passenger seat: With three-point retractable seat belt. **(Seatbelt shall be High Visibility Orange)** manufacturers standard non-suspension (static), high back type. Color coordinated.

Note: If due to cab configuration a Bostrom 915 seat cannot be used, a Bostrom 910 may be substituted. All other requirements must be met.

Deluxe fresh air hot water heater, manufacturer's highest output.

Safety glass throughout.

Windshield: One (1) or two (2) piece construction, tinted.

Dual sun visors.

Cruise Control

Dual windshield defrosters.

Drivers and passenger side windows shall be power.

Dual windshield wipers: Arctic wipers and heaviest, motor, arms and linkages available. Wiper blades, maximum length, shall follow windshield contours. They shall be minimum two (2) speed intermittent.

Washer system shall be electric. Washer tank shall be a minimum capacity of two (2) quarts of washer fluid. It shall be filled with an anti-freeze type solvent.

Mirrors: Drivers and passengers side power mirrors, west coast style minimum 7 inch X 14 inch manufacturers standard heavy-duty breakaway arms.

Mirrors shall be heated with a lighted toggle switch mounted within accessible reach of the operator, automatic on/off is acceptable. The wires shall be fitted in such a way that the mirror glass/element can be changed by unplugging the two-wire lead. There shall be a heated convex mirror both sides, minimum 6 inch X 7 inch or 8 inch diameter, minimum.

A heated blind-spot elimination mirror shall be mounted on the right front fender and it shall be minimum 7 inch X 7 inch or 8-inch diameter, stainless steel or aluminum head with mirror. Mirror shall be a conventional convex mirror, and shall not be of the half-round cross view type. All arm/s and hardware shall also be stainless steel. Fender type washers stainless, or aluminum, with rubber pads to be placed on both sides of the fender shall be included.

Pedestal system shall be single, double or triple mounting assemblies (stainless steel or aluminum). Mirror shall be mounted in rubber or vinyl. Ref: Grote (800-628-0809).

SPECIFICATIONS
A48-BT-A-AL

I. GENERAL TRUCK SPECIFICATIONS: (Continued)

D. VEHICLE COMPONENTS: (Continued)

5. CAB: (Continued)

Drivers and Passenger entrance steps: Shall be aluminum, Bustin No NST4 full size or Ohio Grating No. JA2119SG4 serrated or IKG Industries Type BS4 serrated swage lock, with end band. The size and strength shall be in accordance with the truck manufacturer's step design but the material shall be as noted above. The outer step edge must be serrated in lieu of plain, smooth metal edge. All edges shall be banded (skirting) on the outer perimeter. Overlay not acceptable. Top of the first step shall be at a maximum of 22 inch above the ground. Step design material must be the same design and material on the left and right sides.

Grab handles shall be supplied on all cab entry locations. Three points of contact shall be achievable at all cab entry locations. Handrails shall be coated with non-skid paint (non-skid tape is unacceptable) or have OEM anti-slip rubber inserts, both non-skid paint or rubber inserts must extend the full length of the grab handle.

Exterior grab handles shall be supplied if available from OEM.

There shall be a permanent decal, "Three Point Contact" located at each entry point of the truck cab and at tank ladder area per EQN – 552-1. Exact location to be determined at pre build meeting.

There shall be a permanent decal, 2 inch high red letters on white back ground affixed by the driver side door handle stating the overall maximum travel height of the completed and unloaded unit. (Example) HT-__' __" Ref. EQN-552.

Air horn(s): Minimum 1 horn with snow-shield (not required if under hood mount).

All controls and knobs shall be properly identified.

The cab floor covering shall be heavy duty rubber with closed cell rubber or heavy felt backing.

The engine components facing wheel areas, on both sides, and the areas to the rear of wheels shall be shielded.

Inside dome light shall be provided.

Emergency triangle warning kit, with hold down. Warning Triangle Flare Kit, Ref: KD Lamp Co. or equal, stowed (fastened) in the cab, per EQN-66A

One (1) pair of CB Power connections, at the dash, per EQN-78.

Air conditioning: Highest output available as OEM option.

Cab shall have an air suspension system.

Steering wheel diameter shall be 18 inch (approx.). Manufactures standard.

Steering Column: Steering wheel and column shall be tilt and telescopic, infinitely adjustable to multiple positions.

AM/FM radio with Weather Band.

Cup Holder: There shall be a cup holder in the cab within easy reach of the operator.

SPECIFICATIONS
A48-BT-A-AL

I. GENERAL TRUCK SPECIFICATIONS: (Continued)

D. VEHICLE COMPONENTS: (Continued)

6. CHASSIS:

Cab Axle (CA) dimension: Wheel base and CA dimension may be adjusted to provide the optimum legal weight distribution.

Axle-frame (AF) dimension: Shall incorporate a cross member at the rear of the frame.

Front Bumper: Mounted to the frame with the inner face of the bumper against the chassis frame.

Front mounted tow hooks or eyes: Two (2) front or one center mount tow pin. May be installed by the body company using grade 8-bolts (minimum) of sufficient strength and length, and self-locking nuts, or by full welding.

License plate bracket: Front and rear.

7. ON BOARD GREASER SYSTEM

There shall be a centralized on board chassis lubrication system installed. Ref: EQN-501.

8. DRIVE LINE:

Main driveline: Spicer Life XL or Meritor MXL Series. "**Factory balanced**" greasable, (one zerk minimum). Heavy-duty driveline shall be engineered and be compatible to engine, drive train and transmission torque. Heavy-duty center bearing, if required, with due consideration to drive shaft angles, length, location, proper bolting based upon engine and transmission selection. Inter-axle driveline: Spicer Life XL or Meritor MXL Series.

9. ELECTRICAL:

All copper system, negative ground.

Batteries: Three (3) heavy-duty, 12-volt, field maintenance-free, BCI Group Size 31, with stud-type posts and anti-corrosion treatment on each terminal. Amperes (CCA) 2500 at 0 degrees F.

Battery Mounting: It shall include the following:

- a) 0.25 inch thick rubber shock pad under the battery.
- b) Box with cover. Cover shall be constructed of fiberglass, poly, or aluminum, (if aluminum there shall be an insulating liner).
- c) Mounting bolts grade-8 with self-locking nuts.

Mounting of accessories within the battery box is prohibited.

Cables shall conform to RCC Practice 105 with "sealed" terminal ends for stud-type battery posts.

Electrical system: Circuit-breaker-equipped, in easily accessible location, weatherproof. Fuses acceptable in circuit so identified by manufacturer as safety factor. Any fuse or circuit-breaker liable to be damaged during truck operation shall have an easily removable protective cover.

All wire splices in the cab shall be heat shrink material. Ref: THOMAS & BETTS, Tel: (201) 707-2145.

Alternator: Delco 36SI (No substitute, Standardization) 160 A minimum, high performance, solid state (brushless).

SPECIFICATIONS
A48-BT-A-AL

I. GENERAL TRUCK SPECIFICATIONS: (Continued)

D. VEHICLE COMPONENTS: (Continued)

9. ELECTRICAL: (Continued)

Starter motor: Delco 39 MT (No Substitute, Standardization) with thermal over-crank protection and high torque capacity. Suitable for the diesel engines offered as per starter manufacturer's recommendation.

Note: Starter shall have (OCP) either built in or controlled by the Vehicle's control system, (if required).

Alternator and starter mounting bolts: Grade 8.

Flasher: (All) heavy-duty electrical, Ref: Tridon Model EL 12 or equal.

Note: If an audible alarm is supplied for 4 ways and turn signals, it shall have an on/off capability. All exposed junctions: Waterproof and sealed against salt.

GPS Combo Radio Antenna: There shall be a roof mount base with built-in GPS, PCTEL model GPPB-204-54-12-S1-M1 and a low profile black antenna, PCTEL model BMLPU700.

Assembly shall be mounted on pedestal (installed with mini light bar) REF. EQN 120Q, with the antenna cable routed to the floor area between the seats. There shall be a minimum of 4 feet of antenna cable coiled at the base of the floor to allow for connection of department state radio. Antenna shall be prewired with a MINI - UHF MALE connection. **(No substitute, standardization).**

Power Distribution Center: There shall be a 4-way power/ground distribution center located on the underside of the dash for connection of department state radio. The lugs shall be configured in the following manner: (1) lug shall be a 30 ampere constant hot circuit, (1) lug shall be a 10 ampere ignition controlled circuit. (2) lugs shall be chassis ground. All connections shall be enclosed in a weatherproof enclosure.

10. ENGINE:

See POWER TRAIN OVERVIEW for acceptable engines.

Replaceable heavy-duty full flow type fuel filter(s) and oil filter(s) as recommended by the manufacturer, bearing a legible OEM part number.

Cooling system: The largest factory available capacity compatible with engines and transmissions referenced. With overflow recovery system and visual level indicator.

Radiator core and shell: Shall be manufacturer's heaviest construction grade radiator available. Radiator with a "cut-out" to accommodate PTO shaft will not be accepted.

The cooling system shall be fitted with provisions for visually monitoring coolant without necessitating removal of the cap from the radiator or expansion tank (e.g. sight glass, transparent expansion tank).

The oil dipstick must have tubing and dipstick with sufficient length to provide reasonable access.

SPECIFICATIONS
A48-BT-A-AL

I. GENERAL TRUCK SPECIFICATIONS: (Continued)

D. VEHICLE COMPONENTS: (Continued)

11. ENGINE ACCESSORIES:

Automatic idle shutdown shall be set to five (5) minutes. An audible warning alarm shall be provided to alert operator prior to engine shutting down. Automatic idle shutdown shall be programmed to be overridden when the PTO Mode is engaged.

ECM shall be set to a maximum of sixty five (65) miles per hour.

Engine Heater: Immersion in-block type, for cooling system, with waterproof plug flush-mounted in an accessible location at the front/roadside of the vehicle, outside the cab/hood, 110 volt, 3-prong plug. The electrical cable from the heater to plug shall be one piece and waterproof.

Coolant/filter: A non-charged spin-on coolant filter shall be installed if required by engine manufacturer.

Air Cleaner: Air cleaner shall be the manufacturer's heaviest duty air cleaner that meets of the extended engine warranty.

Fan: Thermostatically controlled, viscous type or manufacturer's recommended automatic fan.

Screening system: Mounted in front of radiator grille that protects radiator from stones and bugs.

System to be approved by engine and truck manufacturer(s).

Diesel Fuel Filter: There shall be a DAVCO 382 or a 482 filtration unit installed and mounted (Higher than fuel tank) per manufactures recommendations in a location to accommodate filter replacements, yet be protected from road debris(**No substitute, standardization**). Mounting location to be determined at pre-build meeting.

Davco 382 Unit shall be equipped with engine coolant heat and 120 volt heater circuit. The 120 volt circuit and engine block heater shall be powered via the same electrical connection. (**No substitute, standardization**)

Davco 482 shall be equipped with a 12 volt and 120 volt heater circuit. 12 volt heater circuit will activate with the ignition key switch, the 120 volt heater circuit and engine block heater shall be powered via the same electrical connection. (**No substitute, standardization**)

Air restriction gauge: Flush, dash-mounted with indicator slide for engine air cleaner, RE: FILTER MINDER, manufactured by Engineered Products Company. If the vehicle is OEM equipped with an electronic dash that incorporates an air restriction gauge or indicator light, shall be acceptable.

Governor: Set at manufacturer's recommended maximum engine speed (rpm).

Hoses: The air induction system and large cooling system hoses shall be clamped with 0.500 inch wide, 150 inch LB stainless steel, constant torque, spring loaded worm clamps. RE: WITTEK Manufacturing or BREEZE Clamp Co, constant torque clamps with liner for silicone hoses. Cooling system hose under 1 inch OD may use factory standard hose clamps as a minimum acceptable standard.

Air intake hoses shall be 0.25 inch minimum thickness, molded hoses. RE: GATES, GOODYEAR or equal.

Lubricating oil lines: If hoses are used, they shall be wire braid type, "AEROQUIP" or approved equal system, minimum standard.

OPTION: Engine shall be equipped with a minimum 2 stage, full engine compression brake, Brake lights shall activate when engine brake is activated Ref: Jacobs.

SPECIFICATIONS
A48-BT-A-AL

I. GENERAL TRUCK SPECIFICATIONS: (Continued)

D. VEHICLE COMPONENTS: (Continued)

12. EXHAUST:

DPF (diesel particulate filter) and exhaust system shall meet the latest EPA emission requirements. Vertical tailpipe with elbow and muffler system or horizontal muffler and vertical tail pipe elbow. Exhaust system shall neither interfere with body nor will it be close to any fluid tank. The muffler, tail pipe and DPF shall be shielded or insulated to protect personnel from burns when entering or exiting the cab. The shield shall be 180 degrees. RE: RIKER or equal.

13. FAST LUBE OIL CHANGE SYSTEM (FLOCS):

This FLOCS system shall be installed with all fittings, brackets, clamps and hoses. Hose from oil pan to FLOCS fitting shall be hydraulic hose with a 100R2 rating and properly secured. The system shall be compatible with all fittings presently used by the Department. The final placement of the male half of the snap coupler, on the equipment, shall be determined at the pre-build meeting. Ref: EQN-351A.

14. FRAME:

Resisting Bending Moment (RBM): Minimum of 1,600,000 inch LB per rail, for the entire length of the frame. Minimum frame RBM shall be approved by manufacturer's Engineering Department. Frame material: Heat treated carbon steel, at least 110,000 PSI yield strength. Main frame: Either straight channel or offset channel, full length. Drop frames are not acceptable.

15. INSTRUMENTATION:

All instruments illuminated and dash-mounted except where specified otherwise. All standard instruments shall be supplied, including, but not limited to the following:

Gauges:

Oil pressure: with warning light or audible alarm.

Air pressure: gauge(s) for dual circuit, dual indicator with low pressure audible alarm.

Coolant temperature: with warning light or audible alarm.

Transmission oil temperature: for automatic transmission only, with warning light or audible alarm.

Fuel gauge.

Hour meter that records only when the engine is running. In-dash, integral with instrument panel (e.g., speedometer) is acceptable. Ref: DATCON or equal. Hour meter shall be illuminated and shall be readable from the operator's seat.

Speedometer with odometer.

Tachometer.

Voltmeter.

Parking brake indicator light.

SPECIFICATIONS
A48-BT-A-AL

I. GENERAL TRUCK SPECIFICATIONS: (Continued)

D. VEHICLE COMPONENTS: (Continued)

16. LIGHTS - WARNING:

Head lights Ref: Halogen. Separate switch.

Headlights shall meet NHTSA requirements of "Daytime Running Lights" (DRL). DRL's shall be OEM optional equipment or after market.

All cab and body lighting shall be LED if available.

Parking lights front and rear, stop, turn, tail lights, back-up lights and license plate light with light bracket.

Hazard lights separate switch.

Body lights shall have their own dedicated complete circuit.

2- Whelen R10PADOT Light Bars to be pedestal mounted 1 to front of tank (with antenna mount) and 1 to rear of tank. In no case shall the light bar be mounted on the roof of the vehicle.

Light bars wired together shall have a lighted, permanently labeled toggle switch (1) located in the dash.

Body wiring shall be Grote, Trucklite, or Prior Approved Equal.

There shall be no splices outside of a sealed box or fixture.

A color-coded electrical wiring chart and schematic shall accompany each body.

Electrical chassis-wiring harness: Body lighting and wiring to be per EQN-80XF.

Flasher: (All) heavy-duty electrical, Ref: TRIDON Model EL12.

Note: If an audible alarm is supplied for 4 ways and turn signals, it shall have on/off capability.

Hazard lights, stop and tail lights, back-up lights.

All exposed junctions: Waterproof and sealed against salt.

17. PAINT:

Cab shall be painted PennDOT yellow Ref: DuPont F9885, PPG 85246, Sherwin Williams 73266, Sikkens 4017 or NAPA 73266 for shade only. Frame and all underside components shall be painted black. Front bumper and plow frame shall be primed and painted black (with hardener) low VOC. All bare metal surfaces shall be coated using etching primer prior to paint. All surfaces shall be properly cleaned and prepared prior to paint, with all weld splatter and debris removed.

Running boards shall be primed and painted black or yellow.

Front bumper shall be painted black, argent or chrome.

Cab and body shall have reflective enhancement per EQN-127A.

18. SAFETY:

All areas likely to be stepped/climbed/walked upon, including steps, shall be furnished with Bustin No. NST4 full size or Ohio Grating No. JA2119SG4 serrated or IKG Industries Type BS4 serrated swage lock, with end band.

Anti-slip paint is required on all handholds, for the entire length, (tape is unacceptable). All handrails, ladders, and step configurations shall be built for three points of contact.

The above details shall be reviewed at the pre-build meeting with the successful vendor, and further verified as to the manufacturer's compliance at the actual pilot model inspection.

Fire extinguisher: Rechargeable with vehicle mount. Mounted in the cab for easy and quick access.

Ref: 3A:40B:C. 5lb.

SPECIFICATIONS
A48-BT-A-AL

I. GENERAL TRUCK SPECIFICATIONS: (Continued)

D. VEHICLE COMPONENTS: (Continued)

18. SAFETY: (Continued)

There shall be wheel chocks and holders per EQN-82. Chocks (2) shall be mounted together on the left side of vehicle. (Exact location shall be determined at the pre-build meeting)

All corners shall be angled or rounded for safety.

The vehicle shall meet all the requirements set forth in EQN-118.

19. STEERING:

Power steering: Dual integral or single integral type hydraulic with right wheel power assist cylinder. With stops to prevent damage to system.

Glidecoat steering shaft, Bendix wedge lock lube-for-life shaft, ZF type steering shaft.

Steering system: (e.g. flow, pressure, relief valve etc.) Shall be selected considering the full front axle loading. Ref: ROSS, SHEPPARD or TRW gear assembly (No substitute, standardization.)

Hydraulic supply pump: Vane type or roller type with one (1) steering wheel revolution per second capacity in a "park" condition. BORG WARNER.

The pump shall not be the integral filter type unit.

Power Steering Reservoir: "Remote mounted", and factory mounted, minimum two (2) quart capacity, incorporating a filter which is easy to remove and replace.

The remote filter referenced above shall be certified and engineering approved in conjunction with the appropriate pump.

20. TANK - FUEL:

Safety-type fuel tanks as per the requirements of FMVSS.

80 GAL minimum total capacity, frame mounted, under the left door.

Aluminum or stainless steel, unpainted.

Heavy duty mounting straps with rubber shims/liners.

Tank mounting hardware and brackets shall be for "severe duty" applications, 2 inch wide heavy duty aluminum or stainless steel straps and gaskets.

Accessible fill located at either end of tank to avoid interference with steps.

Dual tanks are unacceptable.

21. WHEELS/TIRES:

The truck shall be equipped with hub piloted steel disc wheels for tubeless tires. The wheel end shall be equipped with outboard cast brake drums, and 15 degree tubeless steel wheels, hub piloted, 10 hole - 285.75mm bolt circle with 22mm two-piece flange nuts.

Front: Wheels: 22.5 x 9.00, 10 hole - 285.75mm bolt circle with 220mm bore, tubeless steel disc wheel rated at 10,000 LBS at a maximum inflation pressure of 120 PSIG. Accuride part number 29039. **(No substitute, standardization).**

Rear: Wheels: 22.5 x 8.25, 10 hole - 285.75mm bolt circle with 220mm bore, tubeless steel disc wheel rated at 7,500 LBS at a maximum inflation pressure of 120 PSIG. Accuride part number 28828 or 29169. **(No substitute, standardization).**

SPECIFICATIONS
A48-BT-A-AL

I. GENERAL TRUCK SPECIFICATIONS: (Continued)

D. VEHICLE COMPONENTS: (Continued)

21. WHEELS/TIRES: (Continued)

The dual rear wheel/tire assembly shall have clearance between the tires, which permits the use of dual tire chains.

Wheel-Guard Separators: The wheel ends shall be equipped with the Accuride part number 5903 Wheel Guard Separator as follows:

Front axle - between the wheel and the brake drum.

Rear axle - between the inner dual and the brake drum and between the inner and outer duals.

Paint: The wheels shall be topcoat painted with TGIC Polyester Powder Paint MLD-82008 High Gloss Gray or equal applied over Cathodic Electro-Disposition Gray Primer.

Tires: All tires shall be radials.

Front Tires: 315/80R22.5 (Load Range L).

Rear Tires: 12R22.5 (Load Range H).

MANUFACTURER

Goodyear

Michelin

Bridgestone

FRONT TIRE

G-289

XZY3

M843

REAR TIRE

G-282 MSD / G-622 RSD

XDN-2

L320

22. TRANSMISSION: See POWER TRAIN OVERVIEW for acceptable transmission.

Oil cooler for transmission required due to prolonged transmission torque converter operation in low gears. Cooler size must be provided to keep the transmission fluid at an acceptable operating temperature under these prolonged conditions. (Water-to-oil type cooler.) An Allison approved cooling system shall be installed regardless of whether retarder is incorporated in the system or not. Automatic transmission cooler lines shall be stainless steel or a preapproved no-rusting material.

Automatic transmission cooler lines shall be stainless steel or a preapproved no-rusting material.

NOTE: All vehicles shall have a transmission-operated safety starting switch.

SPECIFICATIONS
A48-BT-A-AL

I. GENERAL TRUCK SPECIFICATIONS: (Continued)

E. TANK BODY & EQUIPMENT: (EQN-88, 352, 352A AND 352B)

1. TANK-BODY-INSTALLATION:

It shall be the responsibility of the successful vendor to have this fuel tank mounted on the specified chassis. The installation shall be engineered and approved by the vehicle and tank manufacturer and shall have no adverse effect upon either manufacturer's warranty. When any portion of the complete vehicle is to be installed by anybody other than the bidder or chassis manufacturer, the bidder shall indicate in the bid proposal the name of sub-contractor(s) performing such installation and the location of their plants, and submit a detailed tank and equipment specification as well as air and electric wiring schematics.

2. TANK, CABINET:

Rear:

Continuous-type hinges, of AISI Type 304, non-magnetic stainless steel.
Watertight doors with gaskets.
Recessed door lock fitted with key-operated cylinder lock, with 2 keys (keyed alike).
Single, vertical, hinged doors.
Light(s) to illuminate cabinet, with on-off switch wired to running lights.
Two (2) louvered vents on front and rear of the cabinet top.

Auxiliary Fluid Tank: RH OR LH SIDE

Continuous-type hinge, of AISI Type 304, non-magnetic stainless steel. Ref: EQN-89 (dimensions may be altered to allow for proper fit, clearance, and to meet all safety requirements.

LH, RH, OR REAR:

There shall be a cabinet with a "New Pig" spill kit 233J (61 LBS) or equal.

NOTE: All cabinets shall be keyed alike (2 keys per lock).

3. TANK CALIBRATION:

The tank manufacturer shall furnish two (2) charts for each unit showing the fuel content in gallons relative to the depth of fuel in inches. (Only 1 if diesel fuel only.)

4. TANK, CATWALK:

Anti-slip paint is required on all handholds, for the entire length, (tape is unacceptable). All handrails, ladders, and step configurations shall be built for three points of contact.
EQN-352B. There shall be a permanent decal, "Three Point Contact" located at the entry point of the tank ladder per EQN – 552-1. Exact location to be determined at pre build meeting.

SPECIFICATIONS
A48-BT-A-AL

I. GENERAL TRUCK SPECIFICATIONS: (Continued)

E. TANK & BODY EQUIPMENT: (Continued)

5. TANK-COMPARTMENTS:

The cargo tank shall be the latest design and construction MC qualified in accordance with the requirements of 49 CFR 178.341.

Two (2) compartments, 200 GAL (under no circumstances shall it exceed 300 GAL) for gasoline and 1,600 GAL minimum for diesel fuel (mounted against truck cab) separated by a double bulkhead. For single product tank minimum acceptable is 1,800 GAL. Flanged and dished surge baffles, 6 inch to 8 inch concave, shall be installed in each compartment to provide a complete internal splash baffling system. Double bulkhead with 0.5 inch threaded openings at top and bottom of double bulkhead to immediately alert the operator of a bulkhead leak. The top opening is to be plugged.

The tank size shall be increased to provide the maximum payload possible without exceeding the axle laws.

Smooth skin type. Flanged, dished, 0.190 inch side shell, 0.160 inch bottom, 0.250 inch Minimum thickness.

The bottom of the tank mounting rail shall be a 0.313 inch minimum. The mounting rails shall be aluminum extrusion(s).

There shall be a fold-up manual dip stick.

6. TANK, DECALS AND SIGNS:

The placard holders must be provided in accordance with the provisions of 49CFR 172.516 and Appendix C. The front and rear of the truck shall have signs mounted where appropriate.

The tank shall have hazardous material warning decals on both sides.

Heavy duty, full width, 8 inch steel channel type rear bumper securely attached to chassis frame rails.

Any alternate design shall be pre-approved, in writing from Chief, Equipment Division.

The entire rear of the tank cabinet door and both sides shall have tape applied per EQN-80XF.

Decals showing the grounding procedures for both reels shall be furnished and placed in the canopy area within view of the operator.

All required decals and signs for the fuel tank shall be as per the regulations and shall be furnished and installed by the successful vendor.

Compartments containing hazardous materials spill supplies shall be labeled.

There shall be "No Smoking" decals posted on each side of the tank.

SPECIFICATIONS
A48-BT-A-AL

I. GENERAL TRUCK SPECIFICATIONS: (Continued)

E. TANK & BODY EQUIPMENT: (Continued)

7. TANK, FENDERS:

Jeep type.

0.125 inch (minimum) aluminum.

Fold and hem inside-and outside edges.

Brackets shall be welded to box sill of tank.

Bolted fenders, removable type, and aluminum.

18 inch mud flaps. (Front fenders).

As required mud flaps. (Rear of fenders to meet MV Code).

Rear mud flaps: 6 inch off ground level, as per EQN-66.

8. TANK FILTER SYSTEM:

The tank pumps and meters shall be protected by means of four (4) strainers to eliminate foreign material entry. Each strainer shall be easily accessible for cleaning. (Only 2 if diesel fuel only.)

9. TANK, FIRE EXTINGUISHERS:

Two (2) rechargeable 10 LB dry chemical 20-B, C rated fire extinguishers with charge condition indicator and red water-proof snap on covers. Extinguishers shall be mounted per regulations. Shall be in compliance with NFPA Standard No. 385 - Chapter 6-3 and NFPA Standard No. 10 and General Regulations governing the Highway Transportation of Hazardous Substances and Federal Motor Carrier Safety Regulations, Title 49, Item 393.95, Item A, 2 (I).

10. TANK FLASHING:

Extruded vapor tight turret rails.

Aluminum grating between manholes, flush to flashing.

Two (2) 2 inch drains at rear of flashing.

Aluminum round stock hand rails shall extend the entire length of the turret.

EQN-352A and EQN-352B.

11. TANK IDENTIFICATION:

The date of tank manufacture shall be posted.

The tank shall be identified with the information on gasoline and diesel fuels on both sides of the tank flashing. The manholes on top of the tank shall be identified as to tank content. The gallon-capacity shall also be shown. Tank concurrence with Federal requirements shall be posted.

SPECIFICATIONS
A48-BT-A-AL

I. GENERAL TRUCK SPECIFICATIONS: (Continued)

E. TANK BODY & EQUIPMENT: (Continued)

12. TANK, LADDER:

Full length, 16 inch wide with 12 inch step increments.

Located on left side.

First step height maximum 24 inch above ground level.

1.875 inch to 2.5 inch wide serrated and self-cleaning aluminum step material as manufactured by BUSTIN Industrial Products, Inc., Ohio Grating or IKG Industries Inc.

A safety decal shall be furnished and installed at the ladder location.

1.625 inch approximate OD tubular hand rails with BUSTIN type step material. Ladder reinforcements shall be dual and sturdy in design.

All grab handles shall be provided with anti-slip friction paint. Anti-skid tape is unacceptable. EQN-352A.

13. TANK LIGHT-WARNING:

See I.D.16.

14. TANK, MANHOLES AND BOTTOM LOADING:

Each compartment to consist of the following:

Betts vapor recovery manhole assembly.

EBW (air operated) 3.50 inch air operated vent with vapor recovery hood to be connected to vapor light curbside overturn rail.

Standard Bottom Loading adapter with cap, chain and API air operated interlock.

Probe sensor and holder.

(1) 3 inch aluminum rear vapor line with 4 inch x 3 inch adapter, dust cap and API air operated interlock.

(1) API air operated interlock to be installed on compartment operator.

(1) EBW starship module.

(1) EBW starflex -2 O.T.A. receptacle module for optic thermistor.

Receptacles to be capable for all terminals.

Internal deflector, internal static cable.

Grounding bolt.

System shall include, at a minimum, everything for a complete Bottom Loading/Vapor Recovery "Go Anywhere System".

SPECIFICATIONS
A48-BT-A-AL

I. GENERAL TRUCK SPECIFICATIONS: (Continued)

E. TANK BODY & EQUIPMENT: (Continued)

15. TANK, METERS:

Two (2) (1 if only diesel fuel) "LIQUID CONTROLS" Model M-5-G-2; 1.50 inch meter with register 10:1 "LIQUID CONTROLS" electronic pulsar, Model A. 42675.

Each meter shall be equipped with reset-able ticket printer, Zero (0)-start, counter to accurately record all deliveries and pre-determined counter to indicate amount of fuel remaining in tank. Ticket printer shall be designed to accommodate tickets currently in use by the Department.

Rated from 5 GPM/19 LPM to 60 GPM/227 LPM with 150 PSI maximum working pressure.

Mounted in rear bucket box, one connected to each pump.

Ref: EQN-352.

2 inch gate valve between each meter and hose.

Air eliminator, strainer shall be furnished.

Meters shall be furnished with 40-mesh strainer for diesel fuel and 80-mesh strainer for gasoline.

Each meter shall have an exterior light to illuminate meter dials; to be wired into running lights with on-off switch.

Air eliminator lines shall be piped to product compartment in accordance with manufacturer's specifications.

1.250 inch diesel, 1 inch gas solenoid valve (if applicable) 12 V dc of proper size in each fuel line. Ref: ITT General Control or equal in each fuel line.

16. TANK, NOZZLE, and GASOLINE: (If Applicable)

Nozzle shall be of adequate size to fit unleaded gasoline tank fill pipes and to perform safely within the velocity created by 15 GPM/57 LPM flow rate.

Nozzle shall be equipped with swivel and check valve with automatic shut-off features.

The nozzle shall be OPW-11-AP with D-907M insulators and OPW No. 285 or No. 33, 1 inch swivel. A holder to accommodate this nozzle shall be provided by tank supplier and shall be open to let excess fuel drippings drain to the ground. New units only (rebuilt units are not acceptable). Phone (513) 870-3219 for nozzle manufacturer.

17. TANK, NOZZLE, DIESEL:

Nozzle shall be of adequate size to perform safely within the velocity created by 35 GPM/132 LPM flow rate.

Nozzle shall be equipped with swivel and check valve with automatic shut-off feature.

The nozzle shall be OPW 7H-5400 and OPW No. 285 or No. 33, 1 in/254cm swivel. A holder to accommodate this nozzle shall be provided by tank supplier and shall be open to let excess fuel drippings drain to the ground. New units only (rebuilt units are not acceptable). Phone (513) 870-3219 for nozzle manufacturer.

18. TANK, PAINT:

Not applicable. Tank, fenders, cabinet, cat walks and ladders shall be aluminum. Tank, fenders, and cabinets shall be polished and sealed. Conspicuity tape per EQN-80XF.

SPECIFICATIONS
A48-BT-A-AL

I. GENERAL TRUCK SPECIFICATIONS: (Continued)

E. TANK BODY & EQUIPMENT: (Continued)

19. TANK, PIPING:

All welded tubing with flexible coupling to relieve line strain; a minimum of five (5) flexible couplings per pump/meter system.

Pump discharge lines to be supported at two (2) locations between pump discharge and bucket box location. REF: VICTAULIC, grooved, cast type coupling.

20. TANK, POWER-TAKE-OFFS (PTO's):

Chelsea Series 221 or 270.

Two (2) heavy-duty, tubular drive-shafts with lubrication fittings.

Controls located in rear compartment with lighted indicators (including chassis cab) to alert operator that pumps are engaged. REF: Air-operated CHELSEA 221ZCAHX-A-3XD or 270RCAJPB5XD (Hot Shift).

PTO/Wheel brake interlock. REF: BENDIX-WESTINGHOUSE inversion valve no. 277340 (no substitute).

21. TANK, PUMP, GASOLINE (CODE 056500 ONLY):

One (1) BLACKMER Model TXD-2 pump.

2 inch line strainer on suction side, one 0.0625 inch perforation screen.

12 to 15 GPM/45 to 57 LPM rate of flow.

Flow divider capable of maintaining 12 to 15 GPM flow to the nozzle.

Flow divider to return excess fuel to suction side of the pump to be installed with flexible couplings.

REF: BLACKMER Differential bypass valve BV2 or prior-approved equal.

22. TANK, PUMP, DIESEL FUEL:

One (1) BLACKMMR Model TXD-2 pump.

2 inch line strainer on suction side, one 0.0625 inch perforation screen.

35 GPM/132 LPM rate of flow.

23. TANK, PUMP-MOUNTING:

Pump(s) to be mounted on common cradle, fabricated from 4 inch x 5.4 LB/feet (mm.) steel channel and bolted to chassis frame.

SPECIFICATIONS
A48-BT-A-AL

I. GENERAL TRUCK SPECIFICATIONS: (Continued)

E. TANK BODY & EQUIPMENT: (Continued)

24. TANK, REELS:

Two (2) electrically operated hose reels (only one reel if product tank is only specified diesel) with explosion-proof motors installed in bucket box.

Each reel shall be complete with 75 feet of two-braid hose. Ref. BRIGGS RUBBER Tel. (302) 328-9471.

Gasoline system (if applicable) to have 75 feet of 1 inch hose, with built in static line, coupled male by female. Diesel system to have 100 feet of 1 inch hose, coupled male by female. Hose reel shall be of sufficient size to easily accommodate the 100 feet of length.

Each length of hose shall be marked to indicate the manufacturer's recommended working pressure. Each reel shall be equipped with a friction-brake system.

Hose reel electrical system should consist of one (1) KLIXON, CDLA-7, 70 A circuit-breaker installed as close to battery box of chassis as possible. Hose reel solenoids should be installed in conduit box and mounted away from any area in contact with fuels. Master disconnect switch, (COLE-HERSEE No. 2484) for hose reel protection, would be installed in conduit box. Hose reel switch shall be HANNAY explosion-proof style.

25. TANK EMERGENCY, SHUT-DOWN SYSTEM:

Air operated emergency shut-down cable system.

First location: Driver's side, front of tank and identified.

Second location: Rear bucket box and identified.

Air operated emergency valve.

26. TANK, SUMP:

Standard ATA sump equipped with a 3 inch bolt-on emergency valve with grooved outlet located at the lowest point of each compartment.

27. TANK, WEIGHT DISTRIBUTION:

The aluminum tank body and aluminum cabinets shall be designed to provide proper weight distribution for the chassis cab-to-axle dimension proposed. The weight of the tank assembly less chassis weight is required at the pilot model inspection.

SPECIFICATIONS
A48-BT-A-AL

I. GENERAL TRUCK SPECIFICATIONS: (Continued)

E. TANK BODY & EQUIPMENT: (Continued)

28. TANK, WIRING AND LIGHTING:

All lights provided on tank shall meet Pennsylvania Motor Vehicle Code and Federal Motor Vehicle Standards. Two (2) red warning lights labeled gasoline and diesel shall be provided in the dashboard of truck to indicate when each pump is in gear. (1 if diesel only).

Lighting circuits shall have suitable over current protection (fuses or automatic circuit breakers). The wiring shall have sufficient carrying capacity and mechanical strength and shall be secured, insulated, and protected against physical damage, in keeping with recognized good practice. Wiring and lighting shall be per EQN-80XF.

Shelf shall be added on right side within easy reach of operator for mounting of automated fuel system. REF. EQN-80-XFA

All chassis wiring and air tubing shall be clamped every 12 to 15 inch or less, and shall include wiring per EQN-352 and 352A.

Two (2) grounding plugs without cord shall be mounted on forward end of the tank top flashing and midpoint near operator's door. All solenoid switches shall be mounted away from any area in contact with the fuels.

Dual portable ground cable with connectors on both ends for grounding the equipment being fueled in the field, shall be Hannay Reels Instruction label for proper use of the above ground cable shall be mounted in the fuel truck bucket box (EQN-88).

There shall be a posi-ground system, manufactured by Garnet Instruments, LTD, Tele. (403) 467-1010, or equal.

The above procedures are outlined in Pennsylvania Department of Transportation, Hazardous Substances Transportation Board, Specific Regulations governing the Highway Transportation of Flammable Liquids and Flammable Solids and General Regulations, Governing the Highway Transportation of Hazardous Substances, Page 13, Item no. 2, Item no. B. It shall be the responsibility of the successful tank vendor to carefully read the above regulation and provide an adequate system to comply with the letter with both the safety procedures outlined and in this statement.

Ref: NFPA Standard No. 385.

SPECIFICATIONS
A48-BT-A-AL

II. DRAWINGS:

EQN-66	dated	Rev.07-20-09	2sheets	SPLASHGUARDS-RUBER TRAILER & TRUCK
EQN-66A	dated	Rev. 07-20-09	1 sheet	TRIANGLE STORAGE BOX
EQN-78	dated	Rev. 10-27-06	1 sheet	CB RADIO CONNECTIONS
EQN-80XF	dated	Rev. 08-07-12	3 sheets	FUEL TRUCK WIRING/LIGHTING
EQN-82D	dated	Rev. 07-22-15	1 sheet	CHOCK AND HOLDER
EQN-88	dated	Rev. 07-18-07	1 sheet	GROUNDING CABLE DIAGRAM
EQN-89	dated	Rev. 07-15-99	2 sheets	LUBE TANK (AUXILIARY) DETAILS
EQN-118	dated	Rev. 06-26-09	1 sheet	UNDERRIDE PROTECTION
EQN-120Q	dated	Rev. 08-06-12	1 sheet	UNIVERSAL TRUCK LIGHTING
EQN-127A	dated	Rev. 01-02-09	1 sheet	CONSPICUITY TAPE STRIPING REQUIREMENTS
EQN-351A	dated	Rev.06-19-13	2 sheets	FAST LUBE OIL CHANGE SYSTEM
EQN-352	dated	Rev. 08-10-12	sheets 1, 2, 3 of 4	AUTOMATED FUEL SYSTEM
EQN-352A	dated	Rev. 08-10-12	sheet 3 of 3	PENNDOT FUEL TRUCK
EQN-352B	dated	Rev. 04-11-06	sheet 2 of 2	PENNDOT FUEL TRUCK TANK CATWALK LOCATION
EQN-501	dated	Rev. 06-08-09	2 sheets	CENTRALIZED LUBE SYSTEM
EQN-552	dated	Rev. 5-29-13	1 sheet	MAX. TRAVEL HEIGHT STICKER
EQN-552-1	dated	Rev. 3-23-15	1 sheet	THREE POINTS OF CONTACT

The above referenced drawings shall become part of these specifications.
These drawings reflect the intent of the Department and any discrepancies shall be resolved at the line setting ticket meeting between the vendor and the Equipment Chief, or the pre-production inspection of the truck.

DRAWINGS APPEAR AT THE END OF THE SPECIFICATIONS.

SPECIFICATIONS
A48-BT-A-AL

III. MANUALS:

The successful vendor shall furnish all applicable manuals per unit:

- 1 Operator's
- 1 Parts
- 1 Service
- 1 Engine
- 1 Transmission (Automatic or Manual)
- 1 Body and Sub-frame (Parts and Service)
- 1 Complete set of manuals for any additional items/equipment added to a piece of equipment.

The manuals listed shall be official O.E.M. publications supplemented with technical manuals for all components as published by sub-vendors/manufacturers.

Parts Manual presented must be a relative to "all" items utilized to build these units, with appropriate part numbers.

Delivery of these manuals shall be completed within a maximum of 90 days after the pilot model is accepted.

Manuals may be supplied on CD Disc in lieu of paper manuals.

SPECIFICATIONS
A48-BT-A-AL

IV. TRAINING:

Mechanic:

The successful vendor shall provide services of qualified factory trained technicians for not more than 1 training sessions of not more than 7.5 hours at 1 PennDOT locations to train personnel for in-depth preventive maintenance, overhaul and review of the proper usage of parts and service manuals, as well as component/system adjustments that need to be monitored at specified service intervals.

Operator:

The successful vendor shall provide services of qualified factory trained technicians for not more than 1 training sessions of not more than 7.5 hours at 1 PennDOT locations to train personnel in the proper operation, safety and servicing of the equipment.

The successful vendor shall submit a training plan to the Fleet Management Division for approval within 45 days after receipt of the Purchase Order. The training plan shall consist of course outline and class schedule.

All training must be completed within 60 days after the dates established in the approved training plan unless an extension is mutually agreed to in writing by the Chief of the Fleet Management Division.

All training shall be coordinated with the District Equipment Managers, with the exception of Asphalt related training, which must be coordinated with the Statewide Training Coordinator (717) 787-4836, Fax (717) 783-4438.

SPECIFICATIONS
A48-BT-A-AL

V. WARRANTY: Per PCID No. 1075

ENGINE WARRANTY:

The successful vendor and or supplying OEM shall provide the Department with a 100% parts and labor engine warranty FOR 60 months / 150,000 miles / 5,400 hours minimum. In addition to the engine warranty, the engine block shall be warranted against external perforation from corrosion for 60 months, 100% parts and labor.

NOTE: The oil pan shall be warranted against corrosion, rust, rust thru etc. regardless of atmospheric conditions for 60 months, 100% parts and labor.

EMISSION WARRANTY: The successful vendor and or supplying OEM shall provide the Department with a 100% parts and labor warranty for all emission related components to include the diesel particulate filter (DPF) FOR 60 months / 150,000 miles / 5,400 hours minimum. Shall be warranted against corrosion, rust, rust thru etc. regardless of atmospheric conditions.

RADIATOR WARRANTY:

Manufacturer service and warranty policy for radiator shall be for two (2) years, 100% parts and labor plus an additional three (3) years, 100% parts only.

TRANSMISSION WARRANTY:

Manufacturer service and warranty policy for automatic and manual transmissions shall be 60 months 100% parts and labor.

BODY ELECTRICAL/LIGHTING:

Wiring harness shall be 5 years 100% parts. First year shall include 100% labor.

All LED lights shall be 5 years 100% parts.

NOTE: WARRANTY REPAIRS SHALL BE COMPLETED AT THE MANUFACTURER'S LOCATION OR IN-HOUSE FIELD REPAIR COMPLETED BY PENNDOT. IT SHALL BE THE DEPARTMENTS DISCRETION TO REPAIR INTERNALLY OR TRANSPORT THE UNIT TO THE DEALERSHIP. THE MANUFACTURER SHALL REIMBURSE THE DEPARTMENT AT THE MANUFACTURERS STANDARD PUBLISHED IN-HOUSE LABOR RATE. THE LABOR RATE SHALL BE MUTUALLY AGREED UPON BETWEEN THE DEPARTMENT AND VENDOR/BIDDER. ALL IN-HOUSE WARRANTY DOCUMENTATION SHALL BE DELIVERED WITH THE PILOT MODEL. ALL WARRANTY DOCUMENTATION SHALL BE DELIVERED WITH THE PILOT MODEL.

SPECIFICATIONS
A-48-DB-C-AT

057700, 057900

CONV. CAB TANDEM TRUCK CHASSIS WITH OIL DISTRIBUTOR BODY

TRUCK, OIL DIST., 3K, CONV. CAB, ARC, AUTOMATIC (057700)

TRUCK, OIL DIST., 3K, CONV. CAB, ARC, MANUAL (057900)

INDEX

I. GENERAL TRUCK SPECIFICATIONS:

- A. Intent Statement
- B. Weight Distribution
- C. Power Train Overview
- D. Vehicle Components
 - 1. Axle-Front
 - 2. Axle-Rear, Tandem
 - 3. Brakes
 - 4. Cab
 - 5. Chassis
 - 6. Drive Line
 - 7. Electrical
 - 8. Engine
 - 9. Engine Accessories
 - 10. Exhaust
 - 11. Fast Lube Oil Change System (FLOCS)
 - 12. Frame and Frame Extension
 - 13. Instrumentation
 - 14. Light - Warning
 - 15. Paint
 - 16. Safety
 - 17. Steering
 - 18. Tank-Fuel
 - 19. Wheels/Tires
 - 20. Transmissions
 - 21. On-Board Grease System

SPECIFICATIONS
A-48-DB-C-AT

I. GENERAL TRUCK SPECIFICATIONS: (Continued)

E. OIL DISTRIBUTOR:

1. Alarm-Backup
2. Tank-Body-Installation
3. Cabinet, Tool Box
4. Calibration Control Console
5. Automatic Rate Control System
6. Air Controls
7. Circulation System
8. Decals and Signs (Tank)
9. Fenders (Tank)
10. Filter System
11. Fire Extinguishers
12. Flashing
13. Heating System
14. Hydrostatic Drive
15. Identification, Asphalt Tank
16. Insulation, Tank
17. Instruments and Accessories
18. Ladder, Tank
19. Manholes, Tank, & Strainer
20. Tank-Paint, Body
21. Tank, Piping
22. Platforms
23. Tank, Power-Take-Off
24. Pump, Asphalt Circulator System
25. Pump Flushing Line
26. Sump
27. Tank Inner Shell
28. Tank Outer Shell
29. Weight Distribution, Tank
30. Wiring and Lighting, Tank
31. Optional Heat Chase, Material Pump

II. DRAWINGS:

III. MANUALS:

IV. TRAINING:

V. WARRANTY:

SPECIFICATIONS
A-48-DB-C-AT

I. GENERAL TRUCK SPECIFICATIONS:

A. INTENT STATEMENT:

The purpose of these specifications is to describe a bituminous distributor for use by the Department to service road construction with bituminous materials. The vehicle shall consist of a cab, chassis, dual rear wheels and tandem rear-axle-drive, and be equipped with a tank and dispensing equipment as described.

Functions:

The distributor shall perform the following functions:

1. Fill tank by distributor pump from outside source.
2. Circulate material in tank.
3. Circulate material in spray bar.
4. Spray at a constant desired application rate, regardless of variance in truck speed and bar length.
5. Return material in spray bar to tank by pump suction.
6. Hand spray
7. Return material in hand spray to tank by pump suction.
8. Transfer from an outside source to another source without having material enter distributor tank.
9. Pump material back to supply source.
10. Heat material to proper temperature.

NOTE: Pennsylvania Department of General Services, PCID No. 1075, "*General Requirements for Bidding PENNDOT Vehicles/Equipment*", most current version effective at the time and date of bid opening, is included as a part of this specification. PCID No. 1075 may be reviewed and downloaded from the Department of General Services website, <http://www.dgs.state.pa.us>.

Delivery as required per Department of General Service PCID NO. 1075 Section "G". All units must be delivered within **270** days after receipt of the purchase order by the successful bidder.

B. WEIGHT DISTRIBUTION:

Engineering-certified weight distribution charts shall be provided with the pilot model for the equipment supplied.

It is understood that the components specified are minimum and if the truck manufacturer's Engineering Department recommends or deems necessary, due to their particular weight distribution, a larger component or a larger GAWR totally, the burden of responsibility is hereby placed upon the Manufacturer's Engineering Department to supply a unit that is totally engineered.

SPECIFICATIONS
A-48-DB-C-AT

I. GENERAL TRUCK SPECIFICATIONS: (Continued)

B. WEIGHT DISTRIBUTION: (Continued)

1. Frame
2. Axle
3. Tires
4. Steering unit of components
5. Rims
6. Suspension
7. Brakes
8. Any other items as required

The dynamic and static loads created by the unit, plus operational stresses, must be reviewed to ensure the Commonwealth of a properly designed/engineered unit.

Engineering Concurrence:

This specification and all specified components must be reviewed and approved by the successful manufacturer. The installation of the specified components must be approved by the successful manufacturer's Engineering Department.

Transmission gear (Manual or Automatic), and drive axle gear ratio selection shall be made to ensure an obtainable ground speed in the lowest useable gear of 3-5 MPH at 1300 RPM's for spraying applications. If a suitable ratio cannot be obtained, than an Eaton 1202 auxiliary transmission shall be used.

The distribution shall be made relative to the following information:

1. Payload of approximately 3,000 GAL minimum, of emulsion as permitted to provide a unit with the largest tank capacity best utilizing available GAWR's without exceeding maximum Pennsylvania GVWR.
2. Chassis fuel tank(s) and all other fluid tanks full.
3. 200 LB operator.

The vehicle shall be certified for 62,000 LB Gross Vehicle Weight Rating (GVWR). The GVWR shall be identified in the cab or on the door as the final complete certification label (minimum rating)

Actual Truck Weight

Slip requirements to be presented with the pilot model:

Chassis only	_____ <u>LB</u> Front Axle
	_____ <u>LB</u> Rear Axle
	_____ <u>LB</u> Total

SPECIFICATIONS
A-48-DB-C-AT

I. GENERAL TRUCK SPECIFICATIONS: (Continued)

B. WEIGHT DISTRIBUTION: (Continued)

"Chassis with body", if applicable, shall be split-weighed and total-weighed by a certified weight master and signed and presented with pilot model.

_____ LB Front Axle

_____ LB Rear Axle

_____ LB Total

Chassis with body and payload:

_____ LB Front Axle

_____ LB Rear Axle

_____ LB Total

Truck GAWR's as Built (LB)

Front GAWR

Rear GAWR

Axle _____

Tires _____

Truck GAWR's as Built (LB)

Springs _____

Rims _____

C. POWER TRAIN OVERVIEW:

NOTE: LUBRICANTS FOR FRONT AXLE HUBS AND DIFFERENTIALS, AUTOMATIC TRANSMISSION, TRANSFER CASES AND ALL REAR DIFFERENTIALS SHALL MEET OR EXCEED ALL APPROPRIATE MIL AND SAE SPECIFICATIONS FOR SYNTHETIC LUBRICANTS AND SHALL HAVE ALL PLUGS IDENTIFIED AS SYNTHETIC OR PAINTED RED.

(The OEM shall provide written exemption if synthetic oil is not installed).

SPECIFICATIONS
A-48-DB-C-AT

I. GENERAL TRUCK SPECIFICATIONS: (Continued)

C. POWER TRAIN OVERVIEW: (Continued)

ENGINE DIESEL -MIN. 12.4 LITER (actual engine liters), MINIMUM 425 HP AT GOVERNED RPM, and MINIMUM 1540 LB FT TORQUE.

Transmission gear (Manual or Automatic), and drive axle gear ratio selection shall be made to ensure an obtainable ground speed in the lowest useable gear of 3-5 MPH at 1300 RPM's for spraying applications. If a suitable ratio cannot be obtained, than an Eaton 1202 auxiliary transmission shall be used.

CLUTCH & MANUAL TRANSMISSION:

Manually adjustable, Solo Clutch will not be accepted.

Cast Pressure plate, Stamped pressure plate will not be accepted. Dampened driven disc.

Externally lubricated and torque limiting with a clutch brake.

Clutch shall be capable of 100 ft/lb. above peak engine torque.

Clutch adjustment shall be set to specifications prior to delivery to the Department.

There shall be a neutral safety device to ensure that the vehicle cannot be started in gear.

Note: The transmission-input shaft shall be 2 inch spline.

EATON RTO – 16908LL

EATON RTO – 14908LL

AUTOMATIC TRANSMISSION:

AUTOMATIC ALLISION 4500 RDS 6 SPEED

REAR AXLE:

DANA DS463P

Meritor RT46-164-P

MACK S462

NOTE: All rear axles must provide axle shafts with a minimum diameter of 2.19 inch at the spline.

D. VEHICLE COMPONENTS:

1. AXLE-FRONT:

20,000 LB capacity "I"-beam type, minimum.

10,000 LB capacity at ground, each front spring, minimum.

The front axle grease fitting locations must be provided with zerks.

STEMCO oil seal assembly, including hub, plug type window and GUARDIAN seal, or approved equal.

Each unit shall have the front end aligned.

SPECIFICATIONS
A-48-DB-C-AT

I. GENERAL TRUCK SPECIFICATIONS: (Continued)

D. VEHICLE COMPONENTS: (Continued)

2. AXLE-REAR, TANDEM:

23,000 LB capacity at ground each rear spring.

Suspension tailored to axle loads and adequate to sustain maximum GVW without overload or permanent set.

Inter-axle differential (power divider), (in cab controls) with lockout and warning light with pump to lubricate inter-axle differential as furnished in EATON DS461-P, the pump system furnished in the ROCKWELL SSHD or the automatic inter-axle system furnished on the Mack S462.

STEMCO oil seal assembly, complete (GUARDIAN), or approved equal.

Magnetic drain plug.

The rear axle housings shall not be aluminum or lightweight component type.

Rear axle ratio selection will be made after the award and may be a mix of ratios as required. The successful vendor/manufacturer shall present three (3) computer runs showing three (3) most likely ratios for consideration for a speed range up to 65 MPH max. This information shall be presented at the pre-build meeting.

3. BRAKES:

Braking System: Full air antilock in compliance with the most current FMVSS requirements.

The ABS shall incorporate a diagnostic fault switch that is capable of illuminating a fault light for diagnostic purposes. The switch shall be easily accessible and can be either dash or under-dash mounted. A dash-mounted display that will show all SAE message descriptions for the ABS is an acceptable means of diagnostics in lieu of the fault switch.

Rear brakes: 16.5 inch x 7 inch "S" cam with quick-change type single or double pin. (No substitute - standardization).

Drum brakes shall have automatic slack adjusters, clearance sensing with adjustment on application of the brake (no substitute).

Steer axle brake: 16.5 inch x 6 inch "S" cam or a power front disc brake system providing equal performance. Quick-change type single or double anchor pin if drum type brakes are furnished.

Backing plates on all drum brakes.

Air compressor: Per truck manufacturer's recommendation. Buzzer-type, low air pressure indicator. Compressor shall be fitted with a safety valve to prevent mechanical failure.

Parking brake: Rear wheels, spring-type, MGM E 30/30 or ANCHORLOCK 30/30 gold seal chambers (no substitute). Parking brake shall provide modulated emergency braking via the foot valve in the event of a rear service system failure.

Air tank: Automatic drain valve, with heater on wet (first) tank. Each of the remaining air tanks shall have a manual drain valve.

Air dryer: With heater, mounted away from road splashing and a minimum of 20 inches above road surface. Dryer shall be compatible with the body company clearance requirements for sub-frame, valve body, etc. Per: Haldex DRYest or Bendix AD-IP installation made in concurrence with the air compressor manufacturer's recommendations.

Air dryer shall be placed to accommodate the changing of filter cartridges without disconnecting any hoses or removing dryer base from its mounting location. Final mounting location shall be determined at Pre Build meeting. All electrical connectors for drain valve and air dryer shall be covered with heat-shrink material or have sealed connections.

System shall be equipped with anti-compounding to prevent mechanical failure of the foundation brakes, slack adjusters, etc.

SPECIFICATIONS
A-48-DB-C-AT

I. GENERAL TRUCK SPECIFICATIONS: (Continued)

D. VEHICLE COMPONENTS: (Continued)

4. CAB:

Aluminum or galvanized steel cab.

Conventional cab.

Exterior windshield sun shade (visor), color coordinated to the cab.

Fenders: Front fenders shall have extensions to cover the width of the front tires.

Air Conditioning: Manufacturer's standard highest output.

Cruise Control

AM/FM radio

Seats: Driver's seat shall be BOSTROM Air 915 Series with lumbar support, or National 2000 Series with lumbar or DuraForm Air Command Series (fabri form cushions with lumbar support), with body cloth and retractable seat belt. **(Seatbelt shall be High Visibility Orange)**. A bellow-type or protective skirt shall cover the seat suspension mechanism. **(No substitute, standardization)**.

Color coordinated to cab interior

Passenger seat: With three-point retractable seat belt **(Seatbelt shall be High Visibility Orange)**, manufacturer's standard non-suspension (static) high-back type. Color coordinated.

Note: If due to cab configuration a Bostrom 915 seat cannot be used, a Bostrom 910 may be substituted. All other requirements must be met.

Deluxe fresh air hot water heater and defroster manufacturer's highest output.

Windshield: One (1) or two (2) piece construction, tinted. Safety glass throughout.

Dual inside sun visors.

Dual windshield Wipers, shall be minimum 2-speed electric with intermittent feature.

Heaviest Wipers, arms, motor and linkages available. Washer system shall be electric. Minimum capacity of two (2) quarts of washer fluid and shall be filled with an anti-freeze type solvent.

Drivers and passenger side windows shall be power.

Mirrors: Drivers and passengers side power mirrors, west coast style minimum 7 inch X 14 inch manufacturers standard heavy-duty breakaway arms.

Mirrors shall be heated with a lighted toggle switch mounted within accessible reach of the operator, automatic on/off is acceptable. The wires shall be fitted in such a way that the mirror glass/element can be changed by unplugging the two-wire lead. There shall be a heated convex mirror both sides, minimum 6 inch X 7 inch or 8 inch diameter.

A heated blind-spot elimination mirror shall be mounted on the right front fender and it shall be minimum 7 inch X 7 inch or 8-inch diameter, stainless steel or aluminum head with mirror. Mirror shall be a conventional convex mirror, and shall not be of the half-round cross view type. All arm/s and hardware shall also be stainless steel. Fender type washers stainless, or aluminum, with rubber pads to be placed on both sides of the fender shall be included. Pedestal system shall be single, double or triple mounting assemblies (stainless steel or aluminum). Mirror shall be mounted in rubber or vinyl. Ref: Grote (800-628-0809).

Drivers and passenger cab entrance steps: Shall be aluminum, serrated. The outer step edge must be serrated in lieu of plain. (Overlay is not acceptable).

Step design material must be the same both left and right side.

Ref: Bustin No. NST4 full size, Ohio Grating No. JA21195G4 serrated, IKG. Industries Type B54 or Mack. Top of the first step shall be approximately 21 inches above the ground.

SPECIFICATIONS
A-48-DB-C-AT

I. GENERAL TRUCK SPECIFICATIONS: (Continued)

D. VEHICLE COMPONENTS: (Continued)

4. CAB: (Continued)

Grab handles shall be supplied on all cab entry locations. Three points of contact shall be achievable at all cab entry locations. Handrails shall be coated with non-skid paint (non-skid tape is unacceptable) or have OEM anti-slip rubber inserts, both non-skid paint or rubber inserts must extend the full length of the grab handle.

Exterior grab handles shall be supplied if available from OEM.

There shall be a permanent decal, 2 inch high red letters on white back ground affixed by the driver side door handle stating the overall maximum travel height of the completed and unloaded unit.

(Example) HT-__' __" Ref. EQN-552

There shall be a permanent decal, "Three Point Contact" located at each entry point of the truck cab and at the bed ladder area per EQN – 552-1. Exact location to be determined at pre build meeting.

Driver armrest. Seat shall have a fold-up armrest on the right side of the driver's seat.

Air horn(s): With protective cover(s).

All controls and knobs shall be properly identified.

The cab floor covering shall be heavy-duty rubber with closed cell rubber or heavy felt backing.

Cabs shall have air suspension.

Steering wheel diameter shall be 18 inch (approx.) Manufacturers standard.

Steering Column: Steering wheel and column shall be tilt and telescopic, infinitely adjustable to multiple positions.

5. CHASSIS:

62,000 LB GVWR minimum, manufacturer's rating.

Cab Axle (CA) dimension: Wheel Base (WB) and CA dimension to be determined and adjusted by the manufacturer to provide the optimum legal weight distributions with maximum payload.

Front Bumper: Heavy duty. To accommodate an 8 inch wide flat sign, mounted flush.

Front mounted tow hooks or eyes: Two (2) front or one (1) severe-duty centered.

6. DRIVE LINE:

Main driveline: Spicer Life XL or Meritor MXL Series. "**Factory balanced**" greasable, (one zerk minimum). Heavy-duty driveline shall be engineered and be compatible to engine, drive train and transmission torque. Heavy-duty center bearing, if required, with due consideration to drive shaft angles, length, location, proper bolting based upon engine and transmission selection. Inter-axle driveline: Spicer Life XL or Meritor MXL Series.

SPECIFICATIONS
A-48-DB-C-AT

I. GENERAL TRUCK SPECIFICATION: (Continued)

D. VEHICLE COMPONENTS: (Continued)

7. ELECTRICAL:

All copper system, negative ground.

Battery location to be determined at the pre-build meeting.

Batteries: Three (3), 12-volt, maintenance-free, BCI Group Size 31, with stud-type posts and anti-corrosion treatment on each terminal. 2500 total cold cranking amperes (CCA) min.

Battery Mounting: It shall include the following:

a.) 0.25 inch thick rubber shock pad under the battery.

b.) Box with cover. Cover shall be constructed of fiberglass, poly, or aluminum (if aluminum, there shall be an insulating liner). **Mounting of accessories within the battery box is unacceptable. All fuses and circuit breaker shall be labeled.**

c.) Mounting bolts grade-8 with self-locking nuts.

Cables shall conform to RCC Practice 105 "sealed" terminal ends for stud-type battery posts.

Electrical system: Circuit-breaker-equipped, in easily accessible location, weatherproof. Fuses acceptable in circuit so identified by manufacturer as safety factor. Any fuse or circuit breaker liable to be damaged during truck operation shall have an easily removable protective cover. All connections shall be made using sealed connections and dielectric grease.

Alternator: Delco 36SI (No substitute, Standardization) 160 A minimum, high performance, solid state (brushless).

Starter motor: Delco 39 MT (No Substitute, Standardization) with thermal over-crank protection and high torque capacity. Suitable for the diesel engines offered as per starter manufacturer's recommendation.

Note: Starter shall have (OCP) either built in or controlled by the Vehicle's control system, (if required)

Battery cable from battery negative terminal to the truck frame and from the battery or frame to the starter motor.

Alternator and starter mounting bolts: Grade 8.

Power supply for two-way radio: Quantity (1). Dash mounted. Both male/female ends shall be supplied, Ref: EQN-78.

GPS Combo Radio Antenna: There shall be a pedestal mount base with built-in GPS, PCTEL model GPPB-204-54-12-S1-M1 and a low profile black antenna, PCTEL model BMLPU700. Assembly shall be mounted on pedestal (**with mini light bar**) with the antenna cable routed to the floor area between the seats. There shall be a minimum of 4 feet of antenna cable coiled at the base of the floor to allow for connection of department radio. Antenna shall be prewired with a MINI - UHF MALE connection. (No substitute, standardization). No mounting in roof. REF. EQN-120Q

Power Distribution Center: There shall be a 4-way power/ground distribution center located on the underside of the dash for connection of department state radio. The lugs shall be configured in the following manner: (1) lug shall be a 30 ampere constant hot circuit, (1) lug shall be a 10 ampere ignition controlled circuit. (2) lugs shall be chassis ground. All connections shall be enclosed in a weatherproof enclosure.

Electrical wiring: Chassis wiring harness protected at areas prone to cause chafing by installing convoluted plastic conduit and clamped using steel band clamps with rubber inserts.

All pass-through points shall be properly sealed and protected.

Flasher: (All) heavy-duty electrical, Ref: Tridon Model EL 12 or equal.

Note: If an audible alarm is supplied for 4 ways and turn signals, it shall have an on/off capability.

SPECIFICATIONS
A-48-DB-C-AT

I. GENERAL TRUCK SPECIFICATIONS: (Continued)

D. VEHICLE COMPONENTS: (Continued)

8. ENGINE:

Replaceable heavy-duty full flow type fuel filter(s) and oil filter(s) as recommended by the engine manufacturer. **And bearing a legible OEM part number.**

Cooling system: The largest factory available capacity compatible with engines and transmissions referenced and for continuous high engine output under extreme temperatures and/or operations conditions due to prolonged slow ground speeds while applying the asphalt material. With overflow recovery system and visual level indicator.

Radiator core and shell: Shall be manufacturer's heaviest construction grade radiator available, with overflow recovery system and visual level indicator.

9. ENGINE ACCESSORIES:

Automatic idle shutdown shall be set to five (5) minutes. An audible warning alarm shall be provided to alert operator prior to engine shutting down. Automatic idle shutdown shall be programmed to be overridden when the PTO Mode is engaged.

ECM shall be set to a maximum of sixty five (65) miles per hour.

Engine Heater: Immersion in-block type, for cooling system, with waterproof plug flush-mounted in an accessible location at the front/roadside of the vehicle, outside the cab/hood, 115 volt, 3-prong plug. The electrical cable from the heater to plug shall be one piece and waterproof.

Coolant filter: A non-charged spin-on coolant filter shall be installed only if required by engine manufacturer.

Air Cleaner: Heavy Duty Capacity adequate for maximum performance of the engine.

Fan: Thermostatically controlled, viscous type.

Screening system: Mounted behind radiator grille that protects radiator from stones and bugs. System to be approved by engine and truck manufacturer(s).

Diesel Fuel Filter: There shall be a DAVCO 382 or a 482 filtration unit installed and mounted (Higher than fuel tank) per manufactures recommendations in a location to accommodate filter replacements, yet be protected from road debris **(No substitute, standardization)**.

Mounting location to be determined at pre-build meeting.

Davco 382 Unit shall be equipped with engine coolant heat and 120 volt heater circuit. The 120 volt circuit and engine block heater shall be powered via the same electrical connection. **(No substitute, standardization)**

Davco 482 shall be equipped with a 12 volt and 120 volt heater circuit. 12 volt heater circuit will activate with the ignition key switch, the 120 volt heater circuit and engine block heater shall be powered via the same electrical connection. **(No substitute, standardization)**. Air restriction gauge: Flush, dash-mounted with indicator slide for engine air cleaner, RE: FILTER MINDER, manufactured by Engineered Products Company, or prior-approved equal.

Governor: Set at manufacturer's recommended maximum engine speed (rpm).

Lubricating oil lines: High quality flexible wire braid type, "AEROQUIP" or approved equal system, minimum standard if hoses are used.

Engine Brake: Engine shall be equipped with a minimum 2 stage, full engine compression brake.

Brake lights shall activate when engine brake is activated Ref: Jacobs.

SPECIFICATIONS
A-48-DB-C-AT

I. GENEAL TRUCK SPECIFICATIONS: (Continued)

D. VEHICLE COMPONENTS: (Continued)

10. EXHAUST:

DPF (diesel particulate filter) and exhaust system shall meet the latest EPA emission requirements. Vertical tailpipe with elbow and muffler system or approved horizontal muffler and vertical tail pipe with elbow. Exhaust system shall not be close to any fluid tank or any hoses. The DPF, muffler and tail pipe shall be shielded or insulated to protect personnel from burns when entering or exiting the cab. The shield shall be 180 degrees to 360 degrees and shall be of non-rustable material such as stainless steel or aluminum. RE: RIKER or equal.

11. FAST LUBE OIL CHANGE SYSTEM (FLOCS):

This FLOCS system shall be installed with all fittings, brackets, clamps and hoses. Hose from oil pan to FLOCS fitting shall be hydraulic hose with a 100R2 rating and properly secured. The system shall be compatible with all fittings presently used by the Department. The final placement of the male half of the snap coupler, on the equipment, shall be determined at the pre-build meeting. Ref: EQN-351A.

12. FRAME:

Resisting Bending Moment (RBM): Minimum of 2,800,000 inch LB per rail at high-stress areas and 2,086,000 inch LB at non-high-stress areas, for the entire length of the frame, and any frame reinforcements. Minimum frame RBM shall be approved by manufacturer's Engineering Department.

Frame material: Heat treated carbon steel, at least 110,000 psi yield strength.

Main frame and any required liners: Either straight channel or offset channel, full length. Drop frames are not acceptable. Minimum 96 inch deep section.

Frame AF extension: An integral and continuous extension of the main-frame side rail section modulus. Bolt on or welded extensions are acceptable. Length sufficient to properly mount body and equipment.

13. INSTRUMENTATION:

All instruments illuminated and dash-mounted except where specified otherwise. All standard instruments shall be supplied, including, but not limited to the following:

Gauges: Oil pressure gauge: with warning light or audible alarm.
Air pressure: gauge(s) for dual circuit, dual indicator with low pressure audible alarm.
Coolant temperature: with warning light or audible alarm.
Transmission oil temperature: for automatic transmission only, with warning light or audible alarm.
Fuel gauge
Hourmeter that records only when the engine is running. Ref: DATCON or equal.
Speedometer with odometer.
Tachometer for engine and power-take-off.
Voltmeter
Parking brake indicator light.

SPECIFICATIONS
A-48-DB-C-AT

I. GENEAL TRUCK SPECIFICATIONS: (Continued)

D. VEHICLE COMPONENTS: (Continued)

14. LIGHT - WARNING:

All lights shall meet all Federal and State regulations. The head Lights shall be Halogen with (DRL's) daytime running lights. Factory or aftermarket installation. Body lights shall have their own dedicated complete circuit. All lights including the body shall be LED.

Whelen Light Kit Part # PADOTSY8, Kit contains the following lighting. EQN – 120Q

1 - R10PADOT Light Bar to be pedestal mounted on the top driver's side, front of body. In no case shall the light bar be mounted on the roof of the vehicle.

2 - M6AD Amber warning lights with brush guard mounted to the rear of body

2 - M6BTDD Stop, Tail, Turn lights with brush guard

2 - M6BUD Back-up lights with brush guards

4- LINZ6AD Amber warning lights, grommet mounted, flush mounted 1 to each side (middle/center) of bed and 2 flush mounted and equally spaced in the front grill per EQN – 120Q.

Warning lights are to be wired in conjunction with above light bar.

4 - LINZ6 Grommet Kits

10 - W441D Harness side mating Deutch connectors.

The above lights are supplied with male and female Deutsch connectors that shall be utilized to connect the vendor supplied harness to each light source.

There shall be a Truck-Lite Model# 36140C LED license plate light with light bracket PN# 36710 (Installed).

Body builder to supply remaining marker and ICC lighting, they shall be protected against damage and shall also be shock mounted. Connections shall be water tight.

The Warning lights / Light bar shall have a lighted, permanently labeled toggle switch located in the dash.

Body wiring shall be Grote, Trucklite, or Prior Approved Equal.

There shall be no splices outside of a sealed box or fixture.

A color-coded electrical wiring chart and schematic shall accompany each body.

15. PAINT:

Cab shall be painted PennDOT yellow Ref: DuPont F9885, PPG 85246, Sherwin Williams 73266, Sikkens 4017 or NAPA 73266 for shade only. Frame and all underside components shall be painted black. Front bumper and frame shall be primed and painted black (with hardener) low VOC. All bare metal surfaces shall be coated using etching primer prior to paint. All surfaces shall be properly cleaned and prepared prior to paint, with all weld splatter and debris removed.

All tank components that are not polished aluminum or stainless shall be painted black.

16. SAFETY:

Cab shall have reflective enhancement per EQN-127A.

Anti-slip paint is required on all handholds, for the entire length, (tape is unacceptable). All handrails, ladders, and step configurations shall be built for three points of contact.

There shall be a permanent decal, 2 inch high red letters on white back ground affixed by the driver side door handle stating the overall maximum travel height of the completed and unloaded unit. (Example) HT-__' __" Ref. EQN-552.

There shall be a permanent decal, "Three Point Contact" located at each entry point of the truck cab and at the bed ladder area per EQN – 552-1. Exact location to be determined at pre build meeting.

SPECIFICATIONS
A-48-DB-C-AT

I. GENERAL TRUCK SPECIFICATIONS: (Continued)

D. VEHICLE COMPONENTS: (Continued)

16. SAFETY: (Continued)

There shall be two wheel chocks per truck Ref: buyers WC1467 or equal with a rope. Mounting location will be determined at pre-build meeting.

All corners shall be angled or rounded for safety.

There shall be a triangle warning kit mounted in the cab.

Fire extinguishers 3A:40BC 5lb. rechargeable with vehicle mount. Mounted in the cab for easy and quick access.

Ref: EQN-66A, EQN-82.

17. STEERING:

Power steering: Dual-integral or single-integral type hydraulic

Steering system (e.g. flow, pressure, relief valve etc.) shall be selected considering the full front axle loading. Ref. ROSS, SHEPPARD or TRW gear assembly.

Hydraulic supply pump: Vane type or roller type, with sufficient oil flow to permit one (1) steering wheel revolution per second with front axle loaded to capacity, in a "park" condition. Ref.: VICKERS V-20, EATON or BORG WARNER. The pump shall not be the integral filter type unit.

Power Steering Reservoir: "Remote-mounted", and factory-mounted, minimum two (2) quart capacity, incorporating a filter, which is easy to remove and replace.

Steering wheel diameter shall be 18 inch (approx). Manufactures' Standard.

Glidecoat steering shaft, Bendix wedge lock lube-for-life shaft or ZF type steering shaft.

18. TANK - FUEL:

Safety - type fuel tank as per the requirements of FMVSS. **Dual tanks are unacceptable.**

One (1) 100 GAL minimum total capacity, frame mounted. (Mounted drivers side)

Cylindrical. Aluminum or stainless steel, unpainted.

Heavy-duty mounting 2 inch wide stainless steel straps with rubber shims/liners.

Tank mounting hardware and brackets shall be for "severe duty" applications.

Accessible fill pipe, (located at either end of tank to avoid interference with steps).

SPECIFICATIONS
A-48-DB-C-AT

I. GENERAL TRUCK SPECIFICATIONS: (Continued)

D. VEHICLE COMPONENTS: (Continued)

19. WHEELS/TIRES:

The truck shall be equipped with hub piloted steel disc wheels for tubeless tires. The wheel end shall be equipped with outboard cast brake drums, and 15 degree tubeless steel wheels, hub piloted, 10 hole - 285.75mm bolt circle with 22mm two-piece flange nuts.

Front: Wheels: 22.5 x 12.25, 10 hole - 285.75mm bolt circle with 220mm bore, tubeless steel disc wheel rated at 10,500 LBS at a maximum inflation pressure of 120 PSIG. Accuride part number 29806 or 29807. **(No substitute, standardization).**

Rear: Wheels: 22.5 x 8.25, 10 hole - 285.75mm bolt circle with 220mm bore, tubeless steel disc wheel rated at 7,500 LBS at a maximum inflation pressure of 120 PSIG. Accuride part number 28828 or 29169. **(No substitute, standardization).**

The dual rear wheel/tire assembly shall have clearance between the tires, which permits the use of dual tire chains.

Wheel-Guard Separators: The wheel ends shall be equipped with the Accuride part number 5903 Wheel Guard Separator as follows:

Front axle - between the wheel and the brake drum.

Rear axle - between the inner dual and the brake drum and between the inner and outer duals.

Paint: The wheels shall be topcoat painted with TGIC Polyester Powder Paint MLD-82008 High Gloss Gray or equal applied over Cathodic Electro-Disposition Gray Primer.

Tires: All tires shall be radials.

Front Tires: 425/65R22.5 (Load Range L).

Rear Tires: 12R22.5 (Load Range H).

MANUFACTURER

Goodyear

Michelin

Bridgestone

FRONT TIRE

G-296

XZY3 Wide Base

M854

REAR TIRE

G-282 MSD / G-622 RSD

XDN-2

L320

SPECIFICATIONS
A-48-DB-C-AT

I. GENERAL TRUCK SPECIFICATIONS: (Continued)

D. VEHICLE COMPONENTS: (Continued)

20. TRANSMISSION

Oil cooler for transmission required due to prolonged transmission torque converter operation in low gears. Cooler size must be provided to keep the transmission fluid at an acceptable operating temperature under these prolonged conditions. (Water-to-oil type cooler.) An Allison approved cooling system shall be installed regardless of whether retarder is incorporated in the system or not. Automatic transmission cooler lines shall be stainless steel or a **preapproved** no-rusting material.

NOTE: All vehicles shall have a clutch-operated or transmission-operated safety starting switch.

NOTE: Transmission gear (Manual or Automatic), and drive axle gear ratio selection shall be made to ensure an obtainable ground speed in the lowest useable gear of 3-5 MPH at 1300 RPM's for spraying applications. If a suitable ratio cannot be obtained, than an Eaton 1202 auxiliary transmission shall be used.

21. ON BOARD GREASE SYSTEM

There shall be a centralized on board chassis lubrication system installed. Ref: EQN-501.

SPECIFICATIONS
A-48-DB-C-AT

I. GENERAL TRUCK SPECIFICATIONS: (Continued)

E. OIL DISTRIBUTOR:

The design of the tank and its equipment shall meet regulations of the United States Department of Transportation, Hazardous Substances Transportation Board, for asphaltic materials having a flash point of 100 degrees F or higher and shall comply with the Federal Motor Carrier Safety Regulations title no. 49, as applicable.

1. ALARM - BACKUP:

Ecco Model 450, shock mounted.

2. TANK - BODY - INSTALLATION:

It shall be the responsibility of the successful vendor to have this tank mounted on the specified chassis. The installation shall be engineered and approved by the vehicle manufacturer

Tank Mounting: The tank mounting shall be as low as possible

Tank Gauge: Float type with dial calibrated in 50-GAL increments, located in ground positioned to allow unobstructed visibility.

Measuring Stick: Steel or aluminum, calibrated in 50-GAL increments. Designed and calibrated to read tank contents.

Any tank-mounted accessory required shall be mounted on a pad which is welded to the tank in lieu of welding the accessory directly to the tank. E.g. steps, catwalk, etc.

All mounting brackets attached to the truck body shall be stainless steel and shock mounted.

3. CABINET, TOOL BOX:

Stainless steel hinges.

Drip edge over top of doors, plus 3 inch overhang on both sides of door.

Watertight doors-gaskets required.

Key-locked, with matching keys.

Installation on frame rail, or supported by skirting and tank shell, size as permitted.

Corrugated rubber matting to facilitate full shelf size

4. CALIBRATION CONTROL CONSOLE:

The truck cab-mounted console shall provided the following functions and controls properly identified:

- a. Spray-bar on-and-off switch with controls in cab and at rear operator platform, or only in the cab.
- b. Electronic sensing device (no substitute, mechanical unacceptable).
- c. High and low level bitumen indicator light and an alarm audible from the front or rear of unit.
- d. High temperature hydraulic oil warning light.
- e. Variable-displacement hydrostatic pump control.
- f. Control to increase pump speed for loading and unloading.
- g. Front and or rear suction devices, air or electric over air operated.

SPECIFICATIONS
A-48-DB-C-AT

I. GENERAL TRUCK SPECIFICATIONS: (Continued)

E. OIL DISTRIBUTOR: (Continued)

5. AUTOMATIC RATE CONTROL SYSTEM:

This system will be capable of the following as a minimum.

- a. Fully cab-controlled.
- b. Wing lift and lower (also rear control).
- c. Bar lift and lower (also rear control).
- d. Bar side shift, 26 inch overall, 13 inch from center. Also rear control.
- e. Spray width controlled in increments of minimum 12 inch maximum 24 inch on Main Bar and 12 inch on wings.
- f. Solvent injection system to clean bar and outside of unit. (Front or rear control).
- g. Fully self-adjusting mechanism to control application rate regardless of spray bar width and ground speed (if specified as automatic rate control).
- h. System will be capable of loading and unloading with full pump capacity and still retain preset rate selection (if specified as automatic rate control).
- i. All digital readout gauges, gallons per mm and feet per minute.

6. AIR CONTROLS:

Distributor shall be equipped with driver-operated air controls. Air for the controls shall be obtained from the air system on the truck chassis. The distributor air system shall include its own air reservoir (using truck chassis reservoir not acceptable) with check valve set at 80 PSI to prevent loss of air on truck chassis brakes in case lines are ruptured. Truck manufacturer's engineering concurrence required. Relief valve on tank air system shall be set at 80 PSI. System shall have its own air line oiling device.

7. CIRCULATION SYSTEM:

Quick-connecting coupler for attaching loading hose to distributor fill and discharge lines shall be provided.

Strainer in filling line.

Filling line shall be above the intake valve.

Pump discharge or suction strainer shall be provided to keep foreign matter from plugging nozzles, easily removed for cleaning.

Internal fill line with anti-siphoning dome or closing valve to prevent material from flowing into pump when tank is full.

The circulating system to spray bar shall be constructed using steel piping and/or ball joints and/or flexible lines using high pressure rubber or steel hose for flexibility and "optimum safety" due to potential high temperature material.

SPECIFICATIONS
A-48-DB-C-AT

I. GENERAL TRUCK SPECIFICATIONS: (Continued)

E. OIL DISTRIBUTOR: (Continued)

7. CIRCULATION SYSTEM: (Continued)

a. Spray Bar:

- i. Type: Full-circulating, shut-off at nozzle, 16 feet minimum in length, hinged or retractable for traveling. Length of bar in folded position not to exceed 8 feet. Bar shall be air operated or hydraulic operated to shift bar 26 inches and raise for traveling.
- ii. Spray bar valves: There shall be an individual valve and quick disconnect for each individual valve.
- iii. Nozzles: Spaced on 4 inch centers on spray bar. A complete set of brass slotted non-clogging nozzles to be provided on the machine as defined below.
- iv. Relieving leak-proof sections on each side of spray bar shall allow bar ends to bend backward or forward if an obstruction is hit.
- v. Cutoff switch on wing that prevents accidental spraying when wings are raised.

Each unit shall be fitted with one complete set of emulsion nozzles AC-20 and two (2) end nozzles. The spray bar shall consist of 16 ft of spray bar.

b. Hand Spray Unit:

Each unit shall be furnished with a steel reinforced rubber hand spray hose, 25 feet x 1 inch (ID) with a steel or aluminum hand spray gun with cold handle and 2 spray nozzles. A on and off control valve shall be provided.

A means must be provided to clean out the hand gun and hose assembly, and to suck back the material left in the hose assembly and hand gun.

8. DECALS AND SIGNS (TANK):

The tank shall have all necessary appropriate material warning decals on all sides mounted in unobstructed view to alert near-by personnel of tank contents and operational hazards as required by Federal and State Standards.

Appropriate placards shall be provided as per 49CFR.

There shall be a permanent decal, "Three Point Contact" located at each entry point of the truck cab and at the bed ladder area per EQN – 552-1. Exact location to be determined at pre build meeting.

SPECIFICATIONS
A-48-DB-C-AT

I. GENERAL TRUCK SPECIFICATIONS: (Continued)

E. OIL DISTRIBUTOR: (Continued)

9. FENDERS (TANK):

Bolted fenders or catwalk/fender, removable type.

Tank fenders shall be full, flanged type using 0.080 inch aluminum or mild steel construction, or catwalk and integral steel fender assembly.

Mud flaps front and rear of rear wheel, fenders to meet Motor Vehicles Code. Rear mud flaps, 6 inch off-deck.

NOTE: If skirting incorporates the fenders design, disregard these fender requirements.

There shall be full width back-flap/mg fabricated from black 0.2500 inch rubber. (Final location shall be made at the pre-build meeting.)

10. FILTER SYSTEM:

The tank pump shall be protected by means of strainer to eliminate foreign material entry. The strainer shall be easily accessible for cleaning.

11. FIRE EXTINGUISHERS:

Shall comply with NFPA Standard No. 385, and General Regulations governing the Highway Transportation of Hazardous Substance and Federal Motor Carrier Safety Regulations, Title 49.

Two (2) rechargeable 10 LB dry chemical 20BC-rated fire extinguishers with charge condition indicator and red waterproof snap-on covers. One (1) extinguisher mounted at right front side of the tank and one (1) mounted at the front of the tank on the driver's side near the cab.

12. FLASHING:

The tank shall have gutter type flashing for hose support including brackets on the right or left side to store the fill hose.

13. HEATING SYSTEM:

a. FLUE:

One (1) 0.172 inch (8 gauge) to 0.125 inch (11 gauge) U-type minimum 6 inch steel flue, located below center of tank for fast heating of load and heating of small amounts of material. Flue welded to flanged openings in tank rear head and supported by sleeves in surge plates to prevent wear and allow for expansion. Stainless steel external exhaust stack with hinged cover and stainless steel hinge pin to prevent heat loss, or a system approved by manufacturer's engineering department. Flue exhaust opening on right or left side of tank away from operator. The inlet and exhaust opening of the flue shall be in the same horizontal plane, allowing heating with a minimum of material in the tank. Flue shall run the full length of the tank. Exhaust shall not be directed at any component.

SPECIFICATIONS
A-48-DB-C-AT

I. GENERAL TRUCK SPECIFICATIONS: (Continued)

E. OIL DISTRIBUTOR: (Continued)

13. HEATING SYSTEM: (Continued)

b. BURNER:

One (1), minimum, oil-fired atomizing-type with minimum capacity of 935,000 Btu per hour burner with pressure regulator, valves, piping, blower, flue liner, fuel pump, with solid state electronic ignition.

14. HYDROSTATIC DRIVE:

Note: Automatic transmission driven PTO

Manual transmission engine driven PTO.

- a. Variable displacement hydraulic pump.
- b. Hydrostatic motor.
- c. Type: Hydrostatic transmission.

NOTE: Hydraulic oil may reach temperatures up to 200 degrees F without damage to the unit.

Unit shall have internal valving, and shall be fitted with relief valve and high oil temperature signal in cab.

- d. Flywheel Type full time live power.
- e. Hydraulic Lines:

- i. High-pressure hose with swaged type split flange "O" ring fittings as per SAE standards.
 - ii. Low-pressure hose installation shall be made according to transmission manufacturer's recommendation. Only top quality fittings, tubing and hoses to be used.
- f. Controls: Micro-control of hydrostatic transmission for setting asphalt pump discharge rate shall be located in truck cab. Control to permit stopping the variable pump discharge without disconnecting the drive and be equipped with an override of the micro-control which shall allow increases in asphalt pump output for filling, sucking back, etc., without affecting application rate setting. (Only applicable if automatic rate control specified).

15. IDENTIFICATION, ASPHALT TANK:

The gallon capacity shall be shown as:

- a. Maximum capacity - gallons/liters
- b. Legal capacity - pounds of payload

A heavy metal tag, minimum 0.063 inch (16 gauge) steel or aluminum identifying the above information shall be attached.

SPECIFICATIONS
A-48-DB-C-AT

I. GENERAL TRUCK SPECIFICATIONS: (Continued)

E. OIL DISTRIBUTOR: (Continued)

16. INSULATION, TANK:

The thermal insulation between the inner shell and outer jacket, including bulkhead, shall be a minimum of 2 inch fiberglass or mineral wool with a density of 1 LB per cubic foot. The insulation shall be installed and bound to prevent shifting or sagging. (Vendor shall verify insulation compliance's). Spacers shall be furnished to prevent insulation compression and collapse.

17. INSTRUMENTS AND ACCESSORIES:

a. Thermometers:

- i. A 2 inch minimum dial size, dial type, 50 degrees F to 500 degrees F. REF: WEISS or equal.
- ii. A steel-armored and engraved pencil type thermometer shall be located next to the dial thermometer in a blind well.

b. Loading Hose:

Each unit shall be furnished with a 3 inch x 15 feet steel flexible loading hose with male threaded ends and vendor's quick couplers.

c. Hydraulic Hose Clamping:

Ref: EQN 94. HYCON or equal clamps, as required.

18. LADDER, TANK:

Full length ladder, 12 inch step increments and 16 inch wide. First step height approximately 12 inch to 16 inch above ground level. A folding step shall be used below the ICC bumper with the ability to be locked in the up position during operation or transportation, with step in the folder position it shall provide the same clearance as the ICC bumper.

A safety decal shall be furnished and installed at the ladder location.

There shall be a permanent decal, "Three Point Contact" located at each entry point of the truck cab and at the bed ladder area per EQN – 552-1. Exact location to be determined at pre build meeting.

1 inch minimum OD tubular handrails. Ladder reinforcements shall be dual and sturdy in design.

Ladder location shall be determined at the pre-build meeting.

Steps/ladders shall be serrated swage lock with end band steel or aluminum. (Overlay is unacceptable)

The outer step edge must be serrated in lieu of plain, smooth metal edge.

All edges must be banded on the outer perimeter.

Steps/ladders design and material shall be the same design and material on the left and right side of the equipment if applicable.

Referenced acceptable material – Bustin NST4, Ohio Grating JA2119SG4 or IKG Industries BS4.

Landing/s and or catwalks shall be furnished using plain non-serrated safety grating, manufacturer's standard according to tank configuration.

SPECIFICATIONS
A-48-DB-C-AT

I. GENERAL TRUCK SPECIFICATIONS: (Continued)

E. OIL DISTRIBUTION: (Continued)

19. MANHOLES, TANK & STRAINER:

a. Manholes:

18 inch to 20 inch minimum, non-relieving type manholes, in accordance with the most current Federal guidelines. Cover shall be furnished with woven-wire impregnated composition gaskets. Cover shall be hinged and quick-opening type.

b. Strainer:

Strainer removable type designed to fit inside the above manhole.

c. Spillage Collar:

Circular or rectangular collar around manhole with 3 inch internal drain with expansion joint to catch any excessive material overflow while loading, and shall drain excess material onto the ground.

20. TANK-PAINT, BODY:

Anti-slip paint is required on all handholds, for the entire length, (tape is unacceptable).

All handrails, ladders, and step configurations shall be built for three points of contact.

All non-aluminum parts shall be primed and painted black.

The tank body shall have conspicuity tape on left and right side, full length Ref: EQN-127.

Under no circumstances shall the aluminum skin be painted.

21. TANK, PIPING:

The tank plumbing shall incorporate a Department-approved sampling valve.

22. PLATFORMS: Ref: EQN-231

a. Tank Top:

A minimum of 54 inch x 54 inch square manhole platform, or 32 inch x 32 inch spill-box assembly (total overall).

b. Operator Station:

Operator platform to provide access to all rear distributor controls, if required.

Adequate hand rails for operator safety and proper entry and exit locations.

All sensor wiring shall be protected by piping and easily removable for service.

If all controls are accessible from ground level, additional platform is not necessary.

SPECIFICATIONS
A-48-DB-C-AT

I. GENERAL TRUCK SPECIFICATIONS: (Continued)

E. OIL DISTRIBUTOR: (Continued)

23. TANK, POWER-TAKE-OFF:

Extending the bumper forward to accommodate a pump that is placed forward of the bonnet (hood) is unacceptable.

24. PUMP, ASPHALT CIRCULATOR SYSTEM:

Pump: Positive displacement type, minimum capacity 400 GPM. Located to provide a constant head pressure in order to eliminate pump cavitation.

Tank: With front and rear suction devices.

Connection to hydraulic motor: Pump to be connected to the hydraulic motor by a double universal coupling or a thermoid coupling or direct coupled 3:1 gear box. Coupling shall be fitted to provide proper flexibility and reliability due to minor misalignment of hydraulic motor and pump shafts.

To prevent the contamination collected in the discharge strainer from re-entering the pump and tank, the clean-out system shall be filtered or so designed as to prevent this from occurring. Units with filter system shall incorporate a clean-out sump. All vendors must provide adequate plumbing to provide this option to eliminate the potential of abrasive materials being continually passed through the pump.

Recirculating cleanout system: Unit shall be equipped a with recirculating cleanout system, this system shall consists of a separate solvent holding tank mounted on the distributor with necessary valves and piping to circulate solvent through the spray-bar, asphalt pump and piping for cleaning, and then return the solvent to the holding tank. The system is to allow for the use of clean fuel from the diesel burner supply tank as solvent and also allow reusing solvent from the holding tank.

25. PUMP FLUSHING LINE:

A pump flushing line, completed with valve, shall be supplied at a minimum.

26. SUMP (if applicable):

Designed and manufactured to allow all material in tank to flow by gravity into pump or sump.

27. TANK INNER SHELL:

The tank capacity shall be approximately 3,000 GAL LPM "MINIMUM" relative to maximum utilization of each GAWR of the truck chassis.

The tank shall be constructed of 0.141 inch (10 gauge) thick steel.

The tank heads shall be a minimum 10 gauge thick, dished and flanged or 8 gauge flat, and shall be fully welded inside and out, continuous electric welding.

The inner tank shall incorporate two (2) "full cross section" material surge baffles 0.141 in (10 gauge) thick. The baffle shall have crawl spaces (staggered) for a man. The baffle shall provide for material drainage and air circulation and shall be welded continually.

Overflow: A minimum of 3 inch diameter, extending a minimum of 6 inch above the tank to prevent loss of material due to material surging while transporting. This overflow pipe shall be located near the tank center. The overflow shall provide proper drainage through the bottom of the tank in a location to clear all truck accessories and equipment.

SPECIFICATIONS
A-48-DB-C-AT

I. GENERAL TRUCK SPECIFICATIONS: (Continued)

E. OIL DISTRIBUTOR: (Continued)

28. TANK OUTER SHELL:

The tank outer jacket shall be from 0.040-inch thick aluminum of grade 5052-H38, or 0.050 inch thick aluminum of grade 3003-H14.

The outer shell shall be fabricated with sufficient overlap to prevent rain and water entry into the insulation area and constructed in such a manner as to allow for expansion and contraction.

29. WEIGHT DISTRIBUTION, TANK:

The tank body and cabinets shall be designed to provide proper weight distribution for the chassis cab-to-axle dimension proposed. The weight of the tank assembly less chassis weight is required at the pilot model inspection.

30. WIRING AND LIGHTING, TANK:

All lights provided on tank shall meet Pennsylvania Motor Vehicle Code and all wiring shall be Grote Ultra Blue seal throughout. All lights shall be sealed, shock mounted. Wiring shall conform in gauge and color with ATA Standard for asphalt transports. There shall be no connections made outside of a weatherproof box.

31. OPTIONAL PUMP HEAT CHASE:

OPTION: If specified, the unit/s shall be equipped with a heat chase from the truck engine cooling system installed. This system consists of two ball valves necessary piping and a jacketed material pump that will allow engine coolant to circulate and heat the material pump.

SPECIFICATIONS
A-48-DB-C-AT

II. DRAWINGS:

EQN-66	dated	Rev.	07-20-09	2 sheets	SPLASH GUARDS-RUBBER
EQN-66A	dated	Rev.	07-20-09	1 sheet	TRIANGLE STORAGE BOX
EQN-78	dated	Rev.	10-27-06	1 sheet	CB RADIO CONNECTIONS
EQN-82D	dated	Rev.	07-22-15	1 sheet	CHOCK AND HOLDER
EQN-94	dated	Rev.	04-18-13	sheet 1 of 2	HOSES AND COUPLERS
EQN-120Q	dated	Rev.	08-06-12	sheet 1	TRUCK LIGHTING UNIVERSAL
EQN-127	dated	Rev.	03-01-07	1 sheet	CONSPICUITY TAPE
EQN-127A	dated	Rev.	01-02-09	1 sheet	REFLECTIVITY ENHANCEMENT
EQN-231	dated	Rev.	06-12-07	1 sheet	TANK CATWALK AND OPERATOR PLATFORM
EQN-351A	dated	Rev.	06-19-13	2 sheets	FAST LUBE OIL CHANGE SYSTEM
EQN-501	dated	Rev.	06-08-09	2 sheets	CENTRALIZED LUBE SYSTEM
EQN-552	dated	Rev.	05-29-13	1 sheet	MAX. TRAVEL HEIGHT
EQN-552-1	dated	Rev.	03-23-15	1 sheet	THREE POINTS OF CONTACT STICKER

The above referenced drawings shall become part of these specifications.

These drawings reflect the intent of the Department and any discrepancies shall be resolved at the line setting ticket meeting between the vendor and the Equipment Chief, or the pre-production inspection of the truck.

DRAWINGS APPEAR AT THE END OF THE SPECIFICATIONS.

SPECIFICATIONS
A-48-DB-C-AT

III. MANUALS:

The successful vendor shall furnish all applicable manuals per unit:

- 1 Operator's
- 1 Parts
- 1 Service
- 1 Engine
- 1 Transmission (Automatic or Manual)
- 1 Body and Sub-frame (Parts and Service)
- 1 Complete set of manuals for any additional items/equipment added to a piece of equipment.

The manuals listed shall be official O.E.M. publications supplemented with technical manuals for all components as published by sub-vendors/manufacturers.

Parts Manual presented must be a relative to "all" items utilized to build these units, with appropriate part numbers.

Delivery of these manuals shall be completed within a maximum of 90 days after the pilot model is accepted.

Manuals may be supplied on CD Disc in lieu of paper manuals.

SPECIFICATIONS
A-48-DB-C-AT

IV. TRAINING:

Mechanic:

The successful vendor shall provide services of qualified factory trained technicians for not more than 1 training sessions of not more than 7.5 hours at 1 PENNDOT locations to train personnel for in-depth preventive maintenance, overhaul and review of the proper usage of parts and service manuals, as well as component/system adjustments that need to be monitored at specified service intervals.

Operator:

The successful vendor shall provide services of qualified factory trained technicians for not more than 3 training sessions of not more than 22.5 hours at 1 PENNDOT locations to train personnel in the proper operation, safety and servicing of the equipment.

The successful vendor shall submit a training plan to the Fleet Management Division for approval within 45 days after receipt of the Purchase Order. The training plan shall consist of course outline and class schedule.

All training must be completed within 60 days after the dates established in the approved training plan unless an extension is mutually agreed to in writing by the Chief of the Fleet Management Division.

All training shall be coordinated with the District Equipment Managers, with the exception of Asphalt related training, which must be coordinated with the Statewide Training Coordinator (717) 787-4836, Fax (717) 783-4438.

SPECIFICATIONS
A-48-DB-C-AT

IV. WARRANTY: Per PCID No. 1075.

ENGINE WARRANTY:

The successful vendor and or supplying OEM shall provide the Department with a 100% parts and labor engine warranty FOR 60 months / 150,000 miles / 5,400 hours minimum. In addition to the engine warranty, the engine block shall be warranted against external perforation from corrosion for 60 months, 100% parts and labor.

NOTE: The oil pan shall be warranted against corrosion, rust, rust thru etc. regardless of atmospheric conditions for 60 months, 100% parts and labor.

EMISSION WARRANTY: The successful vendor and or supplying OEM shall provide the Department with a 100% parts and labor warranty for all emission related components to include the diesel particulate filter (DPF) FOR 60 months / 150,000 miles / 5,400 hours minimum. Shall be warranted against corrosion, rust, rust thru etc. regardless of atmospheric conditions.

RADIATOR WARRANTY:

Manufacturer service and warranty policy for radiator shall be for two (2) years, 100% parts and labor plus an additional three (3) years, 100% parts only.

TRANSMISSION WARRANTY:

Manufacturer service and warranty policy for automatic and manual transmissions shall be 60 months 100% parts and labor.

BODY ELECTRICAL/LIGHTING:

Wiring harness shall be 5 years 100% parts. First year shall include 100% labor.

All LED lights shall be 5 years 100% parts.

NOTE: WARRANTY REPAIRS SHALL BE COMPLETED AT THE MANUFACTURER'S LOCATION OR IN-HOUSE FIELD REPAIR COMPLETED BY PENNDOT. IT SHALL BE THE DEPARTMENTS DISCRETION TO REPAIR INTERNALLY OR TRANSPORT THE UNIT TO THE DEALERSHIP. THE MANUFACTURER SHALL REIMBURSE THE DEPARTMENT AT THE MANUFACTURERS STANDARD PUBLISHED IN-HOUSE LABOR RATE. THE LABOR RATE SHALL BE MUTUALLY AGREED UPON BETWEEN THE DEPARTMENT AND VENDOR/BIDDER. ALL IN-HOUSE WARRANTY DOCUMENTATION SHALL BE DELIVERED WITH THE PILOT MODEL. ALL WARRANTY DOCUMENTATION SHALL BE DELIVERED WITH THE PILOT MODEL.

SPECIFICATIONS
A-48-DB-C-AT

058500, 058700

LO-PRO CAB TANDEM TRUCK CHASSIS WITH OIL DISTRIBUTOR BODY

TRUCK, OIL DIST, 3K, LO-PRO CAB, ARC, AUTOMATIC (058500)

TRUCK, OIL DIST, 3K, LO-PRO CAB, ARC, MANUAL (058700)

INDEX

I. GENERAL TRUCK SPECIFICATIONS:

- A. Intent Statement
- B. Weight Distribution
- C. Power Train Overview
- D. Vehicle Components
 - 1. Axle-Front
 - 2. Axle-Rear, Tandem
 - 3. Brakes
 - 4. Cab
 - 5. Chassis
 - 6. Drive Line
 - 7. Electrical
 - 8. Engine
 - 9. Engine Accessories
 - 10. Exhaust
 - 11. Fast Lube Oil Change System (FLOCS)
 - 12. Frame and Frame Extension
 - 13. Instrumentation
 - 14. Light - Warning
 - 15. Paint
 - 16. Safety
 - 17. Steering
 - 18. Tank-Fuel
 - 19. Wheels/Tires
 - 20. Transmissions
 - 21. On-Board Grease System

SPECIFICATIONS
A-48-DB-C-AT

I. GENERAL TRUCK SPECIFICATIONS: (Continued)

E. OIL DISTRIBUTOR:

1. Alarm-Backup
2. Tank-Body-Installation
3. Cabinet, Tool Box
4. Calibration Control Console
5. Automatic Rate Control System
6. Air Controls
7. Circulation System
8. Decals and Signs (Tank)
9. Fenders (Tank)
10. Filter System
11. Fire Extinguishers
12. Flashing
13. Heating System
14. Hydrostatic Drive
15. Identification, Asphalt Tank
16. Insulation, Tank
17. Instruments and Accessories
18. Ladder, Tank
19. Manholes, Tank, & Strainer
20. Tank-Paint, Body
21. Tank, Piping
22. Platforms
23. Tank, Power-Take-Off
24. Pump, Asphalt Circulator System
25. Pump Flushing Line
26. Sump
27. Tank Inner Shell
28. Tank Outer Shell
29. Weight Distribution, Tank
30. Wiring and Lighting, Tank
31. Optional Heat Chase, Material Pump

II. DRAWINGS:

III. MANUALS:

IV. TRAINING:

V. WARRANTY:

SPECIFICATIONS
A-48-DB-C-AT

I. GENERAL TRUCK SPECIFICATIONS:

A. INTENT STATEMENT:

The purpose of these specifications is to describe a bituminous distributor for use by the Department to service road construction with bituminous materials. The vehicle shall consist of a cab, chassis, dual rear wheels and tandem rear-axle-drive, and be equipped with a tank and dispensing equipment as described.

Functions:

The distributor shall perform the following functions:

1. Fill tank by distributor pump from outside source.
2. Circulate material in tank.
3. Circulate material in spray bar.
4. Spray at a constant desired application rate, regardless of variance in truck speed and bar length.
5. Return material in spray bar to tank by pump suction.
6. Hand spray
7. Return material in hand spray to tank by pump suction.
8. Transfer from an outside source to another source without having material enter distributor tank.
9. Pump material back to supply source.
10. Heat material to proper temperature.

NOTE: Pennsylvania Department of General Services, PCID No. 1075, "*General Requirements for Bidding PENNDOT Vehicles/Equipment*", most current version effective at the time and date of bid opening, is included as a part of this specification. PCID No. 1075 may be reviewed and downloaded from the Department of General Services website, <http://www.dgs.state.pa.us>.

Delivery as required per Department of General Service PCID NO. 1075 Section "G". All units must be delivered within **270** days after receipt of the purchase order by the successful bidder.

B. WEIGHT DISTRIBUTION:

Engineering-certified weight distribution charts shall be provided with the pilot model for the equipment supplied.

It is understood that the components specified are minimum and if the truck manufacturer's Engineering Department recommends or deems necessary, due to their particular weight distribution, a larger component or a larger GAWR totally, the burden of responsibility is hereby placed upon the Manufacturer's Engineering Department to supply a unit that is totally engineered.

SPECIFICATIONS
A-48-DB-C-AT

I. GENERAL TRUCK SPECIFICATIONS: (Continued)

B. WEIGHT DISTRIBUTION: (Continued)

1. Frame
2. Axle
3. Tires
4. Steering unit of components
5. Rims
6. Suspension
7. Brakes
8. Any other items as required

The dynamic and static loads created by the unit, plus operational stresses, must be reviewed to ensure the Commonwealth of a properly designed/engineered unit.

Engineering Concurrence:

This specification and all specified components must be reviewed and approved by the successful manufacturer. The installation of the specified components must be approved by the successful manufacturer's Engineering Department.

Transmission gear (Manual or Automatic), and drive axle gear ratio selection shall be made to ensure an obtainable ground speed in the lowest useable gear of 3-5 MPH at 1300 RPM's for spraying applications. If a suitable ratio cannot be obtained, than an Eaton 1202 auxiliary transmission shall be used.

The distribution shall be made relative to the following information:

1. Payload of approximately 3,000 GAL minimum, of emulsion as permitted to provide a unit with the largest tank capacity best utilizing available GAWR's without exceeding maximum Pennsylvania GVWR.
2. Chassis fuel tank(s) and all other fluid tanks full.
3. 200 LB operator.

The vehicle shall be certified for 62,000 LB Gross Vehicle Weight Rating (GVWR). The GVWR shall be identified in the cab or on the door as the final complete certification label (minimum rating)

Actual Truck Weight

Slip requirements to be presented with the pilot model:

Chassis only	_____ <u>LB</u> Front Axle
	_____ <u>LB</u> Rear Axle
	_____ <u>LB</u> Total

SPECIFICATIONS
A-48-DB-C-AT

I. GENERAL TRUCK SPECIFICATIONS: (Continued)

B. WEIGHT DISTRIBUTION: (Continued)

"Chassis with body", if applicable, shall be split-weighed and total-weighed by a certified weight master and signed and presented with pilot model.

_____ LB Front Axle

_____ LB Rear Axle

_____ LB Total

Chassis with body and payload:

_____ LB Front Axle

_____ LB Rear Axle

_____ LB Total

Truck GAWR's as Built (LB)

Front GAWR

Rear GAWR

Axle _____

Tires _____

Truck GAWR's as Built (LB)

Springs_____

Rims_____

C. POWER TRAIN OVERVIEW:

NOTE: LUBRICANTS FOR FRONT AXLE HUBS AND DIFFERENTIALS, AUTOMATIC TRANSMISSION, TRANSFER CASES AND ALL REAR DIFFERENTIALS SHALL MEET OR EXCEED ALL APPROPRIATE MIL AND SAE SPECIFICATIONS FOR SYNTHETIC LUBRICANTS AND SHALL HAVE ALL PLUGS IDENTIFIED AS SYNTHETIC OR PAINTED RED.

(The OEM shall provide written exemption if synthetic oil is not installed).

SPECIFICATIONS
A-48-DB-C-AT

I. GENERAL TRUCK SPECIFICATIONS: (Continued)

C. POWER TRAIN OVERVIEW: (Continued)

ENGINE DIESEL -MIN. 10.8 LITER (actual engine liters), MINIMUM 365 HP AT GOVERNED RPM, MINIMUM 1340 LB FT TORQUE.

Transmission gear (Manual or Automatic), and drive axle gear ratio selection shall be made to ensure an obtainable ground speed in the lowest useable gear of 3-5 MPH at 1300 RPM's for spraying applications. If a suitable ratio cannot be obtained, than an Eaton 1202 auxiliary transmission shall be used.

CLUTCH & MANUAL TRANSMISSION:

Manually adjustable, Solo Clutch will not be accepted.

Cast Pressure plate, Stamped pressure plate will not be accepted. Dampened driven disc.

Externally lubricated and torque limiting with a clutch brake.

Clutch shall be capable of 100 ft/lb. above peak engine torque.

Clutch adjustment shall be set to specifications prior to delivery to the Department.

There shall be a neutral safety device to ensure that the vehicle cannot be started in gear.

Note: The transmission-input shaft shall be 2 inch spline.

EATON RTO – 16908LL

EATON RTO – 14908LL

AUTOMATIC TRANSMISSION:

AUTOMATIC ALLISION 4500 RDS 6 SPEED

REAR AXLE:

DANA DS463P

Meritor RT46-164-P

MACK S462 (46,000 LB with pump)

NOTE: All rear axles must provide axle shafts with a minimum diameter of 2.19 inch at the spline.

D. VEHICLE COMPONENTS:

1. AXLE-FRONT:

20,000 LB capacity "I"-beam type, minimum.

10,000 LB capacity at ground, each front spring, minimum.

The front axle grease fitting locations must be provided with zerks.

STEMCO oil seal assembly, including hub, plug type window and GUARDIAN seal, or approved equal.

Each unit shall have the front end aligned.

SPECIFICATIONS
A-48-DB-C-AT

I. GENERAL TRUCK SPECIFICATIONS: (Continued)

D. VEHICLE COMPONENTS: (Continued)

2. AXLE-REAR, TANDEM:

23,000 LB capacity at ground each rear spring.

Suspension tailored to axle loads and adequate to sustain maximum GVW without overload or permanent set.

Inter-axle differential (power divider), (in cab controls) with lockout and warning light with pump to lubricate inter-axle differential as furnished in EATON DS461-P, the pump system furnished in the ROCKWELL SSHD or the automatic inter-axle system furnished on the Mack S462.

STEMCO oil seal assembly, complete (GUARDIAN), or approved equal.

Magnetic drain plug.

The rear axle housings shall not be aluminum or lightweight component type.

Rear axle ratio selection will be made after the award and may be a mix of ratios as required. The successful vendor/manufacture shall present three (3) computer runs showing three (3) most likely ratios for consideration for a speed range up to 65 MPH max. This information shall be presented at the pre-build meeting.

3. BRAKES:

Braking System: Full air antilock in compliance with the most current FMVSS requirements.

The ABS shall incorporate a diagnostic fault switch that is capable of illuminating a fault light for diagnostic purposes. The switch shall be easily accessible and can be either dash or under-dash mounted. A dash-mounted display that will show all SAE message descriptions for the ABS is an acceptable means of diagnostics in lieu of the fault switch.

Rear brakes: 16.5 inch x 7 inch "S" cam with quick-change type single or double pin. (No substitute - standardization).

Drum brakes shall have automatic slack adjusters, clearance sensing with adjustment on application of the brake (no substitute).

Steer axle brake: 16.5 inch x 6 inch "S" cam or a power front disc brake system providing equal performance. Quick-change type single or double anchor pin if drum type brakes are furnished.

Backing plates on all drum brakes.

Air compressor: Per truck manufacturer's recommendation. Buzzer-type, low air pressure indicator. Compressor shall be fitted with a safety valve to prevent mechanical failure.

Parking brake: Rear wheels, spring-type, MGM 30/30 or ANCHORLOCK 30/30 gold seal chambers (no substitute). Parking brake shall provide modulated emergency braking via the foot valve in the event of a rear service system failure.

Air tank: Automatic drain valve, with heater on wet (first) tank. Each of the remaining air tanks shall have a manual drain valve.

Air dryer: With heater and coalescing filter mounted away from road splashing and a minimum of 20 inches above road surface. Dryer shall be compatible with the body company clearance requirements for sub-frame, valve body, etc. Ref: Meritor/ Wabco installation made in concurrence with the air compressor manufacturer's recommendations.

Air dryer shall be placed to accommodate the changing of filter cartridges without disconnecting any hoses or removing dryer base from its mounting location. Final mounting location shall be determined at Pre Build meeting. All electrical connectors for drain valve and air dryer shall be covered with heat-shrink material or have sealed connections.

System shall be equipped with anti-compounding to prevent mechanical failure of the foundation brakes, slack adjusters, etc.

SPECIFICATIONS
A-48-DB-C-AT

I. GENERAL TRUCK SPECIFICATIONS: (Continued)

D. VEHICLE COMPONENTS: (Continued)

4. CAB:

Aluminum or galvanized steel cab.

Cab-over/lo-profile.

Fenders: Front fenders shall have extensions to cover the width of the front tires.

Air Conditioning: Manufacturer's STD highest output.

Cruise Control

AM/FM radio

Seats: Driver's seat shall be BOSTROM Air 905 Series with lumbar support, National 195 Series with lumbar or DuraForm Air Command Series (fabri form cushions with lumbar support), with body cloth and retractable seat belt. **(Seatbelt shall be High Visibility Orange)**. A bellow-type or protective skirt shall cover the seat suspension mechanism. **(No substitute, standardization)**. Color coordinated to cab interior

Passenger seat: With three-point retractable seat belt **(Seatbelt shall be High Visibility Orange)**, manufacturer's standard non-suspension (static) high-back type. Color coordinated.

Deluxe fresh air hot water heater and defroster manufacturer's highest output.

Windshield: One (1) or two (2) piece construction, tinted. Safety glass throughout.

Dual inside sun visors.

Dual windshield Wipers, shall be minimum 2-speed electric with intermittent feature.

Heaviest Wipers, arms, motor and linkages available. Washer system shall be electric. Minimum capacity of two (2) quarts of washer fluid and shall be filled with an anti-freeze type solvent.

Drivers and passenger side windows shall be manual.

Mirrors: Driver's and passenger side power mirrors, west coast style minimum 6 inch X 16 inch manufacturer's standard heavy duty break away arms.

Mirrors shall be heated with a lighted toggle switch mounted within accessible reach of the operator, automatic on/off is acceptable. The wires shall be fitted in such a way that the mirror glass/element can be changed by unplugging the two-wire lead.

There shall be a heated convex mirror both sides, minimum 5.5 inch X 8.8 inch or 8" diameter.

Drivers and passenger cab entrance steps: Shall be aluminum, serrated. The outer step edge must be serrated in lieu of plain. (Overlay is not acceptable).

Step design material must be the same both left and right side.

Ref: Bustin No. NST4 full size, Ohio Grating No. JA21195G4 serrated, IKG. Industries Type B54 or Mack.

Top of the first step shall be approximately 21 inches above the ground.

SPECIFICATIONS
A-48-DB-C-AT

I. GENERAL TRUCK SPECIFICATIONS: (Continued)

D. VEHICLE COMPONENTS: (Continued)

4. CAB: (Continued)

Grab handles shall be supplied on all cab entry locations. Three points of contact shall be achievable at all cab entry locations. Handrails shall be coated with non-skid paint (non-skid tape is unacceptable) or have OEM anti-slip rubber inserts, both non-skid paint or rubber inserts must extend the full length of the grab handle.

Exterior grab handles shall be supplied if available from OEM.

There shall be a permanent decal, 2 inch high red letters on white back ground affixed by the driver side door handle stating the overall maximum travel height of the completed and unloaded unit.

(Example) HT-__' __" Ref. EQN-552

There shall be a permanent decal, "Three Point Contact" located at each entry point of the truck cab and at the bed ladder area per EQN – 552-1. Exact location to be determined at pre build meeting.

Driver armrest. Seat shall have a fold-up armrest on the right side of the driver's seat.

Air horn(s): With protective cover(s).

All controls and knobs shall be properly identified.

The cab floor covering shall be heavy-duty rubber with closed cell rubber or heavy felt backing.

5. CHASSIS:

62,000 LB GVWR minimum, manufacturer's rating.

Cab Axle (CA) dimension: Wheel Base (WB) and CA dimension to be determined and adjusted by the manufacturer to provide the optimum legal weight distributions with maximum payload.

Front Bumper: Heavy duty. To accommodate an 8 inch wide flat sign, mounted flush.

Front mounted tow hooks or eyes: Two (2) front or one (1) severe-duty centered.

6. DRIVE LINE:

Main driveline: Spicer Life XL or Meritor MXL Series. "**Factory balanced**" greasable, (one zerk minimum). Heavy-duty driveline shall be engineered and be compatible to engine, drive train and transmission torque. Heavy-duty center bearing, if required, with due consideration to drive shaft angles, length, location, proper bolting based upon engine and transmission selection. Inter-axle driveline: Spicer Life XL or Meritor MXL Series.

SPECIFICATIONS
A-48-DB-C-AT

I. GENERAL TRUCK SPECIFICATION: (Continued)

D. VEHICLE COMPONENTS: (Continued)

7. ELECTRICAL:

All copper system, negative ground.

Battery location to be determined at the pre-build meeting.

Batteries: Three (3) heavy-duty, 12-volts, maintenance-free, BCI Group Size 31, with stud-type posts and anti-corrosion treatment on each terminal. 2500 total cold cranking amperes (CCA) min.

Battery Mounting: It shall include the following:

- a.) 0.25 inch thick rubber shock pad under the battery.
- b.) Box with cover. Cover shall be constructed of fiberglass, poly, or aluminum (if aluminum, there shall be an insulating liner). **Mounting of accessories within the battery box is unacceptable. All fuses and circuit breaker shall be labeled.**
- c.) Mounting bolts grade-8 with self-locking nuts.

Cables shall conform to RCC Practice 105 "sealed" terminal ends for stud-type battery posts.

Electrical system: Circuit-breaker-equipped, in easily accessible location, weatherproof. Fuses acceptable in circuit so identified by manufacturer as safety factor. Any fuse or circuit breaker liable to be damaged during truck operation shall have an easily removable protective cover. All connections shall be made using sealed connections and dielectric grease.

Alternator: Delco 36SI (No substitute, Standardization) 160 A minimum, high performance, solid state (brushless).

Starter motor: Delco 39 MT (No Substitute, Standardization) with thermal over-crank protection and high torque capacity. Suitable for the diesel engines offered as per starter manufacturer's recommendation.

Note: Starter shall have (OCP) either built in or controlled by the Vehicle's control system, (if required)

Battery cable from battery negative terminal to the truck frame and from the battery or frame to the starter motor.

Alternator and starter mounting bolts: Grade 8.

Power supply for two-way radio: Quantity (1). Dash mounted. Both male/female ends shall be supplied, Ref: EQN-78.

GPS Combo Radio Antenna: There shall be a pedestal mount base with built-in GPS, PCTEL model GPPB-204-54-12-S1-M1 and a low profile black antenna, PCTEL model BMLPU700. Assembly shall be mounted on pedestal with mini light bar, with the antenna cable routed to the front dash area between the seats towards windshield. There shall be a minimum of 1 feet of antenna cable coiled at the base of the dash to allow for connection to department radio. Antenna shall be prewired with a MINI - UHF MALE connection. (No substitute, standardization). No mounting in roof. REF. EQN-120Q

Power Distribution Center: There shall be a 4-way power/ground distribution center located on the underside of the dash for connection of department state radio. The lugs shall be configured in the following manner: (1) lug shall be a 30 ampere constant hot circuit, (1) lug shall be a 10 ampere ignition controlled circuit. (2) lugs shall be chassis ground. All connections shall be enclosed in a weatherproof enclosure.

Electrical wiring: Chassis wiring harness protected at areas prone to cause chafing by installing convoluted plastic conduit and clamped using steel band clamps with rubber inserts.

All pass-through points shall be properly sealed and protected.

Flasher: (All) heavy-duty electrical, Ref: Tridon Model EL 12 or equal.

Note: If an audible alarm is supplied for 4 ways and turn signals, it shall have an on/off capability.

SPECIFICATIONS
A-48-DB-C-AT

I. GENERAL TRUCK SPECIFICATIONS: (Continued)

D. VEHICLE COMPONENTS: (Continued)

8. ENGINE:

Replaceable heavy-duty full flow type fuel filter(s) and oil filter(s) as recommended by the engine manufacturer. **And bearing a legible OEM part number.**

Cooling system: The largest factory available capacity compatible with engines and transmissions referenced and for continuous high engine output under extreme temperatures and/or operations conditions due to prolonged slow ground speeds while applying the asphalt material. With overflow recovery system and visual level indicator.

Radiator core and shell: Shall be manufacturer's heaviest construction grade radiator available, with overflow recovery system and visual level indicator.

9. ENGINE ACCESSORIES:

Automatic idle shutdown shall be set to five (5) minutes. An audible warning alarm shall be provided to alert operator prior to engine shutting down.

Automatic idle shutdown shall be programmed to be overridden when the PTO Mode is engaged.

ECM shall be set to a maximum of sixty five (65) miles per hour.

Engine Heater: Immersion in-block type, for cooling system, with waterproof plug flush-mounted in an accessible location at the front/roadside of the vehicle, outside the cab/hood, 115 volt, 3-prong plug. The electrical cable from the heater to plug shall be one piece and waterproof.

Coolant filter: A non-charged spin-on coolant filter shall be installed only if required by engine manufacturer.

Air Cleaner: Heavy Duty Capacity adequate for maximum performance of the engine.

Fan: Thermostatically controlled, viscous type.

Screening system: Mounted behind radiator grille that protects radiator from stones and bugs. System to be approved by engine and truck manufacturer(s).

Diesel Fuel Filter: There shall be a DAVCO 382 or a 482 filtration unit installed and mounted (Higher than fuel tank) per manufactures recommendations in a location to accommodate filter replacements, yet be protected from road debris **(No substitute, standardization)**.

Mounting location to be determined at pre-build meeting.

Davco 382 Unit shall be equipped with engine coolant heat and 120 volt heater circuit. The 120 volt circuit and engine block heater shall be powered via the same electrical connection. **(No substitute, standardization)**

Davco 482 shall be equipped with a 12 volt and 120 volt heater circuit. 12 volt heater circuit will activate with the ignition key switch, the 120 volt heater circuit and engine block heater shall be powered via the same electrical connection. **(No substitute, standardization)**. Air restriction gauge: Flush, dash-mounted with indicator slide for engine air cleaner, RE: FILTER MINDER, manufactured by Engineered Products Company, or prior-approved equal.

Governor: Set at manufacturer's recommended maximum engine speed (rpm).

Lubricating oil lines: High quality flexible wire braid type, "AEROQUIP" or approved equal system, minimum standard if hoses are used.

Engine Brake: Engine shall be equipped with a minimum 2 stage, full engine compression brake. Brake lights shall activate when engine brake is activated Ref: Jacobs.

SPECIFICATIONS
A-48-DB-C-AT

I. GENEAL TRUCK SPECIFICATIONS: (Continued)

D. VEHICLE COMPONENTS: (Continued)

10. EXHAUST:

DPF (diesel particulate filter) and exhaust system shall meet the latest EPA emission requirements. Vertical tailpipe with elbow and muffler system or approved horizontal muffler and vertical tail pipe with elbow. Exhaust system shall not be close to any fluid tank or any hoses. The DPF, muffler and tail pipe shall be shielded or insulated to protect personnel from burns when entering or exiting the cab. The shield shall be 180 degrees to 360 degrees and shall be of non-rustable material such as stainless steel or aluminum. RE: RIKER or equal.

11. FAST LUBE OIL CHANGE SYSTEM (FLOCS):

This FLOCS system shall be installed with all fittings, brackets, clamps and hoses. Hose from oil pan to FLOCS fitting shall be hydraulic hose with a 100R2 rating and properly secured. The system shall be compatible with all fittings presently used by the Department. The final placement of the male half of the snap coupler, on the equipment, shall be determined at the pre-build meeting. Ref: EQN-351A.

12. FRAME:

Resisting Bending Moment (RBM): Minimum of 2,800,000 inch LB per rail at high-stress areas and 2,086,000 inch LB at non-high-stress areas, for the entire length of the frame, and any frame reinforcements. Minimum frame RBM shall be approved by manufacturer's Engineering Department.

Frame material: Heat treated carbon steel, at least 110,000 psi yield strength.

Main frame and any required liners: Either straight channel or offset channel, full length. Drop frames are not acceptable. Minimum 96 inch deep section.

Frame AF extension: An integral and continuous extension of the main-frame side rail section modulus. Bolt on or welded extensions are acceptable. Length sufficient to properly mount body and equipment.

13. INSTRUMENTATION:

All instruments illuminated and dash-mounted except where specified otherwise. All standard instruments shall be supplied, including, but not limited to the following:

Gauges: Oil pressure gauge: with warning light or audible alarm.

Air pressure: gauge(s) for dual circuit, dual indicator with low pressure audible alarm.

Inlet manifold pressure.

Coolant temperature: with warning light or audible alarm.

Transmission oil temperature: for automatic transmission only, with warning light or audible alarm.

Fuel gauge

Hourmeter that records only when the engine is running. Ref: DATCON or equal.

Speedometer with odometer.

Tachometer for engine and power-take-off.

Voltmeter

Parking brake indicator light.

SPECIFICATIONS
A-48-DB-C-AT

I. GENEAL TRUCK SPECIFICATIONS: (Continued)

D. VEHICLE COMPONENTS: (Continued)

14. LIGHT - WARNING:

All lights shall meet all Federal and State regulations. The head Lights shall be Halogen with (DRL's) daytime running lights. Factory or aftermarket installation. Body lights shall have their own dedicated complete circuit. All lights including the body shall be LED.

Whelen Light Kit Part # PADOTSY8, Kit contains the following lighting. EQN – 120Q

1 - R10PADOT Light Bar to be pedestal mounted on the top driver's side, front of body. In no case shall the light bar be mounted on the roof of the vehicle.

2 - M6AD Amber warning lights with brush guard mounted to the rear of body

2 - M6BTDD Stop, Tail, Turn lights with brush guard

2 - M6BUD Back-up lights with brush guards

4- LINZ6AD Amber warning lights, grommet mounted, flush mounted 1 to each side (middle/center) of bed and 2 flush mounted and equally spaced in the front grill per EQN – 120Q. Warning lights are to be wired in conjunction with above light bar. 4 - LINZ6 Grommet Kits

10 - W441D Harness side mating Deutsch connectors.

The above lights are supplied with male and female Deutsch connectors that shall be utilized to connect the vendor supplied harness to each light source.

There shall be a Truck-Lite Model# 36140C LED license plate light with light bracket PN# 36710 (Installed). Body builder to supply remaining marker and ICC lighting, they shall be protected against damage and shall also be shock mounted. Connections shall be water tight.

The Warning lights / Light bar shall have a lighted, permanently labeled toggle switch located in the dash. Body wiring shall be Grote, Trucklite, or Prior Approved Equal.

There shall be no splices outside of a sealed box or fixture.

A color-coded electrical wiring chart and schematic shall accompany each body.

15. PAINT:

Cab shall be painted PennDOT yellow Ref: DuPont F9885, PPG 85246, Sherwin Williams 73266, Sikkens 4017 or NAPA 73266 for shade only. Frame and all underside components shall be painted black. Front bumper and frame shall be primed and painted black (with hardener) low VOC. All bare metal surfaces shall be coated using etching primer prior to paint. All surfaces shall be properly cleaned and prepared prior to paint, with all weld splatter and debris removed.

All tank components that are not polished aluminum or stainless shall be painted black.

16. SAFETY:

Cab shall have reflective enhancement per EQN-127A.

Anti-slip paint is required on all handholds, for the entire length, (tape is unacceptable). All handrails, ladders, and step configurations shall be built for three points of contact.

There shall be two wheel chocks per truck Ref: buyers WC1467 or equal with a rope. Mounting location will be determined at pre-build meeting.

All corners shall be angled or rounded for safety.

There shall be a triangle warning kit mounted in the cab.

Fire extinguishers 3A:40BC 5lb. rechargeable with vehicle mount. Mounted in the cab for easy and quick access. Ref: 3A:40BC (5 LB).

Ref: EQN-66A, EQN-82.

SPECIFICATIONS
A-48-DB-C-AT

I. GENERAL TRUCK SPECIFICATIONS: (Continued)

D. VEHICLE COMPONENTS: (Continued)

16. SAFETY: (Continued)

There shall be a permanent decal, 2 inch high red letters on white back ground affixed by the driver side door handle stating the overall maximum travel height of the completed and unloaded unit.
(Example) HT-__' __" Ref. EQN-552.

There shall be a permanent decal, "Three Point Contact" located at each entry point of the truck cab and at the bed ladder area per EQN – 552-1. Exact location to be determined at pre build meeting.

17. STEERING:

Power steering: Dual-integral or single-integral type hydraulic

Steering system (e.g. flow, pressure, relief valve etc.) shall be selected considering the full front axle loading. Ref. ROSS, SHEPPARD or TRW gear assembly.

Hydraulic supply pump: Vane type or roller type, with sufficient oil flow to permit one (1) steering wheel revolution per second with front axle loaded to capacity, in a "park" condition. Ref: VICKERS V-20, EATON or BORG WARNER. The pump shall not be the integral filter type unit.

Power Steering Reservoir: "Remote-mounted", and factory-mounted, minimum two (2) quart capacity, incorporating a filter, which is easy to remove and replace.

Steering wheel diameter shall be 18 inch (approx). Manufactures' Standard.

Glidcoast steering shaft, Bendix wedge lock lube-for-life shaft or ZF type steering shaft.

18. TANK - FUEL:

Safety - type fuel tank as per the requirements of FMVSS. **Dual tanks are unacceptable.**

One (1) 80 GAL minimum total capacity, frame mounted. (Mounted drivers side)

Cylindrical. Aluminum or stainless steel, unpainted. (Conventional Only).

Heavy-duty mounting 2 inch wide stainless steel straps with rubber shims/liners.

Tank mounting hardware and brackets shall be for "severe duty" applications.

Accessible fill pipe, (located at either end of tank to avoid interference with steps).

SPECIFICATIONS
A-48-DB-C-AT

I. GENERAL TRUCK SPECIFICATIONS: (Continued)

D. VEHICLE COMPONENTS: (Continued)

19. WHEELS/TIRES:

The truck shall be equipped with hub piloted steel disc wheels for tubeless tires. The wheel end shall be equipped with outboard cast brake drums, and 15 degree tubeless steel wheels, hub piloted, 10 hole - 285.75mm bolt circle with 22mm two-piece flange nuts.

Front: Wheels: 22.5 x 12.25, 10 hole - 285.75mm bolt circle with 220mm bore, tubeless steel disc wheel rated at 10,500 LBS at a maximum inflation pressure of 120 PSIG. Accuride part number 29806 or 29807. **(No substitute, standardization).**

Rear: Wheels: 22.5 x 8.25, 10 hole - 285.75mm bolt circle with 220mm bore, tubeless steel disc wheel rated at 7,500 LBS at a maximum inflation pressure of 120 PSIG. Accuride part number 28828 or 29169. **(No substitute, standardization).**

The dual rear wheel/tire assembly shall have clearance between the tires, which permits the use of dual tire chains.

Wheel-Guard Separators: The wheel ends shall be equipped with the Accuride part number 5903 Wheel Guard Separator as follows:

Front axle - between the wheel and the brake drum.

Rear axle - between the inner dual and the brake drum and between the inner and outerduals

Paint: The wheels shall be topcoat painted with TGIC Polyester Powder Paint MLD-82008 High Gloss Gray or equal applied over Cathodic Electro-Disposition Gray Primer.

Tires: All tires shall be radials.

Front Tires: 425/65R22.5 (Load Range L).

Rear Tires: 12R22.5H (Load Range H).

MANUFACTURER

Goodyear

Michelin

Bridgestone

FRONT TIRE

G-296

XZY3

M854

REAR TIRE

G-282 MSD / G-622 RSD

XDN-2

L320

SPECIFICATIONS
A-48-DB-C-AT

I. GENERAL TRUCK SPECIFICATIONS: (Continued)

D. VEHICLE COMPONENTS: (Continued)

20. TRANSMISSION

Oil cooler for transmission required due to prolonged transmission torque converter operation in low gears. Cooler size must be provided to keep the transmission fluid at an acceptable operating temperature under these prolonged conditions. (Water-to-oil type cooler.) An Allison approved cooling system shall be installed regardless of whether retarder is incorporated in the system or not. Automatic transmission cooler lines shall be stainless steel or a **preapproved** no-rusting material.

NOTE: All vehicles shall have a clutch-operated or transmission-operated safety starting switch. Transmission gear, and drive axle gear ratio selection shall be made to ensure an obtainable ground speed in the lowest useable gear of 3-5 MPH at 1300 RPM's for spraying applications. If a suitable ratio cannot be obtained, than an Eaton 1202 auxiliary transmission shall be used.

21. ON BOARD GREASE SYSTEM

There shall be a centralized on board chassis lubrication system installed. Ref: EQN-501.

SPECIFICATIONS
A-48-DB-C-AT

I. GENERAL TRUCK SPECIFICATIONS: (Continued)

E. OIL DISTRIBUTOR:

The design of the tank and its equipment shall meet regulations of the United States Department of Transportation, Hazardous Substances Transportation Board, for asphaltic materials having a flash point of 100 degrees F or higher and shall comply with the Federal Motor Carrier Safety Regulations title no. 49, as applicable.

1. ALARM - BACKUP:

Ecco Model 450, shock mounted.

2. TANK - BODY - INSTALLATION:

It shall be the responsibility of the successful vendor to have this tank mounted on the specified chassis.

The installation shall be engineered and approved by the vehicle manufacturer

Tank Mounting: The tank mounting shall be as low as possible

Tank Gauge: Float type with dial calibrated in 50-GAL increments, located in ground positioned to allow unobstructed visibility.

Measuring Stick: Steel or aluminum, calibrated in 50-GAL increments. Designed and calibrated to read tank contents.

Any tank-mounted accessory required shall be mounted on a pad which is welded to the tank in lieu of welding the accessory directly to the tank. E.g. steps, catwalk, etc.

All mounting brackets attached to the truck body shall be stainless steel and shock mounted.

3. CABINET, TOOL BOX:

Stainless steel hinges.

Drip edge over top of doors, plus 3 inch overhang on both sides of door.

Watertight doors-gaskets required.

Key-locked, with matching keys.

Installation on frame rail, or supported by skirting and tank shell, size as permitted.

Corrugated rubber matting to facilitate full shelf size

4. CALIBRATION CONTROL CONSOLE:

The truck cab-mounted console shall provided the following functions and controls properly identified:

- a. Spray-bar on-and-off switch with controls in cab and at rear operator platform, or only in the cab.
- b. Electronic sensing device (no substitute, mechanical unacceptable).
- c. High and low level bitumen indicator light and an alarm audible from the front or rear of unit.
- d. High temperature hydraulic oil warning light.
- e. Variable-displacement hydrostatic pump control.
- f. Control to increase pump speed for loading and unloading.
- g. Front and or rear suction devices, air or electric over air operated.

SPECIFICATIONS
A-48-DB-C-AT

I. GENERAL TRUCK SPECIFICATIONS: (Continued)

E. OIL DISTRIBUTOR: (Continued)

5. AUTOMATIC RATE CONTROL SYSTEM:

This system will be capable of the following as a minimum.

- a. Fully cab-controlled.
- b. Wing lift and lower (also rear control).
- c. Bar lift and lower (also rear control).
- d. Bar side shift, 26 inch overall, 13 inch from center. Also rear control.
- e. Spray width controlled in increments of minimum 12 inch maximum 24 inch on Main Bar and 12 inch on wings.
- f. Solvent injection system to clean bar and outside of unit. (Front or rear control).
- g. Fully self-adjusting mechanism to control application rate regardless of spray bar width and ground speed (if specified as automatic rate control).
- h. System will be capable of loading and unloading with full pump capacity and still retain preset rate selection (if specified as automatic rate control).
- i. All digital readout gauges, gallons per mm and feet per minute.

6. AIR CONTROLS:

Distributor shall be equipped with driver-operated air controls. Air for the controls shall be obtained from the air system on the truck chassis. The distributor air system shall include its own air reservoir (using truck chassis reservoir not acceptable) with check valve set at 80 PSI to prevent loss of air on truck chassis brakes in case lines are ruptured. Truck manufacturer's engineering concurrence required. Relief valve on tank air system shall be set at 80 PSI. System shall have its own air line oiling device.

7. CIRCULATION SYSTEM:

Quick-connecting coupler for attaching loading hose to distributor fill and discharge lines shall be provided.

Strainer in filling line.

Filling line shall be above the intake valve.

Pump discharge or suction strainer shall be provided to keep foreign matter from plugging nozzles, easily removed for cleaning.

Internal fill line with anti-siphoning dome or closing valve to prevent material from flowing into pump when tank is full.

The circulating system to spray bar shall be constructed using steel piping and/or ball joints and/or flexible lines using high pressure rubber or steel hose for flexibility and "optimum safety" due to potential high temperature material.

SPECIFICATIONS
A-48-DB-C-AT

I. GENERAL TRUCK SPECIFICATIONS: (Continued)

E. OIL DISTRIBUTOR: (Continued)

7. CIRCULATION SYSTEM: (Continued)

a. Spray Bar:

- i. Type: Full-circulating, shut-off at nozzle, 16 feet minimum in length, hinged or retractable for traveling. Length of bar in folded position not to exceed 8 feet. Bar shall be air operated or hydraulic operated to shift bar 26 inches and raise for traveling.
- ii. Spray bar valves: There shall be an individual valve and quick disconnect for each individual valve.
- iii. Nozzles: Spaced on 4 inch centers on spray bar. A complete set of brass slotted non-clogging nozzles to be provided on the machine as defined below.
- iv. Relieving leak-proof sections on each side of spray bar shall allow bar ends to bend backward or forward if an obstruction is hit.
- v. Cutoff switch on wing that prevents accidental spraying when wings are raised.

Each unit shall be fitted with one complete set of emulsion nozzles AC-20 and two (2) end nozzles. The spray bar shall consist of 16 ft of spray bar.

b. Hand Spray Unit:

Each unit shall be furnished with a steel reinforced rubber hand spray hose, 25 feet x 1 inch (ID) with a steel or aluminum hand spray gun with cold handle and 2 spray nozzles. An on and off control valve shall be provided.

A means must be provided to clean out the hand gun and hose assembly, and to suck back the material left in the hose assembly and hand gun.

8. DECALS AND SIGNS (TANK):

The tank shall have all necessary appropriate material warning decals on all sides mounted in unobstructed view to alert near-by personnel of tank contents and operational hazards as required by Federal and State Standards.

Appropriate placards shall be provided as per 49CFR.

SPECIFICATIONS
A-48-DB-C-AT

I. GENERAL TRUCK SPECIFICATIONS: (Continued)

E. OIL DISTRIBUTOR: (Continued)

9. FENDERS (TANK):

Bolted fenders or catwalk/fender, removable type.

Tank fenders shall be full, flanged type using 0.080 inch aluminum or mild steel construction, or catwalk and integral steel fender assembly.

Mud flaps front and rear of rear wheel, fenders to meet Motor Vehicles Code. Rear mud flaps, 6 inch off-deck

NOTE: If skirting incorporates the fenders design, disregard these fender requirements.

There shall be full width back-flap/mg fabricated from black 0.2500 inch rubber. (Final location shall be made at the pre-build meeting.)

10. FILTER SYSTEM:

The tank pump shall be protected by means of strainer to eliminate foreign material entry. The strainer shall be easily accessible for cleaning.

11. FIRE EXTINGUISHERS:

Shall comply with NFPA Standard No. 385, and General Regulations governing the Highway Transportation of Hazardous Substance and Federal Motor Carrier Safety Regulations, Title 49.

Two (2) rechargeable 10 LB dry chemical 20BC-rated fire extinguishers with charge condition indicator and red waterproof snap-on covers. One (1) extinguisher mounted at right front side of the tank and one (1) mounted at the front of the tank on the driver's side near the cab.

12. FLASHING:

The tank shall have gutter type flashing for hose support including brackets on the right or left side to store the fill hose.

13. HEATING SYSTEM:

a. FLUE:

One (1) 0.172 inch (8 gauge) to 0.125 inch (11 gauge) U-type minimum 6 inch steel flue, located below center of tank for fast heating of load and heating of small amounts of material. Flue welded to flanged openings in tank rear head and supported by sleeves in surge plates to prevent wear and allow for expansion. Stainless steel external exhaust stack with hinged cover and stainless steel hinge pin to prevent heat loss, or a system approved by manufacturer's engineering department. Flue exhaust opening on right or left side of tank away from operator. The inlet and exhaust opening of the flue shall be in the same horizontal plane, allowing heating with a minimum of material in the tank. Flue shall run the full length of the tank. Exhaust shall not be directed at any component.

SPECIFICATIONS
A-48-DB-C-AT

I. GENERAL TRUCK SPECIFICATIONS: (Continued)

E. OIL DISTRIBUTOR: (Continued)

13. HEATING SYSTEM: (Continued)

b. BURNER:

One (1), minimum, oil-fired atomizing-type with minimum capacity of 935,000 Btu per hour burner with pressure regulator, valves, piping, blower, flue liner, fuel pump, with solid state electronic ignition.

14. HYDROSTATIC DRIVE:

Note: Automatic transmission driven PTO

Manual transmission engine driven PTO.

- a. Variable displacement hydraulic pump.
- b. Hydrostatic motor.
- c. Type: Hydrostatic transmission.

NOTE: Hydraulic oil may reach temperatures up to 200 degrees F without damage to the unit.

Unit shall have internal valving, and shall be fitted with relief valve and high oil temperature signal in cab.

- d. Flywheel Type full time live power.
- e. Hydraulic Lines:

- i. High-pressure hose with swaged type split flange "O" ring fittings as per SAE standards.
 - ii. Low-pressure hose installation shall be made according to transmission manufacturer's recommendation. Only top quality fittings, tubing and hoses to be used.
- f. Controls: Micro-control of hydrostatic transmission for setting asphalt pump discharge rate shall be located in truck cab. Control to permit stopping the variable pump discharge without disconnecting the drive and be equipped with an override of the micro-control which shall allow increases in asphalt pump output for filling, sucking back, etc., without affecting application rate setting. (Only applicable if automatic rate control specified).

15. IDENTIFICATION, ASPHALT TANK:

The gallon capacity shall be shown as:

- a. Maximum capacity - gallons/liters
- b. Legal capacity - pounds of payload

A heavy metal tag, minimum 0.063 inch (16 gauge) steel or aluminum identifying the above information shall be attached.

SPECIFICATIONS
A-48-DB-C-AT

I. GENERAL TRUCK SPECIFICATIONS: (Continued)

E. OIL DISTRIBUTOR: (Continued)

16. INSULATION, TANK:

The thermal insulation between the inner shell and outer jacket, including bulkhead, shall be a minimum of 2 inch fiberglass or mineral wool with a density of 1 LB per cubic foot. The insulation shall be installed and bound to prevent shifting or sagging. (Vendor shall verify insulation compliance's). Spacers shall be furnished to prevent insulation compression and collapse.

17. INSTRUMENTS AND ACCESSORIES:

a. Thermometers:

- i. A 2 inch minimum dial size, dial type, 50 degrees F to 500 degrees F. REF: WEISS or equal.
- ii. A steel-armored and engraved pencil type thermometer shall be located next to the dial thermometer in a blind well.

b. Loading Hose:

Each unit shall be furnished with a 3 inch x 15 feet steel flexible loading hose with male threaded ends and vendor's quick couplers.

c. Hydraulic Hose Clamping:

Ref: EQN 94. HYCON or equal clamps, as required.

18. LADDER, TANK:

Full length ladder, 12 inch step increments and 16 inch wide. First step height approximately 12 inch to 16 inch above ground level. A folding step shall be used below the ICC bumper with the ability to be locked in the up position during operation or transportation, with step in the folder position it shall provide the same clearance as the ICC bumper.

There shall be a permanent decal, "Three Point Contact" located at each entry point of the truck cab and at the bed ladder area per EQN – 552-1. Exact location to be determined at pre build meeting.

1 inch minimum OD tubular handrails. Ladder reinforcements shall be dual and sturdy in design.

Ladder location shall be determined at the pre-build meeting.

Steps/ladders shall be serrated swage lock with end band steel or aluminum. (Overlay is unacceptable)

The outer step edge must be serrated in lieu of plain, smooth metal edge.

All edges must be banded on the outer perimeter.

Steps/ladders design and material shall be the same design and material on the left and right side of the equipment if applicable.

Referenced acceptable material – Bustin NST4, Ohio Grating JA2119SG4 or IKG Industries BS4.

Landing/s and or catwalks shall be furnished using plain non-serrated safety grating, manufacturer's standard according to tank configuration.

SPECIFICATIONS
A-48-DB-C-AT

I. GENERAL TRUCK SPECIFICATIONS: (Continued)

E. OIL DISTRIBUTION: (Continued)

19. MANHOLES, TANK & STRAINER:

a. Manholes:

18 inch to 20 inch minimum, non-relieving type manholes, in accordance with the most current Federal guidelines. Cover shall be furnished with woven-wire impregnated composition gaskets. Cover shall be hinged and quick-opening type.

b. Strainer:

Strainer removable type designed to fit inside the above manhole.

c. Spillage Collar:

Circular or rectangular collar around manhole with 3 inch internal drain with expansion joint to catch any excessive material overflow while loading, and shall drain excess material onto the ground.

20. TANK-PAINT, BODY:

Anti-slip paint is required on all handholds, for the entire length, (tape is unacceptable). All handrails, ladders, and step configurations shall be built for three points of contact.

Grab handles shall be supplied on all cab entry locations. Three points of contact shall be achievable at all cab entry locations. Handrails shall be coated with non-skid paint (non-skid tape is unacceptable) or have OEM anti-slip rubber inserts, both non-skid paint or rubber inserts must extend the full length of the grab handle

All non-aluminum parts shall be primed and painted black.

The tank body shall have conspicuity tape on left and right side, full length Ref: EQN-127.

Under no circumstances shall the aluminum skin be painted.

21. TANK, PIPING:

The tank plumbing shall incorporate a Department-approved sampling valve.

SPECIFICATIONS
A-48-DB-C-AT

I. GENERAL TRUCK SPECIFICATIONS: (Continued)

E. OIL DISTRIBUTOR: (Continued)

22. PLATFORMS: Ref: EQN-231

a. Tank Top:

A minimum of 54 inch x 54 inch square manhole platform, or 32 inch x 32 inch spill-box assembly (total overall).

b. Operator Station:

Operator platform to provide access to all rear distributor controls, if required.
Adequate hand rails for operator safety and proper entry and exit locations.
All sensor wiring shall be protected by piping and easily removable for service.
If all controls are accessible from ground level, additional platform is not necessary.

23. TANK, POWER-TAKE-OFF:

Extending the bumper forward to accommodate a pump that is placed forward of the bonnet (hood) is unacceptable.

24. PUMP, ASPHALT CIRCULATOR SYSTEM:

Pump: Positive displacement type, minimum capacity 400 GPM. Located to provide a constant head pressure in order to eliminate pump cavitation.

Tank: With front and rear suction devices.

Connection to hydraulic motor: Pump to be connected to the hydraulic motor by a double universal coupling or a thermoid coupling or direct coupled 3:1 gear box. Coupling shall be fitted to provide proper flexibility and reliability due to minor misalignment of hydraulic motor and pump shafts.

To prevent the contamination collected in the discharge strainer from re-entering the pump and tank, the clean-out system shall be filtered or so designed as to prevent this from occurring. Units with filter system shall incorporate a clean-out sump. All vendors must provide adequate plumbing to provide this option to eliminate the potential of abrasive materials being continually passed through the pump.

Recirculating cleanout system: Unit shall be equipped with a recirculating cleanout system, this system shall consist of a separate solvent holding tank mounted on the distributor with necessary valves and piping to circulate solvent through the spray-bar, asphalt pump and piping for cleaning, and then return the solvent to the holding tank. The system is to allow for the use of clean fuel from the diesel burner supply tank as solvent and also allow reusing solvent from the holding tank.

25. PUMP FLUSHING LINE:

A pump flushing line, completed with valve, shall be supplied at a minimum.

26. SUMP (if applicable):

Designed and manufactured to allow all material in tank to flow by gravity into pump or sump.

SPECIFICATIONS
A-48-DB-C-AT

I. GENERAL TRUCK SPECIFICATIONS: (Continued)

E. OIL DISTRIBUTOR: (Continued)

27. TANK INNER SHELL:

The tank capacity shall be approximately 3,000 GAL LPM "MINIMUM" relative to maximum utilization of each GAWR of the truck chassis.

The tank shall be constructed of 0.141 inch (10 gauge) thick steel.

The tank heads shall be a minimum 10 gauge thick, dished and flanged or 8 gauge flat, and shall be fully welded inside and out, continuous electric welding.

The inner tank shall incorporate two (2) "full cross section" material surge baffles 0.141 in (10 gauge) thick. The baffle shall have crawl spaces (staggered) for a man. The baffle shall provide for material drainage and air circulation and shall be welded continually.

Overflow: A minimum of 3 inch diameter, extending a minimum of 6 inch above the tank to prevent loss of material due to material surging while transporting. This overflow pipe shall be located near the tank center. The overflow shall provide proper drainage through the bottom of the tank in a location to clear all truck accessories and equipment.

28. TANK OUTER SHELL:

The tank outer jacket shall be from 0.040-inch thick aluminum of grade 5052-H38, or 0.050 inch thick aluminum of grade 3003-H14.

The outer shell shall be fabricated with sufficient overlap to prevent rain and water entry into the insulation area and constructed in such a manner as to allow for expansion and contraction.

29. WEIGHT DISTRIBUTION, TANK:

The tank body and cabinets shall be designed to provide proper weight distribution for the chassis cab-to-axle dimension proposed. The weight of the tank assembly less chassis weight is required at the pilot model inspection.

30. WIRING AND LIGHTING, TANK:

All lights provided on tank shall meet Pennsylvania Motor Vehicle Code and all wiring shall be Grote Ultra Blue seal throughout. All lights shall be sealed, shock mounted. Wiring shall conform in gauge and color with ATA Standard for asphalt transports. There shall be no connections made outside of a weatherproof box.

31. **OPTIONAL PUMP HEAT CHASE:** If specified, the unit/s shall be equipped with a heat chase from the truck engine cooling system installed. This system consists of two ball valves necessary piping and a jacketed material pump that will allow engine coolant to circulate and heat the material pump.

SPECIFICATIONS
A-48-DB-C-AT

II. DRAWINGS:

EQN-66	dated	Rev.	07-20-09	2 sheets	SPLASH GUARDS-RUBBER
EQN-66A	dated	Rev.	07-20-09	1 sheet	TRIANGLE STORAGE BOX
EQN-78	dated	Rev.	10-27-06	1 sheet	CB RADIO CONNECTIONS
EQN-82D	dated	Rev.	07-22-15	1 sheet	CHOCK AND HOLDER
EQN-94	dated	Rev.	04-18-13	sheet 1 of 2	HOSES AND COUPLERS
EQN-120Q	dated	Rev.	08-06-12	sheet 1	TRUCK LIGHTING UNIVERSAL
EQN-127	dated	Rev.	03-01-07	1 sheet	CONSPICUITY TAPE
EQN-127A	dated	Rev.	01-02-09	1 sheet	REFLECTIVITY ENHANCEMENT
EQN-231	dated	Rev.	06-12-07	1 sheet	TANK CATWALK AND OPERATOR PLATFORM
EQN-351A	dated	Rev.	06-19-13	2 sheets	FAST LUBE OIL CHANGE SYSTEM
EQN-501	dated	Rev.	06-08-09	2 sheets	CENTRALIZED LUBE SYSTEM
EQN-552	dated	Rev.	05-29-13	1 sheet	MAX. TRAVEL HEIGHT
EQN-552-1	dated		03-23-15	1 sheet	THREE POINTS OF CONTACT STICKER

The above referenced drawings shall become part of these specifications.

These drawings reflect the intent of the Department and any discrepancies shall be resolved at the line setting ticket meeting between the vendor and the Equipment Chief, or the pre-production inspection of the truck.

DRAWINGS APPEAR AT THE END OF THE SPECIFICATIONS.

SPECIFICATIONS
A-48-DB-C-AT

III. MANUALS:

The successful vendor shall furnish all applicable manuals per unit:

- 1 Operator's
- 1 Parts
- 1 Service
- 1 Engine
- 1 Transmission (Automatic or Manual)
- 1 Body and Sub-frame (Parts and Service)
- 1 Complete set of manuals for any additional items/equipment added to a piece of equipment.

The manuals listed shall be official O.E.M. publications supplemented with technical manuals for all components as published by sub-vendors/manufacturers.

Parts Manual presented must be a relative to "all" items utilized to build these units, with appropriate part numbers.

Delivery of these manuals shall be completed within a maximum of 90 days after the pilot model is accepted.

Manuals may be supplied on CD Disc in lieu of paper manuals.

SPECIFICATIONS
A-48-DB-C-AT

IV. TRAINING:

Mechanic:

The successful vendor shall provide services of qualified factory trained technicians for not more than 1 training sessions of not more than 7.5 hours at 1 PENNDOT locations to train personnel for in-depth preventive maintenance, overhaul and review of the proper usage of parts and service manuals, as well as component/system adjustments that need to be monitored at specified service intervals.

Operator:

The successful vendor shall provide services of qualified factory trained technicians for not more than 3 training sessions of not more than 22.5 hours at 1 PENNDOT locations to train personnel in the proper operation, safety and servicing of the equipment.

The successful vendor shall submit a training plan to the Fleet Management Division for approval within 45 days after receipt of the Purchase Order. The training plan shall consist of course outline and class schedule.

All training must be completed within 60 days after the dates established in the approved training plan unless an extension is mutually agreed to in writing by the Chief of the Fleet Management Division.

All training shall be coordinated with the District Equipment Managers, with the exception of Asphalt related training, which must be coordinated with the Statewide Training Coordinator (717) 787-4836, Fax (717) 783-4438.

SPECIFICATIONS
A-48-DB-C-AT

V. WARRANTY: Per PCID No. 1075.

ENGINE WARRANTY:

The successful vendor and or supplying OEM shall provide the Department with a 100% parts and labor engine warranty FOR 60 months / 150,000 miles / 5,400 hours minimum. In addition to the engine warranty, the engine block shall be warranted against external perforation from corrosion for 60 months, 100% parts and labor.

NOTE: The oil pan shall be warranted against corrosion, rust, rust thru etc. regardless of atmospheric conditions for 60 months, 100% parts and labor.

EMISSION WARRANTY: The successful vendor and or supplying OEM shall provide the Department with a 100% parts and labor warranty for all emission related components to include the diesel particulate filter (DPF) FOR 60 months / 150,000 miles / 5,400 hours minimum. Shall be warranted against corrosion, rust, rust thru etc. regardless of atmospheric conditions.

RADIATOR WARRANTY:

Manufacturer service and warranty policy for radiator shall be for two (2) years, 100% parts and labor plus an additional three (3) years, 100% parts only.

TRANSMISSION WARRANTY:

Manufacturer service and warranty policy for automatic and manual transmissions shall be 60 months 100% parts and labor.

BODY ELECTRICAL/LIGHTING:

Wiring harness shall be 5 years 100% parts. First year shall include 100% labor.

All LED lights shall be 5 years 100% parts.

NOTE: WARRANTY REPAIRS SHALL BE COMPLETED AT THE MANUFACTURER'S LOCATION OR IN-HOUSE FIELD REPAIR COMPLETED BY PENNDOT. IT SHALL BE THE DEPARTMENTS DISCRETION TO REPAIR INTERNALLY OR TRANSPORT THE UNIT TO THE DEALERSHIP. THE MANUFACTURER SHALL REIMBURSE THE DEPARTMENT AT THE MANUFACTURERS STANDARD PUBLISHED IN-HOUSE LABOR RATE. THE LABOR RATE SHALL BE MUTUALLY AGREED UPON BETWEEN THE DEPARTMENT AND VENDOR/BIDDER. ALL IN-HOUSE WARRANTY DOCUMENTATION SHALL BE DELIVERED WITH THE PILOT MODEL. ALL WARRANTY DOCUMENTATION SHALL BE DELIVERED WITH THE PILOT MODEL.

SPECIFICATIONS

A-48-DH

059600

TRUCK, PAINT, AIRLESS, WATER BORNE, AUTOMATIC

INDEX

I. GENERAL TRUCK SPECIFICATIONS:

- A. Intent Statement
- B. Weight Distribution
- C. Power Train Overview
- D. Vehicle Components
 - 1. Alarm – Backup;
 - 2. Axle Front
 - 3. Axle Rear
 - 4. Brakes
 - 5. Cab
 - 6. Air Conditioning
 - 7. Chassis
 - 8. On Board Grease System
 - 9. Drive Line/Center Bearings
 - 10. Electrical
 - 11. Engine
 - 12. Engine Accessories
 - 13. Exhaust
 - 14. Fast Lube Oil Change System (FLOCS)
 - 15. Frame and Frame Extension
 - 16. Instrumentation
 - 17. Paint
 - 18. Safety
 - 19. Steering
 - 20. Tank - Fuel
 - 21. Transmission
 - 22. Wheels/Tires
 - 23. Collision Avoidance System

SPECIFICATIONS
A-48-DH

I. GENERAL TRUCK SPECIFICATION: (Continued)

E. Paint Machine Overview

1. Paint
2. Platform
3. Bumper
4. Toolbox
5. Rear Shelter and Equipment
6. Intercom System
7. Guidance System
8. Control Center
9. Spray Equipment Control Boxes
10. Electronic Skipline System
11. Spray Equipment
12. Paint Tanks
13. Paint Strainers
14. Paint Fill/Supply Pumps
15. Glass Spray Equipment
16. Glass Supply
17. Spray Gun Carriage Assemblies
18. Heating System - Paint
19. Piping/Valves
20. Air Compressor
21. Cleaner System
22. LED Message Board
23. Lighting/Warning
24. Night Lights
25. Hose Reels
26. Spare Parts
27. Miscellaneous Items
28. Optional Data Logger

II. DRAWINGS:

III. MANUALS:

IV. TRAINING:

V. WARRANTY:

SPECIFICATIONS
A-48-DH

I. GENERAL TRUCK SPECIFICATIONS:

A. INTENT STATEMENT:

NOTE: Pennsylvania Department of General Services PCID No. 1075, "General Requirements for Bidding PennDOT Vehicles/Equipment", most current version effective at the time and date of bid opening is included as a part of this specification. PCID No. 1075 may be reviewed and downloaded from the Department of General Services website, <http://www.dgs.state.pa.us>. Delivery as required per Department of General Service PCID NO. 1075 Section "G". All units must be delivered within **270** days after receipt of the purchase order by the successful bidder.

The maximum height of the paint striper and appurtenances **shall not exceed 11 ft 6 inch** in a working mode.

It is the intent and purpose of this specification to describe a truck-mounted, airless, self-contained striping machine. The machine shall apply reflectorized lines utilizing solvent or water borne traffic paint. The equipment must maintain and be capable of applying the paint and/or marking material at ambient temperatures as low as 50 degrees F, on a clean and dry surface. The machine shall also maintain and be capable of applying conventional or fast-dry traffic paint materials at speeds of up to 20 MPH at a maximum .015 millage/0.381 wet without beads. The intent is to comply with federal safety standards for noise, noise emission generated by the unit (and they shall not exceed federal regulations in the chassis cab, right rear operator's seat, and left rear operator's seat). The machine shall be capable of simultaneously applying three lines in two colors of the marking material in either a solid or skip pattern or combination of these patterns at the operating conditions specified above. All truck parts and materials shall conform to the truck manufacturer's recommendations and the applicable S.A.E., A.W.S. and A.S.M.E. minimum standards.

Department representatives will review the final design of the unit before work begins on the pilot model. The successful low bidder will provide detailed drawings of the various systems; i.e. heating, electrical, hydraulic, etc.

The Department reserves the right to have its representative(s) periodically inspect each unit during assembly at the successful bidder's assembly point.

The vehicle shall have a grade ability of 15% when loaded to maximum G.V.W.R. without exceeding the engine manufacturer's recommended maximum R.P.M., based on maximum net torque. Painting speeds of 5 MPH to 20 MPH must be obtainable without erratic shifting of the automatic transmission. The ratio of the rear axle and transmission shall be geared to maintain a 65 MPH reasonable speed for inter job transporting on expressways without exceeding recommended engine R.P.M. of approximately 2100 to produce the most fuel efficient unit possible without excessive engine R.P.M. and premature wear. I.

SPECIFICATIONS
A-48-DH

GENERAL TRUCK SPECIFICATIONS: (Continued)

A. INTENT STATEMENT: (Continued)

The below-described schedule shall be followed with the successful vendor in the delivery inspection.

After the machine is delivered to the specified location, as shown on the purchase order, the first 10 working days shall be utilized for inspecting the machine to determine whether or not the machine complies with the specifications.

The Department's Traffic Engineering Division personnel and Equipment Division personnel shall make final inspection and acceptance of the machine. Prior to acceptance, the machine shall be successfully operated to the satisfaction of the Traffic Engineering Division personnel, and the Equipment Division personnel with and without assistance from technicians furnished by the vendor.

If the machine meets all the mechanical requirements, electrical/electronic requirements and minimum requirements contained within this specification, then permission will be granted by the Department to the bidder to proceed with fabrication of other machines covered under this contract. If the machine fails to pass the mechanical requirements, electrical/electronic requirements and or the minimum requirements contained within this specification and specified in this contract, the Department reserves the right to reject the machine and any subsequent machines listed on this order.

SPECIFICATIONS
A-48-DH

I. GENERAL TRUCK SPECIFICATIONS: (Continued)

B. WEIGHT DISTRIBUTION:

The complete unit in the full mode shall be weighed to verify that each G.A.W.R. is sufficient relative to the final product presented. The chassis weight and paint body weights shall be furnished separately. The C/G of "both" chassis and paint body shall be provided by means of an engineering drawing(s) at the pre-build meeting.

It is understood that the components specified are minimum and if the truck manufacturer's Engineering Department recommends or deems necessary, due to their particular weight distribution, a larger component or a larger GAWR totally, the burden of responsibility is hereby placed upon the manufacturer's Engineering Department to supply a unit that is totally engineered.

1. Frame
2. Axle
3. Tires
4. Steering unit components
5. Rims
6. Suspension
7. Brakes
8. Any other items as required

The power package required must be compatible with respect to the engine, transmission, axles, hydraulic system, and power steering in order to meet the requirements specified herein.

SPECIFICATIONS
A-48-DH

I. GENERAL TRUCK SPECIFICATIONS: (Continued)

B. WEIGHT DISTRIBUTION: (Continued)

The following information is required:

TRUCK FRONT		TRUCK REAR	TOTAL
	Chassis Weight		
	Diesel Fuel Gal. @ 7 LB per Gallon		
325	Truck Driver & Misc. Weight		
	Body & Related Platform Components		
	Paint Payload @ 13.0 LB per Gallon		
	Beads Payload @ 7000 LB		
	Paint operators 2 @ 250 LB Each		
	TOTAL WEIGHT		

When fully laden with fuel, striping material and operators, the chassis manufacturer's axle and total GVWR ratings shall not be exceeded or the unit may be rejected. The unit shall meet all current OSHA standards for noise levels at platform level and the operator locations.

Vendor shall submit this information and each unit shall be weighed by a certified weigh master and signed.

Chassis _____ Front Axle
 Without Paint _____ Rear Axle
 _____ Total

Truck GAWR's as Built

<u>Front GAWR:</u>	<u>Rear GAWR:</u>
Axle _____	_____
Tires _____	_____
Springs _____	_____
Rims _____	_____
Brakes _____	_____

SPECIFICATIONS
A-48-DH

I. GENERAL TRUCK SPECIFICATIONS: (Continued)

B. WEIGHT DISTRIBUTION: (Continued)

The successful vendor shall provide two (2) decals with the above information inside the truck operator door and the height information on Page 10. A copy of the decals shall be provided with each unit.

Engineering Concurrence:

This specification and all specified components must be reviewed and approved by the successful Original Equipment Manufacturer (OEM). The installation of the specified components must be approved by the successful manufacturer's Engineering Department.

CHASSIS SECTION: SUGGESTED CHASSIS ARE THE AUTOCAR ACX, MACK MRU OR PETERBILT 320.

C. POWER TRAIN OVERVIEW:

NOTE: LUBRICANTS FOR FRONT AXLE HUBS, DIFFERENTIALS, AUTOMATIC TRANSMISSIONS, TRANSFER CASES AND ALL REAR DIFFERENTIALS SHALL MEET OR EXCEED ALL APPROPRIATE MIL AND SAE SPECIFICATIONS FOR SYNTHETIC LUBRICANTS AND SHALL HAVE ALL PLUGS IDENTIFIED AS SYNTHETIC OR PAINTED RED.
(The OEM shall provide written exemption if synthetic oil is not installed).

ENGINE

Minimum 365 hp 1340 torque.

NOTE: If additional HP is available, it may be included in an effort to give the Department the maximum available.

TRANSMISSION AUTOMATIC

ALLISON RDS 4500 6 SPEED

Automatic transmission cooler lines shall be stainless steel or a **preapproved** no-rusting material.

REAR AXLE

46,000 LB axle/s-total.

Rear axle ratio shall be selected at prebuild using operation requirements defined in the intent statement.

SPECIFICATIONS
A-48-DH

I. GENERAL TRUCK SPECIFICATIONS: (Continued)

D. VEHICLE COMPONENTS:

1. ALARM - BACKUP:

ECCO 450 shock mounted.

2. AXLE FRONT:

20,000 LB capacity "I" beam type, minimum, relative to weight distribution.

The front axle grease fitting locations must be provided with zerks.

Stemco, oil seal assembly or equal.

RE: Above GAWR minimum relative to Engineering Department weight distribution chart.

3. AXLE REAR:

46,000-lb capacity, air ride suspension.

Suspension shall be tailored to axle loads and shall be adequate to sustain maximum GVW without overload or permanent set.

Stemco rear wheel seals, or equal.

All rear axle hardware shall be grade 8, with self-locking nuts.

The rear axle housings shall not be aluminum or lightweight component type.

NOTE: Twin screw rear. Power in both rear axles with driver controlled diff lock.

4. BRAKES:

Full air antilock in compliance with the most current FMVSS requirements.

Air compressor with dash-mounted gauge(s).

The air tank or tanks shall be mounted as required by the paint machine manufacturer (inside frame).

Buzzer-type, low air pressure with light as indicator.

Parking brake warning light.

Spring-type, rear wheel-parking brake, size 30/30 chambers with proper brackets to obtain the following.

SPECIAL NOTE: Rear brake chambers mounted forward or above axle to provide adequate road clearance and for paint gun carriage clearance REF: MGM

Automatic air tank drain valve with heater on the (first) tank. (Ref: Bendix). DV-2 drain valves with heater.

Each of the remaining air tanks shall have a manual drain valve.

Air dryer installed with heater outside frame rail unobstructed. Meritor, Wabco or equal.

Dryer installation shall be in concurrence with the air compressor manufacturer's recommendations.

16.50 inch x 7 inch or 18 inch x 7 inch rear brakes.

"S" cam single anchor pin or quick-change type, double-anchor pin.

SPECIFICATIONS
A-48-DH

I. GENERAL TRUCK SPECIFICATIONS: (Continued)

D. VEHICLE COMPONENTS: (Continued)

4. BRAKES: (Continued)

16.50 inch x 6 inch "S" cam steer axle brake (no substitute, standardization).

16.50 inch x 7 inch or 18 inch x 7 inch rear brakes.

"S" cam single anchor pin or quick-change type, double-anchor pin.

16.50 inch x 6 inch "S" cam steer axle brake (no substitute, standardization).

Quick change type single or double anchor pin if drum-type brakes are furnished.

Drum brakes shall have automatic slack adjusters and they shall be clearance-sensing type only with adjustment on application of the brake.

5. CAB:

Aluminum or steel cab (low tilting type).

One or two-piece windshield. The windshield shall provide optimum square footage of glass to ensure operator visibility.

Drivers and passenger windows shall be manual.

Seats: Driver's seat and passenger seat shall be mid-back adjustable BOSTROM Air 905 Series with lumbar support with lumbar support with body cloth insert and three-point retractable seat belt **(Seatbelts shall be High Visibility Orange)**.

Driver seat shall have a left side arm rest.

Deluxe fresh air hot water heater, manufacturers highest output.

Cab lights, Shall be LED.

Dual windshield defrosters.

Dual windshield wipers: Heaviest arms, motor and linkages available, maximum length.

Washer tank: Shall be filled with an anti-freeze type solvent.

Inside dome light(s)

Top of the first step shall be at a maximum of 22 inch above the ground.

Grab handles shall be supplied on all cab entry locations. Three points of contact shall be achievable at all cab entry locations. Handrails shall be coated with non-skid paint (non-skid tape is unacceptable) or have OEM anti-slip rubber inserts, both non-skid paint or rubber inserts must extend the full length of the grab handle.

Exterior grab handles shall be supplied if available from OEM.

Dual inside sun visor.

Mirror(s): Electrically adjustable (powered) on both sides. 6 inch x 16 inch minimum west coast type and with heated round convex mirrors. The wires shall be fitted in such a way that the mirror glass/element can be changed by unplugging the two-wire lead. Mirrors and arms shall be stainless steel, aluminum or chrome.

Dual electric horns and air horn.

Tinted safety glass throughout AST-I.

All controls and knobs shall be properly identified.

Areas likely to be walked or stepped on shall be serrated. The size and strength shall be in accordance with the truck manufacturer's step design but the material shall be as noted above. Step design and material shall be the same design and material on the left and right side.

The cab floor covering shall be heavy-duty rubber with closed cell rubber or heavy felt backing.

CB power connectors, one (1) pair, dash mounted. Both male/female ends shall be supplied per EQN -78.

Emergency triangle warning kit, with hold down, (fastened) in the cab.

If air ride cab suspension is available, it shall be included.

SPECIFICATIONS
A-48-DH

I. GENERAL TRUCK SPECIFICATIONS: (Continued)

D. VEHICLE COMPONENTS: (Continued)

5. CAB: (Continued)

Steering wheel diameter shall be 18 inch (approx.) manufacture's standard.

AM/FM radio with CD.

There shall be a permanent decal, 2 inch high red letters on white back ground affixed by the driver side door handle stating the overall maximum travel height of the completed and unloaded unit.

(Example) HT-__' __" Ref. EQN-552

There shall be a permanent decal, "Three Point Contact" located at each entry point of the truck cab and at the bed ladder area per EQN – 552-1. Exact location to be determined at pre build meeting.

6. AIR CONDITIONING:

Integral air conditioner with heater. Manufacturer's highest output available.

Cab and rear shelter shall be separate systems.

7. CHASSIS:

C.A. dimension and wheelbase shall be determined by the manufacturer to provide optimum weight distribution.

The main frame shall be full length, including the required AF for paint gun carriage.

License plate bracket rear.

Splash guards per EQN-66

8. ON BOARD GREASER SYSTEM

There shall be a centralized on board chassis lubrication system installed. Ref: EQN-501.

9. DRIVE LINE/CENTER BEARINGS:

Main driveline: Spicer Life XL or Meritor MXL Series. "**Factory balanced**" greasable, (one zerk minimum).

Heavy-duty driveline shall be engineered and be compatible to engine, drive train and transmission torque. Heavy-duty center bearing, if required, with due consideration to drive shaft angles, length, location, proper bolting based upon engine and transmission selection. Inter-axle driveline: Spicer Life XL or Meritor MXL Series.

10. ELECTRICAL:

Primary wire and battery cables shall be copper, negative ground.

Batteries: Three (3), heavy-duty, 12-volt, maintenance-free, BCI Group Size 31, with stud-type posts and anti-corrosion treatment on each terminal. 2500 total cold cranking amperes (CCA) at 0 degrees F.

Battery Mounting: It shall include the following:

- a) 0.25 inch thick rubber shock pad under the battery(s).
- b) Box with cover. Cover shall be constructed of fiberglass, poly or aluminum. If aluminum is used, there shall be an insulating liner.
- c) Mounting bolts shall be grade-8 with self-locking nuts.
- d) Kalas terminals shall be located on battery box for remote access.

Mounting of accessories within the battery box is prohibited.

SPECIFICATIONS
A-48-DH

I. GENERAL TRUCK SPECIFICATIONS: (Continued)

D. VEHICLE COMPONENTS: (Continued)

10. ELECTRICAL: (Continued)

All chassis lighting shall be L.E.D.

Electrical system: Circuit-breaker-equipped, in easily accessible location, weatherproof.

Fuses and circuit breakers shall be labeled within the battery box.

Fuses acceptable in circuit so identified by manufacturer as safety factor. Any fuse or circuit breaker liable to be damaged during truck operation shall have an easily removable protective cover.

Alternator: Shall be a Delco (No substitute, standardization) 200-amp minimum, high performance, solid state.

Starter motor: Delco 39 MT (No Substitute, Standardization) with thermal over-crank protection and high torque capacity. Suitable for the diesel engines offered as per starter manufacturer's recommendation.

Alternator and starter mounting bolts shall be Grade 8.

Flasher: (All) heavy-duty electrical, Ref: Tridon Model EL 12 or equal.

Note: If an audible alarm is supplied for 4 ways and turn signals, it shall have an on/off capability.

GPS Combo Radio Antenna: There shall be a pedestal mount base with built-in GPS, PCTEL model GPPB-204-54-12-S1-M1 and a low profile black antenna, PCTEL model BMLPU700. Assembly shall be mounted on pedestal with mini light bar, with the antenna cable routed to the front dash area between the seats towards windshield. There shall be a minimum of 1 feet of antenna cable coiled at the base of the dash to allow for connection to department radio. Antenna shall be prewired with a MINI - UHF MALE connection. (No substitute, standardization). No mounting in roof. REF. EQN-120Q

Power Distribution Center: There shall be a 4-way power/ground distribution center located on the underside of the dash for connection of department state radio. The lugs shall be configured in the following manner: (1) lug shall be a 30 ampere constant hot circuit, (1) lug shall be a 10 ampere ignition controlled circuit. (2) lugs shall be chassis ground. All connections shall be enclosed in a weatherproof enclosure.

Electrical wiring: Chassis and body wiring harness shall be protected at areas prone to cause chafing by installing convoluted plastic conduit and clamped using steel band clamps with rubber inserts.

All exposed junctions: Waterproof and sealed against salt.

11. ENGINE:

See POWER TRAIN OVERVIEW for acceptable engines.

Replaceable heavy-duty, full-flow type filter(s) and oil filter(s) as recommended by the engine manufacturer, bearing a legible OEM part number.

Cooling system: The system shall be the largest factory engine cooling capacity, compatible with engine and transmission referenced for continuous high engine output under extreme temperatures and/or operating conditions due to prolonged operations in low gears. The water pump shall be adequately sized to provide proper cooling and be of sufficient size, to adequately handle the specified options. Shall be fitted with provisions for visually monitoring coolant without necessitating removal of the cap from the radiator or expansion tank (e.g. sight glass, transparent expansion tank). The antifreeze solution shall meet all applicable EPA requirements.

Radiator core and shell: Shall be manufacturer's heaviest construction grade radiator available.

SPECIFICATIONS
A-48-DH

I. GENERAL TRUCK SPECIFICATIONS: (Continued)

D. VEHICLE COMPONENTS: (Continued)

12. ENGINE ACCESSORIES:

The oil dipstick must have tubing and dipstick of sufficient length to provide reasonable access.

Coolant filter: Sized for and compatible with the cooling system and non-charged.

Air Cleaner: Air filter shall be manufacturer's heaviest duty air cleaner that meets all the requirements of the extended engine warranty.

Fan: Auto/manual controlled fan as per manufacturer's recommendations.

Screening system: Mounted in front of radiator grille that protects entire radiator from stones and bugs.

Air restriction gauge: Flush, dash-mounted with indicator slide for engine air cleaner, RE: FILTER MINDER, manufactured by Engineered Products Company. If the vehicle is OEM equipped with an electronic dash that incorporates an air restriction gauge or indicator light, it shall be acceptable.

Cruise control: Factory and capable of being set to low speeds of 5-20 MPH.

Governor: Set at manufacturer's recommended maximum engine speed (rpm).

ECM shall be set to a maximum of sixty five (65) miles per hour.

Automatic idle shutdown shall be set to five (5) minutes. An audible warning alarm shall be provided to alert operator prior to engine shutting down.

Hoses: Cooling system hoses under 1 inch OD may use factory-standard hose clamps as a minimum acceptable standard. Air intake hoses shall be 0.25 inch minimum thickness, molded hoses. Ref: GATES, GOODYEAR or equal. Silicone radiator and heater hoses.

Drive belts: Cog belts, or serpentine.

SAE #1 engine bolt circle to accommodate transmission specified.

Engine Alarm System: High temperature, low oil, and low water level shall incorporate a bell and light system.

Engine shall be equipped with a minimum 3 stage, full engine compression brake, Brake lights shall activate when engine brake is activated Ref: Jacobs.

13. EXHAUST:

Vertical tailpipe with elbow and muffler system or approved horizontal muffler and vertical tail pipe with elbow. System shall be directed straight up to offer maximum platform availability.

The muffler/DPF and tail pipe shall be shielded or insulated to protect personnel from burns when entering or exiting the cab and platform area. The shield shall be 180 degrees to 360 degrees and shall be of non-rustable material such as stainless steel or aluminum. Rinker or equivalent.

14. FAST LUBE OIL CHANGE SYSTEM (FLOCS):

This FLOCS system shall be installed with all fittings, brackets, clamps and hoses. Hose from oil pan to FLOCS fitting shall be hydraulic hose with a 100R2 rating and properly secured. The system shall be compatible with all fittings presently used by the Department. The final placement of the male half of the snap coupler, on the equipment, shall be determined at the pre-build meeting. Ref: EQN-351A.

There shall be a "FLOCS connections" decal to direct the operator.

SPECIFICATIONS
A-48-DH

I. GENERAL TRUCK SPECIFICATIONS: (Continued)

D. VEHICLE COMPONENTS: (Continued)

15. FRAME AND FRAME EXTENSION:

The Resisting Bending Moment (RBM) shall be a minimum of 1,000,000 inch LB per rail, for the entire length of the frame including any frame liners, except where engine and radiator adjustments are required. Frame material shall be of at least 110,000 PSI yield strength. (Drop frames are not acceptable).

Minimum frame RBM shall be approved by manufacturer's Engineering Department.

Main frame and any required liners shall be either straight channel or offset channel, full length. No welding shall be done and no holes drilled on the main frame rails without approval of the frame manufacturer.

There shall be no front or rear frame extension. Bolt-on or welded extension will not be accepted. The vendor shall select main frame rails of adequate length to suit the body/platform.

Front bumper shall be steel. Bumper shall be directly mounted to the frame.

16. INSTRUMENTATION:

All instruments illuminated and dash-mounted except where specified otherwise.

All standard instruments shall be supplied, including but not limited to the following:

Gauges: Oil pressure gauge with warning light or audible alarm.

Air pressure: gauge(s) for dual circuit, dual indicator with low-pressure audible alarm.

Coolant temperature: with warning light or audible alarm.

Transmission oil temperature: for automatic transmission only, with warning light or audible alarm.

Hour meter that records only when the engine is running, Ref: DATCON or equal shall be readable from the driver's seat.

Speedometer with odometer.

Digital speedometer shall be mounted on driver's left side corner cab post.

Tachometer

Voltmeter

Parking brake indicator light.

17. PAINT:

Cab, shelter, deck and all above deck items shall be painted PennDOT yellow, Ref: DuPont F9885, PPG 85246 Sherwin Williams 73266, Sikkens 4017 and NAPA 73266 for shade only.

Frame, Front bumper and all underside components shall be primed and painted black (with hardener) low VOC. All bare metal surfaces (except aluminum and stainless steel) shall be coated using etching primer prior to paint. All surfaces shall be properly cleaned and prepared prior to paint, with all weld splatter and debris removed.

18. SAFETY:

Grab handles shall be supplied on all cab entry locations. Three points of contact shall be achievable at all cab entry locations. Handrails shall be coated with non-skid paint (non-skid tape is unacceptable) or have OEM anti-slip rubber inserts, both non-skid paint or rubber inserts must extend the full length of the grab handle.

Exterior grab handles shall be supplied if available from OEM.

SPECIFICATIONS
A-48-DH

I. GENERAL TRUCK SPECIFICATIONS: (Continued)

D. VEHICLE COMPONENTS: (Continued)

18. SAFETY: (Continued)

All steps shall be serrated. The size and strength shall be in accordance with the truck manufacturer's step design. The outer step edge must be serrated in lieu of plain, smooth metal edge.

Top of the first Step shall be approximately 21 inches above the ground.

There shall be one (1) warning light mounted on a pedestal just aft and above cab. Light shall be visible for on-coming traffic. Mini light bar to be wired in conjunction with front (grill), side (middle of deck) and rear (Shelter) warning lights. The lights shall be per EQN-120Q (with hole in bracket for mounting of Department State Radio).

Triangles, storage box and bracket shall be included Ref. EQN-66A.

Conspicuity requirements per EQN-127A.

Wheel chocks shall be provided and mounted within easy reach. Per ENQ-82

Fire extinguisher: Rechargeable with vehicle mount and shall be mounted in the cab or externally in close proximity to the chassis cab (if external, it shall have a red weatherproof cover) for easy and quick access. Ref: 3A:40B:C.

Fire Suppression System: There shall be a fire suppression system installed for the truck engine compartment and for the air compressor compartment. A unit shall be mounted in such a manner to allow for maximum coverage of affected area. The unit shall be an automatic system, while retaining the ability to be a manually activated from the cab. There shall be an audible and visual alarm in clear sight for the vehicle operator. Ref. System-Jomarr model Vt-6 fire suppression system (717) 346-5330.

19. STEERING:

Power steering: Dual integral or single integral types hydraulic with right wheel power assist cylinder. With stops to prevent damage to system.

GLIDECOAT steering shaft or equal.

Steering system (e.g. flow, pressure, relief valve etc.) shall be selected considering the full front axle loading. Ref: ROSS, SHEPPARD or TRW gear assembly.

Hydraulic supply pump: Vane type or roller type, with sufficient oil flow to permit one (1) steering wheel revolution per second, in a "park" condition.

Power Steering Reservoir: "Remote-mounted", and factory-mounted, minimum two- (2) quart capacity, incorporating a filter, which is easy to remove and replace.

20. TANK - FUEL:

Safety - type fuel tank(s) as per the requirements of FMVSS.

100 gallon minimum total usable capacity, single, mounted tank Cylindrical shaped with formed sump. Aluminum or stainless steel unpainted.

Tank mounting hardware and brackets shall be stainless or aluminum heavy duty brackets with rubber gaskets.

Dual tanks are unacceptable.

SPECIFICATIONS
A-48-DH

I. GENERAL TRUCK SPECIFICATIONS: (Continued)

D. VEHICLE COMPONENTS: (Continued)

21. TRANSMISSION: See POWER TRAIN OVERVIEW for acceptable transmission.

The transmission must be capable of maintaining a constant speed of 5 to 20 MPH without up shifting or downshifting. Equipped with a single or three gear charging pump.

Console control shall incorporate all hold identifications.

Oil cooler for transmission as required due to prolonged transmission converter operation in second gear, maximum cooler size must be provided to keep oil at acceptable operating temperature. (Water to oil type cooler).

Automatic transmission cooler lines shall be stainless steel or a **preapproved** no-rusting material.

The transmission and rear axle shall be geared to provide a road speed of up to 65 MPH.

The truck transmission and rear axle shall be geared for efficient operational speeds of between 5 and 20 MPH at a maximum grade of 15%. The transmission hold system shall be furnished to provide these operational speeds without the transmission over shifting and seeking a new gear as these needs vary regardless of highway gradient.

22. WHEELS/TIRES:

GENERAL:

The truck/s shall be equipped with Accuride 10-hole hub piloted steel disc wheels for radial tubeless tires front and rear.

The wheel end shall be equipped with outboard cast brake drums.

All tires will be radials (straight Tread, Steering type) no substitute.

The front tires shall be 425/65R22.5 (Load Range L) while satisfying all OEM requirements.

The rear tires shall be 12R22.5 (Load Range H) while satisfying all OEM requirements.

Truck and Body Company shall ensure proper sized tires and wheels for GVWR provided.

Wheels shall be painted grey, white or argent in color.

Wheel-Guard Separators:

The wheel ends shall be equipped with the Accuride part number 5903 Wheel Guard Separator as follows:

Front axle - between the wheel and the brake drum.

Rear axle - between the inner dual and the brake drum and between the inner and outer duals.

23. COLLISION AVOIDANCE SYSTEM:

There shall be a CAS installed. Monitor 7 inch LCD color monitor min. shall be cab mounted.

Camera shall be mounted on the rear of the truck.

CAS shall be weatherproof.

Ref: Wintron Technologies 1-800-865-5351

Preco Safety Products 1-800-453-1141

SPECIFICATIONS
A-48-DH

I. GENERAL TRUCK SPECIFICATIONS: (Continued)

E. PAIN T MACHINE OVERVIEW:

1. PAINT:

The complete machine and all components, including tanks, compressor, etc. above the platform, shall be properly prepared and painted PennDOT yellow. Ref: DuPont F9885, PPG 85256, Sherwin Williams 73266 and NAPA 73266 for shade only. All components below the platform shall be painted gloss black.

2. PLATFORM:

The vendor shall supply and install on the chassis a steel platform of adequate size to accommodate all relevant equipment. The platform framing shall be constructed of a minimum 4 inch steel structural channel so as to support all required equipment mounted on it, spaced on approximately 16 inch centers. The spacing of these cross members shall not exceed 17 inch.

The platform shall be supported by two (2) structural steel "C" channel. "U" bolts or grade 8 bolts with self-locking nuts and two (2) shear plates shall be utilized to secure the platform to the truck chassis frame. Mounting practices in accordance with N.T.E.A. standards.

The platform shall be fabricated to provide adequate spacing for servicing and maintenance of the paint supply lines, fittings, and valves. Spacers utilized between the truck frame and body longitudinal shall be manufactured to support a fully loaded platform without flexing or twisting.

The platform ladders and handrails shall be steel. The platform shall be a minimum 8 GA non-skid steel safety tread surface. All handrails shall be covered with anti-skid paint. A minimum of four (2 per side, 1 front side and 1 rear side) ladders shall be furnished to provide easy access to the platform. Ladders shall be steel. The outer step edge must be serrated in lieu of plain smooth metal edge. Ladder/s safety chain shall be no more than 72 inches from ground level. (Ladder location to be determined at pre-build meeting).

There shall be a permanent decal, "Three Point Contact" located at each entry point of the truck cab and at the bed ladder area per EQN – 552-1. Exact location to be determined at pre build meeting.

Rear wheel fenders, aluminum, for protection of the rear axle tires, shall be affixed below the platform. Fenders shall be constructed in accordance with the Commonwealth's vehicle inspection requirements.

A 1-1/4 inch minimum steel square railing shall be installed around the platform where necessary and bolted in place. The height of the railing shall be a minimum of 42 inch. Railing shall be properly supported (e.g. plates and/or gussets) at its base to eliminate flexing of the deck.

3. BUMPER - REAR:

The rear bumper shall be a minimum of sixteen (16) inches wide and extend across the rear of the truck platform. It shall be a minimum 18 inch (bottom edge) above the road surface and have a steel open grip strut surface. Shall be a maximum of 24 inch to top of step. The bumper support shall be at least 4 inch x .1875 inch-channel steel on both sides and the bumper should be of (minimum).250 inch thick steel channel with welded end section forming a strong box section. Piping shall not extend below rear bumper.

SPECIFICATIONS
A-48-DH

I. GENERAL TRUCK SPECIFICATIONS: (Continued)

E. PAIN T MACHINE OVERVIEW: (Continued)

4. TOOL BOX:

Three aluminum weatherproof, lockable tool boxes, 16 inch x 19 inch x 18 inch (approximately) shall be supplied. The boxes shall have a drop door with a safety latch. A fourth box 21 inches deep x23 ¼ wide x 7 ¾ high shall be located under the rear shelter step, with a drop door and a sliding tray. Any special tools needed for adjustments or disassembly of the various machine components shall be furnished in these boxes. Final locations of these toolboxes shall be decided at the pre-build meeting.

5. REAR SHELTER AND EQUIPMENT:

Ref. **EQN-370-60”**.

The entire shelter shall be structurally self-sufficient and rubber mounted to the cross channels.

The cab shall be constructed of formed aluminum, modular construction.

Inside bulkheads and roof shall be insulated. (Ref. D B Engineering “tan” cab insulation, Tel:(214) 484-8890, or equal. All edges shall be sealed with a silicone sealer.

Vinyl-clad foam insulation shall be installed on the interior of the cab for both insulation and sound deadening properties. In addition, the floor of the cab shall be clad with a thick rubber mat for sound suppression. Front and rear access doors must be waterproofed and lined with bulbous weather stripping.

Tinted safety glass throughout AST-I or metal panels in the bottom of the shelter to be determined at the pre-build meeting.

All windows shall be tinted safety glass with rounded corners for strength and safety. All windows shall display proper identification marks. Square corners will be unacceptable for this application.

The rear windows behind the operators shall be double track slide opening for ventilation.

Side bubble window shall be installed at each operator position in the rear shelter.

There shall be a sliding front access door.

The steps entering the rear shelter shall be approximately 7 inches deep.

There shall be a permanent decal, “Three Point Contact” located at each entry point of the truck cab and at the bed ladder area per EQN – 552-1. Exact location to be determined at pre build meeting.

Grab handles shall be supplied on all cab entry locations. Three points of contact shall be achievable at all cab entry locations. Handrails shall be coated with non-skid paint (non-skid tape is unacceptable) or have OEM anti-slip rubber inserts, both non-skid paint or rubber inserts must extend the full length of the grab handle.

Exterior grab handles shall be supplied if available from OEM.

The cab shall be cooled by a wall mount air conditioning unit powered by the diesel auxiliary engine or the chassis engine. The air conditioner shall have a minimum rating of 25,000 BTU with R134 refrigerant and heated with a minimum 40,000 BTU heater with duct work to both operators.

Heater with fan shall be provided with controls in the paint operator area. A summer by-pass valve shall be provided to eliminate heat in cab in summer months. Hoses shall be protected against burst, hoses shall be covered with hose sleeving (full length of hose) to protect operators against burns from hose rupture. Silicone heater hoses shall be utilized and previously specified clamps in the truck specifications. Heater shall have sufficient BTU output to keep this area comfortable and shall be a copper cored unit.

SPECIFICATIONS

A-48-DH

I. GENERAL TRUCK SPECIFICATIONS: (Continued)

E. PAIN T MACHINE OVERVIEW: (Continued)

5. REAR SHELTER AND EQUIPMENT: (Continued)

Switch controlled dome lights shall be installed over each operator's station. Night lighting shall be provided in the cab. The control center shall be lit in addition to an overhead dome light.

There shall be an AM/ FM weather band radio with CD player and audio jack and two speakers in the shelter.

Seats: Two (2) shall be high back adjustable with lumbar support with body cloth insert and two-point retractable seat belt (**Seatbelts shall be High Visibility Orange**). A bellow-type protective skirt shall cover the seat air suspension mechanism. There shall be one armrest for left/right side, mounted to the inside shelter wall at each window. The seats shall be able to swivel so the operator can turn to the left or right, and lock at ¼ inch intervals. REF. National Captain 2000 Series or BOSTROM equal.

C.B. power connectors: (2 pair) in rear operator's cab per EQN-78.

Both male/female ends shall be supplied.

CB shall not be supplied.

There shall be a shelter operated emergency paint shut-off for the paint supply.

Rear panel of shelter and rear bumper shall have Chevron decal added Ref. EQN-122

FIRE EXTINGUISHER SYSTEM:

There shall be four (4) strategically placed rechargeable dry-chemical 10 ABC-rated fire extinguishers (1 per I.D.17 and in or within close proximity to the rear shelter) with charge condition indicator gauge.

Extinguishers shall be in compliance with NEPA #385 and federal motor carrier safety regulation.

If mounted on the exterior they must be protected with removable red waterproof covers for easy and quick access.

Fire Suppression System: There shall be a fire suppression system installed for the truck engine compartment and for the air compressor compartment. A unit shall be mounted in such a manner to allow for maximum coverage of affected area. The unit shall be an automatic system, while retaining the ability to be a manually activated from the cab. There shall be an audible and visual alarm in clear sight for the vehicle operator. Ref. System-Jomarr model Vt-6 fire suppression system (717) 346-5330.

6. INTERCOM SYSTEM:

DAVID CLARK MODEL #9900 INTERCOM SYSTEM (No substitute).

A David Clark Model 9900 intercom system shall be provided in apparatus, it shall be the sole responsibility of the successful vendor to ensure compatibility with the Department's Radio system, the system shall be interfaced and include all cables and hardware needed to be completely operational with the Departments two-way radio system before delivery. (Note: an authorized two-way radio installer shall be responsible for interfacing the intercom system with the two-way). For information on the department's radio system contact the Fleet Management Division at (717)783-2889.

SPECIFICATIONS
A-48-DH

- I. GENERAL TRUCK SPECIFICATIONS: (Continued)
- E. PAINT MACHINE OVERVIEW: (Continued)
- 6. INTERCOM SYSTEM: (Continued)

HEADSETS & Belt Stations FOR DAVID CLARK SYSTEM

The intercom system shall include:

Four (4) model H9940 under-helmet radio transmit headsets shall be furnished for the system seating locations in the cab. The headsets shall have M87-type noise-canceling microphone, immersion-proof, all hardware marine-grade stainless steel, and Dynamic earphones with stainless steel retainers, adjustable head strap, and a hybrid-style boom which rotates for left or right placement. The intercom headsets shall have adjustable volume controls in both ears. The sets shall also have comfortable gel ear seals. All users shall have a U9910-BSW, VOX Intercom belt station, with radio PTT function, and easily accessible battery compartment with removable Li-Polymer battery. One (1) model H3492 single-ear headset shall be supplied, to be used by the driver.

System Wireless Gateway

The system shall have a U9922-G38 wireless gateway capable of hands-free, full-duplex intercom. The gateway shall provide a range of up to 300 feet (line-of-sight) to all linked Belt Stations. The gateway shall be capable of radio interface, provides radio monitor and transmit capability for all wireless users. Shall have (2) SMA Antenna connectors for whip antenna, or remote antenna connection.

Wired Station / Radio Interface:

The U3800 **wired** Master Station accommodates up to (2) wired headsets that communicate with the wireless headsets via the U9922 Gateway to be installed in the cab of the truck. The U3800 Master Station is to include one U3815 radio interface module to allow two-way radio interface, one C3821 Radio interface harness, and one C3820 power harness. (Note: an authorized two-way radio installer shall be responsible for interfacing the intercom system with the two-way).

Battery Charging System

A 12V DC charging unit, 4-bay, shall be provided capable of accommodating up to 4 each 3.7V Li-Polymer batteries, used in Series 9900 Belt Stations. The charging system will provide constant thermal monitoring of battery thermistors, and LED indicators for individual visual charge status. There shall be four (4) additional batteries supplied as backups while one set is being charged. Charger shall be mounted in rear shelter.

SPECIFICATIONS

A-48-DH

I. GENERAL TRUCK SPECIFICATIONS: (Continued)

E. PAINT MACHINE OVERVIEW: (Continued)

7. GUIDANCE SYSTEMS:

An optical sight shall be mounted inside of the chassis cab. The sight shall include the necessary light source, lens system and mirrors to project a virtual image of a luminous sighting pattern onto a distant target. A housing, mounting and adjustment linkage shall be provided for positioning and clamping the optical sight in the best location for the vehicle operation. Two (2) pair Glasses to improve/enhance visibility.

LASER DOT GL-3000-P on cab roof. There shall be supplied a GL-3000-P Laser System using an ultra-high visibility green laser to establish visual line control for the paint striping machine. The operator adjusts the laser spot to the desired reference point on the road via a remote control panel located in the cab of the truck.

The laser, all optics, mechanical mechanisms, and electronics shall be located in a rugged, weatherproof housing that is typically mounted to the roof of the truck. This permanent installation shall eliminate the need to remove the laser at the end of the day. Two cables shall run from the laser housing, one for 12V DC power, the other for system control in the cab.

8. CONTROL CENTER:

Aluminum or steel control center shall be provided. The control center shall be mounted inside the rear shelter in a manner to allow ample access for servicing and repair.

Control panel shall be mounted in an inclined position, so that it can be observed from either operator's position.

Each gauge and valve on the control panel will be identified with a photosensitive label, metallic type and/or engraved laminated plastic.

A removable plate shall allow access to the interior for service; it shall tilt outward via a piano hinge.

A 125 PSI safety valve shall be located on the rear of the panel air manifold.

9. SPRAY EQUIPMENT CONTROL BOXES:

The spray equipment shall be electrically controlled by means of solenoid valves and individual toggle switches.

The switches shall be mounted in a portable control box at each operator's position.

The holder shall be made of material to withstand heavy use.

The entire switch assembly shall be removable from the control box holder for servicing and is attached by a pin connector type harness (phone jack type plug) to an electrical junction box.

Control box bracket and track shall be made to withstand heavy use.

Bracket shall be easily adjustable for height and lock in place.

Track shall be mounted to the side of the rear shelter at each operator position to allow the controls to be moved front to back, to accommodate the operator sitting in the seat.

Each striping machine supplied shall be provided with one additional control box for use as a spare.

A plug, coiled cord and thumb-button control for manual restriping shall be provided at each location.

Wiring harness shall be connected to control boxes by means of a male, female type connector (phone jack type plug) for quick replacement of control boxes.

All line pattern combinations, skip line mechanism actuation, and skip line combinations can be obtained by activating only one switch that also simultaneously activates or resets the skip line mechanism.

SPECIFICATIONS
A-48-DH

I. GENERAL TRUCK SPECIFICATIONS: (Continued)

E. PAINT MACHINE OVERVIEW: (Continued)

9. SPRAY EQUIPMENT CONTROL BOXES: (Continued)

The remaining toggle shall be an off switch (master), connected in such a way that when activated, it will turn off and cancel any of the above selected patterns, as well as automatically reset the skip line mechanism to a ready position. Provision shall be made so that sphere gun(s) may be controlled by activating a switch on the portable control box for independent and/or simultaneous binder and glass sphere operation.

There shall be a pin connector type harness (phone jack type plug) on the right side to connect the control box from the left side for the capability to operate the left side carriage patterns from the right side operator seat.

There shall be a bracket on the right side to mount the left side control box above the right control box for operation when there is only one operator in the rear shelter.

10. ELECTRONIC SKIP LINE SYSTEM:

The electronic skip line system shall be Skip Line Inc. SC-12.

Two skip line systems shall be included in the striping unit that will allow remote application of various pre-selected line patterns on the fly.

NOTE: SKIPLINE SHORT & LONG FOR BOTH SIDES SHALL WORK INDEPENDENT OF EACH OTHER.

Digital speed meter system: A digital speed meter shall be included on the striping unit that will allow the truck operator to read his speed in three (3) digits to aid him in maintaining a desired speed.

The signal source shall be a logic level pulsing unit driven by a pulse generator mounted off the driveline.

The 12-volt DC power for the system shall be provided by the truck alternator and be separately fused.

It is the stated intent of this specification to describe a highly reliable, easy to use, simple to install, compact skip-setting mechanism that requires little or no maintenance and no clutches, cams, gears, bearings or devices that must be adjusted while at rest.

The skip timer control boxes shall use mid-sized IP67 rated toggle switches and shall use sealed push-buttons for menu navigation.

The skip timer control box shall have a full color, 4.3" screen. The color menu system shall provide an animated preview of skip timer patterns, reflecting current settings and switch positions and shall provide guided calibration processes for distance and pump calibrations. The color menu system shall have a descriptive information system to provide the operator with information about errors, warnings, and skip timer operation. There shall be a switch test menu, for infield diagnosis of switch failure, incorporated into the color menu system.

The skip timer system shall communicate using CAN bus serial communications protocol. It shall have an operating temperature range from 33°F to 140°F and a storage temperature range of 10°F to 160°F.

The skip timer output boxes shall directly drive all loads (air dusters, material guns, bead guns, double drop bead guns, etc.), and shall have drive current ratings of five (5) amps per channel. All outputs shall be solid state. To simplify diagnostics, the skip timer output boxes shall have driver indicator LEDs for all driver outputs. The skip timer shall accept up to five pump stroke inputs.

The skip timer shall accept motion signals from a magnet wrapped driveline collar. All motion signal sources will maintain a 0.25" resolution during normal road marking operations. The skip timer system software shall be field upgradeable via USB drive. The skip timer system hardware shall be field upgradeable using hub expansions ports for adding more driver output boxes, sensor input boxes, or data logging equipment.

The skip timer shall separately track skip and solid distance painted per gun, into internal, non-volatile counters.

SPECIFICATIONS
A-48-DH

I. GENERAL TRUCK SPECIFICATIONS: (Continued)

E. PAIN T MACHINE OVERVIEW: (Continued)

11. SPRAY EQUIPMENT:

The paint spray guns shall be Kamber Model 50-A airless type, capable of processing paint in quantities which will yield a 4 inch and 6, 8 inch (adjustable on the fly) wide line of 0.015 inches (15 mils) wet film thickness, and be put down at speeds of 5 to 20 MPH, 15 MPH being the target speed.

The paint guns shall have an air powered opening and air powered closing with a spring assist of the gun with a built in exhaust port on the gun to ensure immediate and complete shut off of the gun. (No exceptions) This guarantees a flat beginning and end to the line.

Each paint gun shall have a Reverse-A-Clean Tip and a fixed tip shipped with the truck.

Line blowers – Shall be installed at the front of each row of guns. Manufacturer's standard.

12. PAIN T TANKS:

This machine shall have paint storage capacity of a minimum 1000 GAL in an un-pressurized container designed for two-color paint application.

One compartment baffled for yellow, minimum 600 GAL.

One compartment baffled for white, minimum 400 GAL.

The entire top of each compartment shall be painted (Tape is unacceptable) with anti-skid surface to prevent foot slippage when wet or damp.

A Bustin type steel tread stepladder with handrails covered in anti-skid paint (Tape is unacceptable) shall be affixed to the platform side of the paint compartment for access to the inspection lids.

Liquid Level Calibration Rod - Two inverted aluminum direct reading rods calibrated in gallons shall be provided to indicate the paint quantity in each paint compartment. There shall be provisions made to store these rods vertically for traveling with a removable paint cup catch basin.

The container shall be constructed of minimum 10 gauge, 300 series, and stainless steel sheet.

Appropriate baffling shall be installed inside each compartment.

The bottom of the container shall be constructed of .1875 inch type 300 series stainless steel sheet sloped to allow drainage from each compartment.

The internal structure of the paint tank shall include removable stainless splash plates beginning a minimum of 2 inch from the top of tank.

The two compartments shall be fitted with individual removable top inspection openings.

Minimum diameter of the inspection opening shall be nine (9) inches.

The top of the storage containers shall be removable for ease of cleaning.

There shall be holes cut into internal baffles to facilitate pressure equalization.

There shall be 6 inch remaining at the top of the tank providing a splash area for sudden stops thus preventing paint from getting on lid gaskets or splashing on the platform.

Stainless steel formed channel, horizontal bracing shall include 10 gauge, 1.750 inch x 20 inch, gussets spaced approximately 10 inches between the formed channels, and fitted with a removable top.

Provisions shall be made for recirculation of heated paint in and out of each paint heater. The system shall include stainless steel valving and gauges to regulate the recirculating flow from the rear control panel.

The material supply system shall be so arranged as to permit the simultaneous operation of one to four spray guns on the left carriage and one or two spray guns on the right carriage.

There shall be a shelter operated emergency paint shut-off for the paint supply.

SPECIFICATIONS

A-48-DH

I. GENERAL TRUCK SPECIFICATIONS: (Continued)

E. PAIN T MACHINE OVERVIEW: (Continued)

13. PAIN T STRAINERS:

A stainless steel strainer shall be inserted in each low pressure paint system. The strainer shall have a cylindrical clean out with a pipe threaded sealed cap type in design and made from a #16 gauge perforated stainless steel material. The perforation shall be 1/8 inch in diameter and on approximately 3/16 inch centers (33 holes per square inch). No wire strainers are acceptable. The strainer shall easily accessible and where necessary, valving shall be provided to isolate the strainer from the feed line for cleaning.

The strainer assembly shall be connected to the paint supply lines by means of a union coupler. Valving shall be provided to isolate the strainer from the feed line for the cleaning of all piping, strainer, valves, and clean out fittings. The intent of this submission is to ensure that the paint machine is plumbed such that: all valves are readily accessible to operators, a clean out fitting is provided at each junction and strainer clean outs are conveniently located for periodic maintenance.

At the high-pressure outlet port of each high-pressure paint pump, there shall be high capacity, high pressure paint filters, and two guns per filter.

14. PAIN T FILL / SUPPLY PUMPS:

Two air driven pumps, one for white and one for yellow shall be furnished to transfer paint at the rate of 25 GPM from the storage containers to the paint tanks on the striping unit. The pumps shall be model "Wilden" PV-800(**no substitute, standardization**). Proflow anti stall air diaphragm type using stainless steel wetted parts. The pump housing shall be of stainless steel. The pumps shall be plumbed for 1 inch pipe and equipped with Neoprene diaphragms and quarter turn bolted type ball valves.

The pumps shall be supplied with mufflers.

There shall be an additional oiler line and filter to dissipate moisture in the pump.

Valve seats and clamp bands shall be stainless steel.

Pumps shall have stainless steel wing-nuts included at all accessible connections available.

The pumps shall be mounted at a highly accessible location and plumbed by means of unions (barbed fittings with hose clamps will not be accepted) to provide pump repair, replacement or clean out of the suction and discharge hoses.

The quick attach system must be provided for both pumps, to be removed from both sides.

The "loading" pumps shall double as priming pumps for the heat exchangers in the paint heating system.

Two (2) 12 foot sections of 2 inch diameter suction hose shall be supplied with quick disconnect fittings, caps and plugs.

There shall be two locations for pump shut off, one (1) ground level, and one (1) on platform by tanks.

Location of pump shut off and hose storage tank to be determined at the pre-build meeting.

SPECIFICATIONS

A-48-DH

I. GENERAL TRUCK SPECIFICATIONS: (Continued)

E. PAINT MACHINE OVERVIEW: (Continued)

14. PAINT FILL / SUPPLY PUMPS: (Continued)

Two (2) air driven, ARO 15 GPM @ 1500 psi airless pumps, one for yellow, one for white shall be provided and plumbed to deliver paint to the spray guns.

A minimum two quart high pressure surge tank shall be incorporated into the paint plumbing design after each high pressure pump. This accumulator tank shall minimize any hour-glassing of the painted line on the road.

The pumps shall have means to control the paint pressure to provide the required line width and wet film thickness of .012 inch to .015 inch. When operating in the range of 10 to 20 MPH.

A grounding strap shall be installed on the vehicle to discharge any static electricity build-up from the airless pumps.

15. GLASS SPRAY EQUIPMENT:

The glass guns shall be Kamber Model 90HO, except the diffuser (shroud) shall be chrome-plated and mounted behind the paint spray guns.

Gun outlet shall be fitted with a closed spooned glass deflector with adjustable side curtains to insure precise adjustment of beads on the paint line, thus minimizing waste of glass outside the paint line. The closed spoon material deflector must also be equipped with a hardened steel replaceable insert (either circular or rectangular shaped) to prevent wear of the deflector at the material outlet.

The glass guns atomizing air by-pass (coupling tube assembly) must be constructed of brass (plastic will not be acceptable). This assembly must also house a filter screen to prevent glass beads from being trapped in the atomizing air system.

In order to prevent glass from migrating into the air operation chamber, the gun shall employ a dual sealing system; this shall consist of a wiper seal, backed up by a needle "O" ring. The gun must also be equipped with internal stainless steel springs to prevent rusting due to condensation within the gun.

All gun inlets must be threaded (not soldered) to allow replacement of such parts due to wear or other damage. The automatic sphere guns shall be capable of dispensing 35 LBS of spheres per minute with 40-60 LBS air pressure on the glass tank.

The bead guns must face rearward and be mounted in a vertical position as close to the paint guns as possible while allowing room to work on all guns.

To ensure the proper angle of entry of the glass sphere spray into all types of fast-dry paint spray and to ensure maximum sphere dispersion and retention the distance between the spray gun orifice and sphere gun orifice must be adjustable forward and rearward.

The glass guns must be equipped with an interchangeable material tip system. This system must offer six different tips sized from 5mm to 10mm tip orifice dimensions to provide the operator an infinite range of application speeds. Tips must be constructed of hardened steel to prevent excess wear.

The spray equipment shall be controlled by means of solenoid valves and toggle switches mounted in lightweight, portable control boxes, assembled in such a manner that various standard line combinations can be obtained by one, but not more than two toggle switches. The glass guns shall be coordinated with the binder guns for simultaneous operations to provide complete coverage to the paint line as the vehicle speed varies.

An individual control switch shall be incorporated in the glass system for independent operation of each glass gun. An emergency recessed shutdown switch activating a ball type valve through an air-operated cylinder shall be mounted within the reach of each operating station, or a single system "main valve" shutdown system.

Solenoids shall be mounted in a way to provide easy accessibility.

There shall be air regulators for each individual glass bead gun mounted on the carriage with easy accessibility.

SPECIFICATIONS

A-48-DH

I. GENERAL TRUCK SPECIFICATIONS: (Continued)

E. PAIN T MACHINE OVERVIEW: (Continued)

16. GLASS SUPPLY:

One (1) A.S.M.E. pressure vessel shall be supplied having a minimum total capacity of 7,000 LBS of glass spheres.

The container shall be tested for 110 PSI working pressure; hydrostatically tested at 165 PSI. Be of all steel construction and shall have a top opening not less than 24 inch diameter. It shall be equipped with an air release valve, a 0-160 PSI pressure gauge and a 110 PSI pressure relief valve. Pressure vessel shall be piped in such a way as to insure that total capacity can be utilized. A filter shall be sized (volume) at system requirement plus 50% to allow for quick delivery.

A vacuum glass fill unit having a minimum capacity of 250 LBS of glass per minute, under a 20 in/50cm suction lift at 20% humidity with dry beads. By creating a vacuum in the glass tank, glass shall be drawn into the tank without contaminating the vacuum unit. The glass spheres shall be conveyed under pressure to automatic glass sphere dispensing guns through rubber pressure hoses. A heavy-duty self-evacuating oil and moisture remover shall be installed in the airline after a finned after cooler extending from the compressor to the air control center.

The glass filling system on this unit shall include a 2 inch I.D., 16 foot long fill hose with all the necessary fittings, including quick disconnect fittings and cover caps when not in use.

Each bead manifold shall have an end cleanout plug of at least 2 inch in diameter.

There shall be a bead shut-off valve (quarter turn) at the manifold for each bead gun.

There shall be a minimum 1 ¼" inch I.D. line from compressor to jet pump to allow for increased vacuum for beads.

There shall be a bead exhaust muffler system mounted in a way, not to interfere with the spray operation and away from personnel.

17. SPRAY GUN CARRIAGE ASSEMBLIES:

Two-gun carriage assemblies shall be supplied, mounted behind the vehicle's rear wheels to support and align the spray guns.

The main carriage, mounted on the left side of the vehicle, shall have provisions for attaching six (6) single color spray guns, and three (3) glass sphere guns.

A pneumatic lift cylinder electronically controlled from the operator's position shall be used to raise the carriage and a safety chain shall be installed to support it during transporting.

Carriages shall be open, adjusted to provide maximum ground clearance.

Trucks shall be able to paint 4 inch and 6-8 inch (adjustable on the fly) wide lines.

The cross slide supporting the carriages shall allow the carriages to be positioned for transport within the width of the vehicle platform, and permit its use anywhere from this location outward for a distance of 60 inches. The slide mechanism shall consist of a square tube within a square tube telescoping design with adjustable UHMW, self-lubricating material bearing areas. The outer tubing shall contain a two-channel bearing material configuration, mounted on a retainer, which will permit adjustment as the material wears. The inner slide will have four pads of the UHMW material bolted and shimmed to its innermost slide section. The pads shall allow shimming of the pads, as the pads wear, without disassembly of the slide. Both left and right carriages shall be steering wheel controlled. Each carriage slide shall be equipped with a hydraulic cylinder for moving the carriage to any point within its operating range. The cylinder shall be double action, controlled by a power steering control, and controlled by a steering wheel with check valves.

SPECIFICATIONS
A-48-DH

I. GENERAL TRUCK SPECIFICATIONS: (Continued)

E. PAIN T MACHINE OVERVIEW: (Continued)

17. SPRAY GUN CARRIAGE ASSEMBLIES: (Continued)

Steering wheels shall be centered (side to side) with the operator's seats, and adjustable (front to back) to conveniently locate it for the operator without moving the seats forward or backwards.

Left carriage shall have two 4:10 X 3.50 X 6 wheels, mounted on a single caster axle, at the front of the carriage. It shall support the carriage and maintain it at a fixed height from the road surface. A parallel system shall connect the carriage to a cross slide and maintain the spray guns normal to the road surface at all times.

The second spray gun carriage shall be provided and mounted on the right side of the striping unit approximately on the same lateral axis as the main carriage to align and support four (4) single color spray guns and two (2) glass sphere guns. The design of this carriage shall also extend 60 inch from the edge of the platform.

Two 4:10 X 3.50 X 6 wheels, mounted on a single caster axle, mounted on the right front carriage and shall support the carriage and maintain it at a fixed height from the road surface.

Hydraulic power for the operation shall be supplied by a high pressure hydraulic pump driven by the auxiliary engine. Each side is to work independently as to not create a hydraulic bind.

Stacked body, quick acting solenoid valves with a manual override feature shall be mounted on each carriage. Valves shall be equipped with balanced spool design to minimize back pressure or restriction in exhaust. The valves shall be of a one-piece aluminum design body and mounted inside a weatherproof steel box with a removable lid for servicing.

All bearings or pivots on the carriage, linkage or slide, where relative motion occurs, shall be fitted with replaceable, anti-friction bearings or replaceable bearing and pressure lubrication fittings.

With both carriages extended a span of 17 feet between the inner edges of the two lines shall be obtained. Each carriage shall be provided with L.E.D. safety lights (amber –forward, red - rear).

Tandem guns that will turn on automatically at an operator set MPH (Front-Both-Rear).

LEFT CARRIAGE			BERM CARRIAGE		
A	A			A	AIR NOZZLES
W(6")				W(4")	PAINT GUNS
W(6")				W(4")	
Y(4")	Y(4")			W(6")	PAINT GUNS
Y(4")	Y(4")			W(6")	
G(6")				G(4")	GLASS GUNS
G(4")	G(4")			G(6")	

SPECIFICATIONS
A-48-DH

I. GENERAL TRUCK SPECIFICATIONS: (Continued)

E. PAIN T MACHINE OVERVIEW: (Continued)

18. HEATING SYSTEM - PAINT:

The paint heating system shall be capable of maintaining a paint temperature of 120° Fahrenheit at the paint spray guns, at an ambient temperature of 70° Fahrenheit.

The heat source shall be a heat exchanger which extracts heat from the air compressor engine cooling water.

The paint heating system shall include two shell and tube type heat exchangers, having stainless steel tubes, and end bonnets. They shall be 4-pass type units each having a minimum heat transfer area of 64 square feet. Individual structural steel brackets shall be provided for mounting the exchangers in a vertical position. Aluminum covers shall be provided for each heat exchanger.

A separate intermediate heat exchanger shall be incorporated into the heating system to eliminate the possibility of paint contamination in the coolant system of the air compressor engine.

The manifold shall be mounted in a vertical position and not located over any operating part of the machine so that no paint will fall on a component during the draining and cleaning of the strainers in the manifold.

Three, 12-volt, DC electric motor driven circulating pumps shall be provided. The pumps shall have a minimum rating of 25 GPM when pumping the heated water/ethylene glycol solution. The pumps shall control:

PUMP A: Circulation to the white paint heat exchanger

PUMP B: Circulation to the yellow paint heat exchanger

PUMP C: Recirculation system.

A digital thermostatic heat control shall monitor the paint temperature in each heat exchanger. These controls shall turn off or on the pump feed to the heat exchangers on the temperature setting required by the paint manufacturer.

Incorporated in the water/glycol system will be an expansion tank at a convenient location to either fill or check the fluid level of the system. A 14 pound automotive type pressure cap shall be used to regulate the system. An overflow tube from the cap neck down through the platform shall safely vent any over flow to the ground.

Three (3) automatic air vents shall be installed in the heating system to vent any excess air that gets trapped into the heating system. One air vent shall be in the expansion tank line and one on each heat exchanger. (MANUAL AIR VENTS WILL NOT BE ACCEPTED).

SPECIFICATIONS

A-48-DH

I. GENERAL TRUCK SPECIFICATIONS: (Continued)

E. PAINT MACHINE OVERVIEW: (Continued)

19. PIPING / VALVES:

All plumbing on the low-pressure side shall be constructed of industrial style, stainless steel, 2" tube process-clamp type piping, fittings and quarter turn, bolted ball valves, with at least one-bolt clamp on the low-pressure side. All elbows shall be smooth 90° long radius style. Use of pipe thread fittings shall be minimized. Any high-pressure hoses will be rated to adequately provide a proper safety margin for high pressure spraying operations.

All plumbing on the high-pressure side shall be schedule 80 stainless steel threaded plumbing with full port quarter turn, bolted ball valves.

All hoses, pumps, fittings and valves that are in contact with the traffic paints shall be impervious to any petroleum based or water based solvent capable of constant pressures to 600 psi. Paint plumbing shall be stainless steel. Valves will be quarter turn ball type with Teflon seals, and valve construction on the low-pressure side shall be stainless steel with 4-bolt construction.

All piping, tubing or hosing used on the vehicle shall be firmly attached to the frame or bed, except where flexible conduits are required for proper operation or service. Non-rigid paint conductors shall be flexible Teflon solvent resistant material of at least .375 inch ID and shall be capable of withstanding pressures up to 200 PSI.

Additionally all nipples, plugs, reducers shall be stainless. Insulated piping between the pump and heat exchanger shall be 2 inch (min). Nylon braided Teflon lined hosing shall not be incorporated. Hard pipe with insulation shall be used.

All external-atomizing airlines shall be at least .3750 inch Teflon or nylon tubing.

The pumps, hoses, fittings, valves and all components that are in contact with the marking materials, solvent trays, water tank(s) and lines shall be stainless steel and impervious to the standard paint solvents, including: (1) V M & P Naptha, (2) Acetone, (3) Lactol Spirits, (4) Hexane, (5) Methyl Ethyl Keton and (6) Water.

The paint fill supply piping shall be furnished with 2 inch quick coupler male fittings and cover caps when not in use. Two 16 feet hoses with 2 inch standard pipe shall be furnished with female quick couplers on both ends compatible, with the male fittings. Female quick couplers shall be one piece.

All paint fills shall be at curbside.

Piping valves shall be designed for quick disconnect. All 2" valves shall be a full 2" inside dia.

Pipe threads shall be sealed with a soft type thread sealer to ease separation during service.

Quick disconnect connectors shall be utilized at the carriages.

20. AIR COMPRESSOR

The air compressor shall be a Boss DUS unit capable of supplying at least 250 cubic feet of free air per minute at 100 psi.

All containers shall be A.S.M.E. approved for 100 psi working pressure. All necessary safety valves, piping and fittings shall be included.

The compressor engine shall be diesel powered, liquid-cooled, four-cycle, four cylinder, overhead valve construction, heavy duty industrial type. It shall include as standard equipment: a fin-tube type radiator, lubricating oil filter, 12 volt electrical system, pushbutton starting, and recommended air filter to be shared with the compressor air intake. The air compressor engine and chassis engine shall have a common fuel tank.

The compressor shall have an external mounted muffler to reduce heat buildup in the cabinet.

A heavy duty, high capacity water separator shall be installed in the air line after an 8 ft. long finned after-cooler.

SPECIFICATIONS

A-48-DH

I. GENERAL TRUCK SPECIFICATIONS: (Continued)

E. PAIN T MACHINE OVERVIEW: (Continued)

20. AIR COMPRESSOR: (Continued)

A common skid base shall be provided under the engine and compressor so they may be handled and mounted as a package unit. The compressor shall be mounted to the platform longitudinal members. A complete cover with removable access panels shall be supplied for weather protection.

The operating control panel shall be located at the end of the compressor unit and the unit mounted so that it is at the curb side of the vehicle and include, in addition to operating controls, gauges showing oil and air pressures, water temperature, and voltmeter and an electric hour meter.

The unit shall also be furnished with the following accessory items as a standard part of the package: oil level gauge, automatic moisture trap for controls, automatic blow down valve, minimum pressure valve and a hydraulic pump.

This system shall be installed with all the fittings, brackets, clamps and hoses as per EQN-351A. The system shall be compatible with all fittings presently used by the Department. The Section Chief, Equipment Division, prior to installation shall approve the final placement of the male half of the snap coupler on the equipment.

There shall be a "FLOCS connections" decal to direct the operator.

21. CLEANER SYSTEM:

An air operated gun cleaning system shall be installed on the striping machine.

It shall consist of one (1) 40 gallon A.S.M.E. stainless steel pressure tank with safety valve and valves and piping necessary to introduce cleaner into each paint line.

A solvent injector system shall be piped into the paint hose after the main line valve at the outlet of the high pressure pump. This system must be as close as possible to the outlet of the high pressure pump to clean the paint manifolds and hoses for overnight storage.

There shall be a drain line for each tank one on left and one on right side of the truck.

All piping is to be solvent resistant type. The tank construction shall be with a 4 inch threaded top opening and a full steel skirt support. And mounted out of the rear operator's line of sight.

22. LED MESSAGE BOARD:

The striping unit shall have a full matrix, all LED, programmable message board that is changeable by a wireless controller located in rear shelter, 36 inch x 72 inch (approximate) in size, mounted on the rear area of the equipment platform.

The message board shall be capable of displaying messages in either alphanumeric text or symbolic graphic representation and has the capability of retaining in memory preprogrammed and user generated messages, MUTCD Part VI construction signs, and all arrow board functions.

The board shall be mounted in a fix horizontal position for operation.

The structural frame shall be at least 3 inch by 2 inch by 11 gauge rectangular tubing. The board shall be mounted so the highest point is less than 11 feet 6 inches from the ground.

For support, four mounting points shall be supplied, two on the rear of the platform and two on braces bolted to the platform railing.

- Message board manufacture must have a repair facility within the Commonwealth.
- Unit must be approved and listed for use on PA Bulletin 15.

SPECIFICATIONS
A-48-DH

I. GENERAL TRUCK SPECIFICATIONS: (Continued)

E. PAINT MACHINE OVERVIEW: (Continued)

23. LIGHTING/WARNING:

All lights provided on the paint body shall be LED and meet the Pennsylvania Motor Vehicle code and all wiring shall be run in vapor-proof type tubing with screwed junction box connections. Wiring shall conform in gauge and color with ATA standard. Turn signals, brake lights and rear warning shall be Whelen. Side marker lights and reflectors, as manufactured by Grote, shall be rubber shock mounted. No splices shall be made outside of a sealed junction box.

The location of this junction box/s for service access will be decided at the pre-build meeting.

Whelen Model # PADOTSY8 kit contains the following

- (1) R10PADOT R10-Mini Bar Warning Ref. EQN-120Q
- (2) M6AD M6-Amber Warning with Deutsch Connector - (rear shelter)
- (2) M6BTTD M6-BU with Deutsch Connector
- (2) M6BUWD M6-BU with Deutsch Connector
- (6) M6BRUSH M6-Brush Guards
- (4) LINZ6AD Linz6-Amber with Deutsch Connector - (2 in grill, 2 center/middle one each side of platform.
- (4) RGOMET Linz6-Grommet Kit
- (10) W441D –Harness side mating Deutsch connectors

Lights shall be mounted vertical in a row from top to bottom with M6AD M6-Amber Warning on top, M6BUWD M6-BU in middle and M6BTTD M6-BU at the bottom, to each side of rear shelter

(4) LINZ6AD Linz6-Amber shall be mounted, one to each side in front grill, and one to each side centered in platform. Ref. EQN-120Q

There shall be a Truck-Lite Model# 36140C LED license plate light with light bracket PN# 36710. (Installed) OEM/builder to provide remaining chassis/body harness and marker lighting shall be Grote, Trucklite or prior approved equal.

24. NIGHT LIGHTS:

Floodlights shall be LED. Switches shall be labeled and lighted to indicate when the light(s) are on.

Seven (7) 12V floodlights to illuminate the striper during night time operations. The lights shall be located as follows:

One (1) light located on the front of the truck cab, to illuminate the pointer, with control switch inside the truck cab.

Four (4) lights total, 2 on each carriage location one front and one rear. A switch for these lights shall be located in the rear operators control panel.

Two (2) lights inside rear operators cab one over each operator station.

1 – on front of rear shelter

1 – Telescopic pole mounted on compressor

25. HOSE REEL:

There shall be one 50 foot water hose reel, location to be determined at the pre-build meeting.

There shall be two 50 foot air hose reels, location to be determined at the pre-build meeting.

SPECIFICATIONS
A-48-DH

I. GENERAL TRUCK SPECIFICATIONS: (Continued)

E. PAIN T MACHINE OVERVIEW: (Continued)

26. SPARE PARTS:

- There shall be one (1) spare transfer pump
- There shall be two (2) spare spray system guns with tips.
- There shall be two (2) spare bead guns.
- There shall be two (2) spare regulator repair kit.
- There shall be one (1) spare interchangeable gun control boxes.

The successful manufacturer shall furnish a suggested parts stocking overview listing an essential parts inventory to support the field in areas of high turnover items frequently required to keep our units in an uptime mode.

27. MISCELLANEOUS ITEMS:

a. Equipment Identification:

All valves, switches, gauges and controls shall be labeled with permanent tags as to their function. There shall be a written operator's manual that shows all valve functions.

b. Decals and Signs (Tank):

The tanks shall have material warning decals on both sides to alert nearby personnel of tank contents and operational hazards. Paint white or yellow, solvent, beads, etc.

The truck shall have warning placards located on the front, back and both sides. All markings as required by HAZMAT Regulations shall be employed.

There shall be a permanent decal, 2 inch high red letters on white back ground affixed by the driver side door handle stating the overall maximum travel height of the completed and unloaded unit. (Example) HT-__' __" Ref. EQN-552.

There shall be a permanent decal, "Three Point Contact" located at each entry point of the truck cab and at the bed ladder area per EQN – 552-1. Exact location to be determined at pre build meeting.

SPECIFICATIONS
A-48-DH

I. GENERAL TRUCK SPECIFICATIONS: (Continued)

E. PAINT MACHINE OVERVIEW: (Continued)

28. Optional Data Logger:

If stated in the "Purchase Order", unit shall include data logger:

1. The Data Logger system shall connect directly to the Skip-Line brand Serial Timing System without additional wiring to the solenoids.
2. The Data Logger system shall utilize wireless communications from the peripheral sensors to the Data Logger.

- a. Wireless system used for ease of installation wiring, reliability, interchangeability.
- b. Only 12 volt power supply is required.

3. Each Data Logger will include all hardware and software needed for full operation to enable remote upload of all data. The system is not to be activated for remote viewing prior to delivery to the field. The receiving location, at their discretion, will be responsible for system activation and all subscription fees to enable a fully remote operating system. Upon activation the system will send live data to a secure hosted internet site for collection, storage, mapping, and report generation / viewing / file download:

- a. All data shall be password protected.
- b. Secure web-based back-up storage retention.
- c. Records can be stored indefinitely on the truck, pending viable cellular coverage areas.
- d. Mapping capability allows for web-based visual display of patterns painted, material usage, and application rates per section.
- e. Exception reporting for each section can be selected and printed.
- f. All reports can be saved or printed for future reference.
- g. Summary reports for end of day, job, week, month, year, are easily selected.
- h. Data from contractors can be required in compatible format for comparison and inspection.

4. Without activation, system will store data in database format, capable of creating reports including the following parameters:

- a. Total distance painted per pattern, per color, per side of the vehicle.
- b. Total gallons used per color.
- c. Total pounds of beads used.
- d. GPS coordinates and heading of each pattern change as well as regular interval reporting.
- e. Average vehicle speed while painting.
- f. Application rates per section:

- i. Gallons per mile (wet mil. thickness) per color.
- ii. Bead Pounds per gallon. (Pounds per mile, pounds per 100 sq. ft.)

- g. Metric / U.S. conversion
- h. Start time / Stop time, Date
- i. JOB name or number (Road number, route, section etc.)
- j. Calibration numbers for distance, gallons counts, etc. (All calibration numbers should be checked and verified regularly.)
- k. All reports capable of export to Excel (.xls) format via USB flash drive (thumb drive).
- l. All reports capable of export to CSV data format compatible with ESRI (GIS) import requirements.

SPECIFICATIONS
A-48-DH

I. GENERAL TRUCK SPECIFICATIONS: (Continued)

E. PAINT MACHINE OVERVIEW: (Continued)

28. Optional Data Logger: (Continued)

m. Data to be stored (sensors installed): will include the following.

- i. Average AMBIENT temperature
- ii. Average ROAD temperature
- iii. Average PAINT temperature per color

- iv. Average RELATIVE HUMIDITY
- v. Average DEW POINT

n. Data to be manually entered by operator

- i. Paint batch number (per color)
- ii. Bead batch number
- iii. Direction of painting
- iv. Notes
- v. Other parameters as required

5 The touch screen interface shall have integrated data logging software contained with its dedicated hardware. Laptop or PC base data loggers will not be accepted. The data logger shall receive all sensor and system data via CAN network. Direct sensing of pneumatic or actuator solenoids will not be accepted.

- a. Real-time application rates
 - i. Gallons per mile (per color/per gun
 - ii. Wet mil. Thickness (per color/per gun)
 - iii. Bead Pounds per gallon.
- b. Vehicle speed
- c. Tank volumes, and/or amounts used.
- d. Time and Date
- e. All sensor data.
- f. Operator input of JOB names/numbers.
- g. Operator input of manual data
- h. Operator entry of gun application width (For mil thickness calculations).

6. Additional equipment:

- a. System will have a second monitor for remote viewing; a 10 inch tablet to be installed in the chassis cab in a location that will allow the operator to clearly view the stripping operation information and data.
- b. Include an on-board printer capable of printing data reports on 8.5" x 11" plain paper for daily printouts, installed in the rear shelter.

SPECIFICATIONS
A-48-DH

II. DRAWINGS:

EQN-66	dated	Rev.	07-20-09	2 sheets	SPLASH GUARDS-RUBBER
EQN-66A	dated	Rev.	07-20-09	1 sheet	TRIANGLES AND STORAGE BOX
EQN-78	dated	Rev.	10-27-06	1 sheet	CB CONNECTORS
EQN-82D	dated	Rev.	07-22-15	1 sheet	CHOCK AND HOLDER
EQN-120Q	dated	Rev.	08-06-12	1 Sheet	UNIVERSAL TRUCK LIGHTING
EQN-122	dated	Rev.	06-30-14	sheet 1	DUMP BODY REFLECTIVE SHEETING
EQN-127A	dated	Rev.	01-02-09	1 sheet	CONSPICUITY
EQN-351A	dated	Rev.	06-19-13	2 sheets	FAST LUBE OIL CAHNGE SYSTEM
EQN-370-60"	dated	Rev.	07-11-13	3 sheets	PAINT TRUCK REAR SHELTER
EQN-501	dated	Rev.	06-08-09	2 sheets	CENTRALIZED LUBE SYSTEM
EQN-552	dated	Rev.	05-29-13	1 sheet	MAX. TRAVEL HEIGHT
EQN-552-1	dated	Rev.	03-23-15	1 sheet	THREE POINTS OF CONTACT STICKER

The above referenced drawings shall become part of these specifications.

These drawings reflect the intent of the Department and any discrepancies shall be resolved at the pre-build meeting between the vendor and the Specification Unit.

DRAWINGS APPEAR AT THE END OF THE SPECIFICATIONS.

SPECIFICATIONS
A-48-DH

III. MANUALS:

The successful vendor shall furnish all applicable manuals per unit in CD or USB flash drive (thumb drive) version:

- 1 Operator's
- 1 Parts – With original OEM part numbers
- 1 Service
- 1 Engine
- 1 Transmission (Automatic or Manual)
- 1 Body and Sub-frame (Parts and Service)
- 1 Complete set of manuals for any additional items/equipment added to a piece of equipment.
- 1 Electrical System Charts

The manuals listed shall be official O.E.M. publications supplemented with technical manuals for all components as published by sub-vendors/manufacturers.

Parts Manual presented must be a relative to "all" items utilized to build these units, with appropriate part numbers.

Delivery of these manuals shall be completed within a maximum of 90 days after the pilot model is accepted.

SPECIFICATIONS
A-48-DH

IV. TRAINING:

Mechanic:

The successful vendor shall provide services of qualified factory trained technicians for not less than 1 training session of not less than 7.5 hours at 1 PennDOT location to train personnel for in-depth preventive maintenance, overhaul and review of the proper usage of parts and service manuals, as well as component/system adjustments that need to be monitored at specified service intervals.

Operator:

The successful vendor shall provide services of qualified factory trained technicians for not less than 1 training session of not less than 7.5 hours at 1 PennDOT location to train personnel in the proper operation, safety and servicing of the equipment.

The successful vendor shall provide services of qualified factory trained technicians for not less than 1 training session of not less than 7.5 hours to train personnel on equipment functions while unit is performing a startup painting operation. "Ride along"

The successful vendor shall submit a training plan to the Fleet Management Division for approval within 45 days after receipt of the Purchase Order. The training plan shall consist of course outline and class schedule.

All training must be completed within 60 days after the dates established in the approved training plan unless an extension is mutually agreed to in writing by the Chief of the Fleet Management Division.

All training shall be coordinated with the District Equipment Managers, with the exception of Asphalt related training, which must be coordinated with the Statewide Training Coordinator (717) 787-4836, Fax (717) 783-4438.

SPECIFICATIONS
A-48-DH

V. WARRANTY:

Per PCID 1075: E.1. Construction Equipment - 2 years or 4000 hours whichever first occurs.

ENGINE WARRANTY:

The successful vendor and or supplying OEM shall provide the Department with a 100% parts and labor engine warranty for 60 months / 150,000 miles / 5,400 hours minimum. In addition to the engine warranty, the engine block shall be warranted against external perforation from corrosion for 60 months, 100% parts and labor.

NOTE: The oil pan shall be warranted against corrosion, rust, rust thru etc. regardless of atmospheric conditions for 60 months, 100% parts and labor.

EMISSION WARRANTY: The successful vendor and or supplying OEM shall provide the Department with a 100% parts and labor warranty for all emission related components to include the diesel particulate filter (DPF) for 60 months / 150,000 miles / 5,400 hours minimum. Shall be warranted against corrosion, rust, rust thru etc. regardless of atmospheric conditions.

RADIATOR WARRANTY:

Manufacturer service and warranty policy for radiator shall be for two (2) years, 100% parts and labor plus an additional three (3) years, 100% parts only.

TRANSMISSION WARRANTY:

Manufacturer service and warranty policy for automatic and manual transmissions shall be for 60 months 100% parts and labor.

BODY ELECTRICAL/LIGHTING:

Wiring harness shall be 5 years 100% parts. First year shall include 100% labor.

All LED lights shall be 5 years 100% parts.

NOTE: WARRANTY REPAIRS SHALL BE COMPLETED AT THE MANUFACTURER'S LOCATION OR IN-HOUSE FIELD REPAIR COMPLETED BY PENNDOT. IT SHALL BE THE DEPARTMENTS DISCRETION TO REPAIR INTERNALLY OR TRANSPORT THE UNIT TO THE DEALERSHIP. THE MANUFACTURER SHALL REIMBURSE THE DEPARTMENT AT THE MANUFACTURERS STANDARD PUBLISHED IN-HOUSE LABOR RATE. THE LABOR RATE SHALL BE MUTUALLY AGREED UPON BETWEEN THE DEPARTMENT AND VENDOR/BIDDER. ALL IN-HOUSE WARRANTY DOCUMENTATION SHALL BE DELIVERED WITH THE PILOT MODEL. ALL WARRANTY DOCUMENTATION SHALL BE DELIVERED WITH THE PILOT MODEL.

SPECIFICATIONS
A-B7-AX-A-AL

060900

TRUCK - CAB OVER (TILT CAB) - 37,000 LB GVWR (MIN), WITH POTHOLE PATCHER (060900)

INDEX

I. GENERAL TRUCK SPECIFICATIONS:

- A. Intent Statement
- B. Weight Distribution
- C. Power Train Overview
- D. Vehicle Components
 - 1. Alarm Backup
 - 2. Axle Front
 - 3. Axle Rear
 - 4. Brakes
 - 5. Cab-Tilt
 - 6. Chassis
 - 7. Lighting System
 - 8. Drive Line
 - 9. Electrical
 - 10. Engine
 - 11. Engine Accessories
 - 12. Exhaust
 - 13. Fast Lube Oil Change System (FLOCS)
 - 14. Frame
 - 15. Instrumentation
 - 16. Paint
 - 17. Steering
 - 18. Suspension: Front
 - 19. Suspension: Rear
 - 20. Tank - Fuel
 - 21. Tires
 - 22. Transmission

SPECIFICATIONS
A-B7-AX-A-AL

II. AUTOMATED POTHOLE PATCHER:

- A. Overall Dimensions
- B. Aggregate Hopper Body
- C. Aggregate Feeder
- D. Air Delivery
- E. Aggregate Delivery Hose
- F. Delivery Nozzle
- G. Air Filter
- H. Boom
- I. Hydraulics
- J. Emulsified Asphalt Delivery
- K. Power Takeoff
- L. Flush Tank
- M. Control Panel
- N. Arrow Board
- O. Heated Nozzle & Tank
- P. Body Cover
- Q. Tack & Crack Wand
- R. Spare Parts
- S. Safety
- T. Referenced Acceptable Model

III. DRAWINGS:

IV. MANUALS:

V. TRAINING:

VI. WARRANTY:

SPECIFICATIONS
A-B7-AX-A-AL

I. GENERAL TRUCK SPECIFICATIONS:

A. INTENT STATEMENT:

The purpose of these specifications is to describe a cab over (tilt cab) truck with single-rear-axle, two-wheel-drive, equipped with dual rear wheels and automatic transmission.

NOTE: Pennsylvania Department of General Services, PCID No. 1075, "*General Requirements for Bidding PENNDOT Vehicles/Equipment*", most current version effective at the time and date of bid opening, is included as a part of this specification. PCID No. 1075 may be reviewed and downloaded from the Department of General Services website, <http://www.dgs.state.pa.us>.

Delivery as required per Department of General Service PCID NO. 1075 Section "G". All units must be delivered within **270** days after receipt of the purchase order by the successful bidder.

B. WEIGHT DISTRIBUTION:

Weight slip must be submitted with the Pilot Model.

It is understood that the components specified are minimum and if the truck manufacturer's Engineering Department recommends or deems necessary, due to their particular weight distribution, a larger component or a large GAWR totally, the burden of responsibility is hereby placed upon the manufacturer's Engineering Department to supply a unit that is totally engineered.

1. Frame
2. Axle
3. Tires
4. Steering unit components
5. Rims
6. Suspension
7. Brakes
8. Any other items as required

The dynamic and static loads created by the unit, plus operational stresses, must be reviewed to ensure the Commonwealth of a properly designed/engineered unit.

The vehicle shall be certified for 37,000 LB Gross Vehicle Weight Rating (GVWR). The GVWR shall be identified in the cab or on the door as the final complete certification label (minimum rating).

C. POWER TRAIN OVERVIEW:

NOTE: LUBRICANTS FOR FRONT AXLE HUBS AND DIFFERENTIALS, AUTOMATIC TRANSMISSIONS, TRANSFER CASES AND ALL REAR DIFFERENTIALS SHALL MEET OR EXCEED ALL APPROPRIATE MIL AND SAE SPECIFICATIONS FOR SYNTHETIC LUBRICANTS AND SHALL HAVE ALL PLUGS IDENTIFIED AS SYNTHETIC OR PAINTED RED.

SPECIFICATIONS
A-B7-AX-A-AL

I. GENERAL TRUCK SPECIFICATIONS: (Continued)

C. POWER TRAIN OVERVIEW: (Continued)

The following power train components are acceptable in the noted combination.

ENGINE DIESEL-, MIN. 365 HP AT GOVERNED RPM, MIN. PEAK TORQUE OF 1,340 LB/FT TORQUE.

TRANSMISSION – ALLISION AUTOMATIC, 4500RDS 6 speed Series.
Automatic transmission cooler lines shall be stainless steel or a **preapproved** no-rusting material.

REAR AXLE – 23,000 LB. Min. DANA, Meritor or Mack in accordance with the specification.

NOTE: All rear axles must provide axle shafts with a minimum diameter of 2.19 inch at the spline.

NOTE: REAR AXLE/S SHALL HAVE AN EXTENDED BREATHER TUBE TO PREVENT DEBRIS BUILDUP.

SPECIFICATIONS
A-B7-AX-A-AL

I. GENERAL TRUCK SPECIFICATIONS: (Continued)

D. VEHICLE COMPONENTS:

1. ALARM - BACKUP:

Shall be an Ecco Back-up Alarm Model 450 with shock mounting (installed).

2. AXLE FRONT:

14,600 LB capacity, minimum. The front axle, drag links and tie rods shall have grease zerks installed.

3. AXLE REAR:

See POWER TRAIN OVERVIEW for acceptable axle. Magnetic drain plug.

NOTE:

Rear axle ratio selection will be made after the award and may be a mix of ratios as required.

4. BRAKE SYSTEM: Full air in compliance with the most current FMVSS requirements. The ABS shall incorporate a diagnostic fault switch that is capable of illuminating a fault light for diagnostic purposes. The switch shall be easily accessible and can be either dash or under-dash mounted. A dash-mounted display that will show all SAE message descriptions for the ABS is an acceptable means of diagnostics in lieu of the fault switch.

Rear Brakes: 16.5 inch x 7 inch "S" cam with quick-change type single or double pin. **(No substitute, standardization).**

Steer axle brake: Steer-axle-brake: 16.5 inch x 5 inch or a power front disc brake system providing equal performance. Quick-change type single or double anchor pin if drum type brakes are furnished.

Drum brakes shall have automatic slack adjusters and they shall be clearance-sensing type only, with adjustment on application of the brake. **(No substitute, standardization).** Backing plates shall be installed on all drum brakes.

Air compressor: Sized per manufacturer's recommendations.

Buzzer-type, low air pressure indicator.

Vehicle shall have a parking brake.

Air dryer: With heater, mounted away from road splashing and a minimum of 20 inches above road surface. Dryer shall be compatible with the body company clearance requirements for sub-frame, valve body, etc. Ref. Meritor Wabco 1800 with coalescing filter installation made in concurrence with the air compressor manufacturer's recommendations.

Air dryer shall be placed to accommodate the changing of filter cartridges without disconnecting any hoses or removing dryer base from its mounting location. Final mounting location shall be determined at Pre Build meeting (outside of frame rail). All electrical connectors for drain valve and air dryer shall be covered with heat shrink material or have sealed connections.

NOTE: Four (4) wheel disc brakes are acceptable.

SPECIFICATIONS
A-B7-AX-A-AL

I. GENERAL TRUCK SPECIFICATIONS: (Continued)

D. VEHICLE COMPONENTS: (Continued)

5. CAB:

Steel or aluminum cab stamped and welded, tilt cab.

Seats: The best air suspension driver seat available from OEM. Passenger seat non suspension. Bucket or Bench. Seat material shall be vinyl. All seating shall **have high visibility orange** seat belts.

Heater, manufacturer's highest output.

Tinted Safety glass throughout.

Dual sun visors.

Dual windshield defrosters.

Emergency triangle warning kit, with hold down.

KD-610-4645, KD Lamp Co. (Tel. (513) 621-4211), or equal, stowed (fastened) in the cab. There shall be a triangle storage bracket per EQN-66A mounted in the cab. Dual windshield wipers: Heaviest wipers, arms, motor and linkages available. Wiper blades, maximum length, shall follow windshield contours. Washer system shall be electric. Washer tank shall be a minimum capacity of one (1) qt. of washer fluid. It shall be filled with an anti-freeze type solvent.

Mirror(s) Drivers and passenger's side power mirrors. 6 inch x 16 inch, minimum, West Coast type with four (4) heavy duty extension arms. Mirrors and arms shall be stainless steel with mirror glass shock mounted and sealed. There shall be convex mirrors, rectangular 5.5 inch H x 8.5 inch W both sides. Arms, brackets and hardware shall be stainless steel, aluminum or chrome plated.

Air horn(s): minimum 1 with protective cover(s).

All controls and knobs shall be properly identified.

Inside dome light shall be provided.

Fenders: Front fenders shall have extensions to cover the width of the front tires.

Fire extinguisher: Rechargeable, with vehicle mount. Mounted in the cab for easy and quick access. Ref. 3A:40BC (5 LB).

Top of the first step shall be at a maximum of 22 inch above the ground.

Grab handles shall be supplied on all cab entry locations. Three points of contact shall be achievable at all cab entry locations. Handrails shall be coated with non-skid paint (non-skid tape is unacceptable) or have OEM anti-slip rubber inserts, both non-skid paint or rubber inserts must extend the full length of the grab handle.

Exterior grab handles shall be supplied if available from OEM.

There shall be a permanent decal, "Three Point Contact" located at each entry point of the truck cab and at the bed ladder area per EQN – 552-1. Exact location to be determined at pre build meeting.

AM/FM radio, with integral or individual clock.

Cab floor covering shall be heavy-duty rubber.

Air conditioning: manufacture's highest output.

Cruise Control

Drivers and passenger side windows shall be non-powered manually operated (sliding windows will not be acceptable).

Reflectivity enhancement per EQN-127

Anti-slip paint is required on all handholds, for the entire length, (tape is unacceptable) All handrails, ladders, and step configurations shall be built for three points of contact.

There shall be a permanent decal, 2 inch high red letters on white back ground affixed by the driver side door handle stating the overall maximum travel height of the completed and unloaded unit.

(Example) HT- __ ' __" Ref. EQN-552

SPECIFICATIONS
A-B7-AX-A-AL

I. GENERAL TRUCK SPECIFICATIONS: (Continued)

D. VEHICLE COMPONENTS: (Continued)

6. CHASSIS:

Cab-axle (CA) dimension: Shall be determined by the truck manufacturer and the body company.

Front Bumper: Mounted to the frame.

License plate bracket: Securely mounted with light.

ON BOARD GREASE SYSTEM Centralized on board chassis lubrication system installed.

Ref: EQN-501.

7. LIGHTING SYSTEM:

Whelen Light Kit Part # PADOTSY8, Kit contains the following lighting. EQN – 120Q

1 - R10PADOT Light Bar to be pedestal mounted on the driver's side. In no case shall the light bar be mounted on the roof of the vehicle.

2 - M6AD Amber warning lights with brush guard mounted to the rear of bed

2 - M6BTDD Stop, Tail, Turn lights with brush guard

2 - M6BUWD Back-up lights with brush guards

6- M6BRUSH Brush guards.

4 - LINZ6AD Amber warning lights, grommet mounted, flush mounted 1 to each side (middle/center) of bed and 2 flush mounted, equally spaced in the front Grill per EQN – 120Q. Warning lights are to be wired in conjunction with above light bar.

4 - LINZ6 Grommet Kits

10 - W441D Harness side mating Deutsch connectors.

The above lights are supplied with male and female Deutsch connectors that shall be utilized to connect the vendor supplied harness to each light source.

There shall be a Truck-Lite Model# 36140C LED license plate light with light bracket PN# 36710. (Installed)

Body builder to supply remaining marker and ICC lighting, they shall be protected against damage and shall also be shock mounted. Connections shall be water tight. All Body lighting shall be LED.

The Warning lights / Light bar shall have a lighted, permanently labeled toggle switch located in the dash.

Body wiring shall be Grote, Trucklite, or Prior Approved Equal.

There shall be no splices outside of a sealed box or fixture.

A color-coded electrical wiring chart and schematic shall accompany each body.

8. DRIVE LINE:

Main driveline: Spicer Life XL or Meritor MXL Series. "Factory balanced" greasable, (one zerk minimum).

Heavy-duty driveline shall be engineered and be compatible to engine, drive train and transmission torque. Heavy-duty center bearing, if required, with due consideration to drive shaft angles, length, location, proper bolting based upon engine and transmission selection. Inter-axle driveline: Spicer Life XL or Meritor MXL Series.

SPECIFICATIONS
A-B7-AX-A-AL

I. GENERAL TRUCK SPECIFICATIONS: (Continued)

D. VEHICLE COMPONENTS: (Continued)

9. ELECTRICAL:

Batteries: Two (2), heavy-duty, 12-volt. 1070.

Battery Mounting: It shall include the following:

- a.) 0.250 inch thick rubber shock pad under the battery.
- b.) Box with cover. Cover shall be constructed of fiberglass, poly, or aluminum (if aluminum, there shall be an insulating liner).
- c.) Mounting bolts, grade-8, with self-locking nuts.

Mounting of accessories within the battery box is prohibited. Fuses and circuit breaker shall be labeled.

Electrical system: Circuit-breaker-equipped in easily accessible location weatherproof Fuses are acceptable in circuit so identified by manufacturer as safety factor. Any fuse or circuit-breaker liable to be damaged during truck operation shall have an easily removable protective cover. All wire splices must be heat shrink material. Ref: Thomas & Betts Tel: (201) 707-2145.

Alternator: Delco 36SI (No substitute, Standardization) 160 A minimum, high performance, solid state (brushless).

Starter motor: Delco 39 MT (No Substitute, Standardization) with thermal over-crank protection and high torque capacity. Suitable for the diesel engines offered as per starter manufacturer's recommendation.

GPS Combo Radio Antenna: There shall be a pedestal mount base with built-in GPS, PCTEL model GPPB-204-54-12-S1-M1 and a low profile black antenna, PCTEL model BMLPU700. Assembly shall be mounted on pedestal with mini light bar, with the antenna cable routed to the front dash area between the seats towards windshield. There shall be a minimum of 1 feet of antenna cable coiled at the base of the dash to allow for connection to department radio. Antenna shall be prewired with a MINI - UHF MALE connection. (No substitute, standardization). No mounting in roof. REF. EQN-120Q

Power Distribution Center: There shall be a 4-way power/ground distribution center located on the underside of the dash for connection of department state radio. The lugs shall be configured in the following manner: (1) lug shall be a 30 ampere constant hot circuit, (1) lug shall be a 10 ampere ignition controlled circuit. (2) lugs shall be chassis ground. All connections shall be enclosed in a weatherproof enclosure.

Electrical wiring: Chassis and body wiring harness shall be protected at areas prone to cause chafing by installing convoluted plastic conduit and clamped using steel band clamps with rubber inserts.

Power supply for two-way radio: Dash mounted. Supplied at the dash. EQN-78

There shall be no wire splices outside of a sealed weatherproof box.

SPECIFICATIONS
A-B7-AX-A-AL

I. GENERAL TRUCK SPECIFICATIONS: (Continued)

D. VEHICLE COMPONENTS: (Continued)

10. ENGINE:

See POWER TRAIN OVERVIEW for acceptable engines.

Replaceable heavy-duty, full-flow type fuel filter(s) and oil filter(s) as recommended by the engine manufacturer, bearing a legible OEM part number.

Cooling system: The system shall be the largest factory engine cooling capacity, compatible with engines and transmissions referenced for continuous high engine output under extreme temperatures and/or operating conditions due to prolonged operation in low gears. The water pump shall be adequately sized to provide proper cooling and be of sufficient size to accommodate the larger pulley to adequately handle the specified options. Shall be fitted with provisions for visually monitoring coolant without necessitating removal of the cap from the radiator or expansion tank (e.g. sight glass, transparent expansion tank). The antifreeze solution shall meet all applicable EPA requirements. A non-charged spin-on coolant filter shall be installed if required by engine manufacturer.

11. ENGINE ACCESSORIES:

Automatic idle shutdown shall be set to five (5) minutes. An audible warning alarm shall be provided to alert operator prior to engine shutting down. Automatic idle shutdown shall be programmed to be overridden when the PTO Mode is engaged.

ECM shall be set to a maximum of sixty five (65) miles per hour.

Governor: Set at manufacturer's recommended maximum engine speed (rpm).

Engine Heater: Immersion in-block type for cooling flush-mounted in an accessible location at the outside the cab/hood. 115 volt, 3-prong plug. The electrical cable from the heater to plug shall be one-piece and waterproof.

Fan: Thermostatically controlled viscous type or manufacturer's recommended automatic fan.

Screening system: Mounted in front of radiator grill that protects radiator from stones and bugs. System to be approved by engine and truck manufacturer(s).

Air Cleaner: Air filter shall be manufacturer's heaviest air filter that meets all requirements of an extended engine warranty.

Diesel Fuel Filter: There shall be a DAVCO 382 or a 482 filtration unit installed and mounted (Higher than fuel tank) per manufactures recommendations in a location to accommodate filter replacements, yet be protected from road debris(**No substitute, standardization**). Mounting location to be determined at pre-build meeting.

Davco 382 Unit shall be equipped with engine coolant heat and 120 volt heater circuit. The 120 volt circuit and engine block heater shall be powered via the same electrical connection. (**No substitute, standardization**)

Davco 482 shall be equipped with a 12 volt and 120 volt heater circuit. 12 volt heater circuit will activate with the ignition key switch, the 120 volt heater circuit and engine block heater shall be powered via the same electrical connection. (**No substitute, standardization**)

OPTION: Engine shall be equipped with a minimum 2 stage, full engine compression brake, Brake lights shall activate when engine brake is activated Ref: Jacobs.

SPECIFICATIONS
A-B7-AX-A-AL

I. GENERAL TRUCK SPECIFICATIONS: (Continued)

D. VEHICLE COMPONENTS: (Continued)

12. EXHAUST:

DPF (diesel particulate filter) and exhaust system shall meet the latest EPA emission requirements.

Vertical tailpipe with elbow and muffler system or horizontal muffler and vertical tail pipe with elbow.

Exhaust system shall neither interfere with the operation of the body or equipment, nor shall it be close to any fluid tank. The tail pipe shall be installed in a manner that will keep the muffler and tail pipe away from body. The flex in the body, when operating on an uneven terrain, must be considered in the design. The DPF, muffler and tail pipe shall be shielded or insulated to protect personnel from burns when entering or exiting the cab. The shield shall be 180 degrees to 360 degrees and shall be of non-rust able material such as stainless steel or aluminum. Ref: Riker or equal.

13. FAST LUBE OIL CHANGE SYSTEM (FLOCS):

This FLOCS system shall be installed with all fittings, brackets, clamps and hoses. Hose from oil pan to FLOCS fitting shall be hydraulic hose with a 100R2 rating and properly secured. The system shall be compatible with all fittings presently used by the Department. The final placement of the male half of the snap coupler, on the equipment, shall be determined at the pre-build meeting. Ref: EQN-351A.

14. FRAME:

700,000 RBM (minimum).

No welding shall be done and no holes drilled on the main frame rails without approval of the frame manufacturer.

The vendor shall select main frame rails of adequate length to suit the body.

Underride protection per EQN-118.

Welded or bolted frame extensions are not acceptable.

15. INSTRUMENTATION:

All instruments illuminated and dash-mounted except where specified otherwise.

All standard instruments shall be supplied, including but not limited to the following:

Gauges: Oil pressure gauge.

Air pressure: gauge(s) for dual circuit, dual indicator pressure audible alarm.

Coolant temperature.

Fuel

Hourmeter, that records only when the engine is running, Ref: DATCON or equal.

Speedometer with odometer.

Tachometer

Voltmeter or ammeter

Parking brake indicator light.

SPECIFICATIONS
A-B7-AX-A-AL

I. GENERAL TRUCK SPECIFICATIONS: (Continued)

D. VEHICLE COMPONENTS: (Continued)

16. PAINT:

Cab shall be painted PennDOT yellow Ref: DuPont F9885, PPG 85246, Sherwin Williams 73266, Sikkens 4017 or NAPA 73266 for shade only. Frame and all underside components shall be painted black. Front bumper and plow frame shall be primed and painted black (with hardener) low VOC. All bare metal surfaces shall be coated using etching primer prior to paint. All surfaces shall be properly cleaned and prepared prior to paint, with all weld splatter and debris removed. Pothole patcher equipment shall be the same color as the cab. The side of the patcher shall have (both sides), entire length red/silver continuous backing 2 inch wide material. Reflexite Conspicuity 11 System or 3M Scotchlite Conspicuity Sheeting Series 980. Additionally, conspicuity tape shall be placed across the rear.

17. STEERING:

Dual integral or single integral type hydraulic power steering.
The pump shall not be the integral filter type unit.
Steering system (e.g. flow, pressure, relief valve etc.) shall be selected considering the full front-GAWR axle loading. Ref: ROSS or SHEPPARD gear assembly.)
Hydraulic supply pump, vane type or roller type supply pump with sufficient oil flow to permit one (1) steering wheel revolution per second with front axle loaded to rated capacity, in a "park" condition.
Power Steering Reservoir, "remote mounted", incorporating a filter which is easy to remove and replace. The remote filter referenced above shall be factory mounted.
The remote filter referenced above shall be factory mounted.
Glidecoat steering shaft, Bendix wedge lock lube-for-life shaft or ZF type steering shaft.

18. SUSPENSION: FRONT:

14,000 LB capacity at ground each front spring, minimum.

19. SUSPENSION: REAR:

23,000 LB capacity at ground each rear spring, minimum.

20. TANK - FUEL:

Safety - type fuel tank as per the requirements of FMVSS.
80 GAL minimum total capacity. **Dual Tanks are unacceptable.**
Heavy duty mounting straps with rubber shims/liners.
Tank Mounting Hardware and brackets shall be for "severe duty" applications. Heavy-Duty aluminum or stainless steel minimum 1.9-inch wide straps with rubber shims/liners shall be utilized.
Accessible fill pipe (located at either end of tank to avoid interference with steps).

SPECIFICATIONS
A-B7-AX-A-AL

I. GENERAL TRUCK SPECIFICATIONS: (Continued)

D. VEHICLE COMPONENTS: (Continued)

21. TIRES/WHEELS:

The truck shall be equipped with hub piloted steel disc wheels for tubeless tires. The wheel end shall be equipped with outboard cast brake drums, and 15 degree tubeless steel wheels, hub piloted, 10 hole - 285.75mm bolt circle with 22mm two-piece flange nuts.

Front: Wheels: 22.5 x 9.00, 10 hole - 285.75mm bolt circle with 220mm bore, tubeless steel disc wheel rated at 10,000 LBS at a maximum inflation pressure of 120 PSIG. Accuride part number 29039 or 50344PG. **(No substitute, standardization).**

Rear: Wheels: 22.5 x 9.00, 10 hole - 285.75mm bolt circle with 220mm bore, tubeless steel disc wheel rated at 10,000 LBS at a maximum inflation pressure of 120 PSIG. Accuride part number 28828or 50344PG. **(No substitute, standardization).**

The dual rear wheel/tire assembly shall have clearance between the tires, which permits the use of dual tire chains.

Wheel-Guard Separators: The wheel ends shall be equipped with the Accuride part number 5903 Wheel Guard Separator as follows:

Front axle - between the wheel and the brake drum.

Rear axle - between the inner dual and the brake drum and between the inner and outer duals.

Paint: The wheels shall be topcoat painted with TGIC Polyester Powder Paint MLD-82008 High Gloss Gray or equal applied over Cathodic Electro-Disposition Gray Primer.

Tires: All tires shall be radials.

Front Tires: 315/80R22.5 Min. Load range L

Rear Tires: 315/80R22.5 Min. Load range L

MANUFACTURER

Goodyear

Michelin

Bridgestone

FRONT TIRE

G-287 MSA

XZY3

M860A

REAR TIRE

G-287 MSA

XZY3

M860A

22. TRANSMISSION: See POWER TRAIN OVERVIEW for acceptable transmission.

Automatic transmission cooler lines shall be stainless steel or a **preapproved** no-rusting material.

SPECIFICATIONS
A-B7-AX-A-AL

II. AUTOMATED POTHOLE PATCHER:

A. OVERALL DIMENSIONS:

Length - Boom in travel position – maximum 24 feet (approx.)
Length - Boom down, retracted - minimum 30 feet (approx.)
Length - Boom down, extended – minimum 35 feet 5 inch (approx.)
Width - 85.5 inch (approx.)
Clearance Height - 12 feet (approx.)
Dimensions are approximate depending on truck application.

B. AGGREGATE HOPPER BODY:

Heavy gauge 5.0 cubic yard water level capacity, welded, hopper type with adjustable feed control turnbuckle on driver side. Air pressurized delivery for minimal moving and wear parts. Hinged steel lid for cover. Tarpolian lid.

C. AGGREGATE FEEDER:

Shall be an air lock system.

D. AIR DELIVERY:

4 inch x 6 inch high volume, low pressure, lobe-type blower with jack shaft drive from truck power take-off capable of producing 300 cfm (Transmission PTO).

E. AGGREGATE DELIVERY HOSE:

Acceptable hoses 3 inch I.D. Parker Super Flex 7363-3000 industrial material handling hose or 3 inch I.D. Boston Sabertooth H034748-100 industrial material handling hose, or preapproved equal. Aggregate hose shall be routed and secured to prevent low spots and run straight as possible to avoid excessive bends. Hose shall be protected at boom pivot point from pinching and hose collapse.

F. DELIVERY NOZZLE:

Steel mixing chamber with removable spray nozzles.

G. AIR FILTER:

Two stage, replaceable filter element dry-air cleaner.

H. BOOM:

One piece, double acting boom. Location, center front mount on .500 inch steel plate bumper, reinforced and welded. Quick lock hose clamps for delivery hose. Boom controls front mount - cab mounted electrical control by stick for boom extension, swing and hoist.

SPECIFICATIONS
A-B7-AX-A-AL

II. AUTOMATED POTHOLE PATCHER: (Continued)

I. HYDRAULICS: (Continued)

I. HYDRAULICS:

PTO operated. An electric-clutch operated system can be offered in lieu of a pony engine. If a pony engine is utilized; it shall be a water cooled engine.

Cylinders: (2) 3 inch x 16 inch double acting, single stage.
(1) 2.50 inch x 96 inch double acting, single stage.

Hose: Thermoplastic hydraulic hose - meets SAE spec. I00-R7.

2000 PSI working pressure. 8000 PSI burst pressure minimum.

30 GAL hydraulic reservoir with provisions to drain and clean at recommended service intervals. 10 micron, tank immersed hydraulic filter to withstand flows of 50 GPM at 100 PSI. Element replaceable through tank cover.

J. EMULSIFIED ASPHALT DELIVERY:

Air pressurized delivery at 60 PSI minimum. Petroleum resistant delivery hose with push-on fittings. 400 gal minimum horizontally mounted asphalt storage tank. ASME certified foam insulated tank and hoses. Heater element - 220 volt. Cab mounted asphalt delivery control valve. Fill opening shall be 8 inch diameter fill hole with safety cap. Delivery lines to have simple-to-operate cleaning/blow-out system.

K. POWER TAKEOFF:

Rated X-Heavy Duty 2 gear/single speed. Electric shift from cab control. Chelsea, 271 series, if applicable.

L. FLUSH TANK:

30 GAL air pressurized. To withstand 100 PSI mm. working pressure and stamped per ASME code Section 8, Division 1. Pressurized from vehicle air supply protected by priority valve and regulator valve.

M. CONTROL PANEL:

Cab floor mounted steel box type panel with easy driver access and driver positioning feature. Each function protected by push-to-reset circuit breakers.

SPECIFICATIONS
A-B7-AX-A-AL

II. AUTOMATED POTHOLE PATCHER: (Continued)

N. LED ARROW BOARD:

Intent Statement:

This specification is to provide minimum requirements for LED illuminated, self-contained, arrow panel which is to be used on a truck in the Commonwealth to direct and warn traffic of lane closures, roadway diversions and slow-moving maintenance operations. The purpose of these specifications is to describe a warning traffic control unit which shall consist of an all-weather sign panel containing illuminated directional arrow with indicators capable of being readily understood from a distance of one mile minimum during either daytime or nighttime operation. The unit shall be mounted on the rear of a vehicle and shall be remote-controlled from the cab. The unit shall be used on public streets and highways in the Commonwealth to direct and to warn traffic of lane closures, road diversions, and slow-moving maintenance operations. Only arrow panel models that have been reviewed in accordance with this specification and for which a Certificate of Approval has been issued by the Department shall be used or offered for sale or use on any public highway within the Commonwealth.

- Message board manufacture must have a repair facility within the Commonwealth.
- **Unit model must be approved and listed for use on PA Bulletin 15.**

Arrow Panel:

Arrow panel: shall be sandwich type and 15 lamps, LED, shall be mounted on it. Panels shall be fabricated from 0.063 inch thick aluminum sheets of grade 3003H14 riveted to 3 inch aluminum channels. An access panel shall be provided on the rear of the sign panel to allow access to any internal electronic components or wiring connections. The arrow board controller shall be contained in the arrow panel with a wired remote in the cab of the truck.

Weather Resistance: The arrow panel on which lamps are to be mounted shall be fabricated with adequate internal stiffening, and shall be sealed at the edges and all openings so as to be weather or water resistant, except weep holes shall be provided in the bottom of the panel to permit drainage of condensation.

Aluminum panels shall be etched and finished with a minimum of two coats of non-reflective flat black enamel on front and back surfaces.

Panels shall be 48 inch high x 96 inch wide (+/- 1 inch).

The perimeter frame and internal vertical members shall be from extruded aluminum alloy .250 inch thick x 3 inch x 1 inch, minimum, a minimum of two (2) spacers, maximum 30 inch apart. Internal cross members and/or stiffeners shall be heli-arc welded, or riveted using 1.5 inch x 1.5 inches x 3 inch aluminum angles with four (4) rivets minimum, per angle. The panel shall be adequately mounted and braced against vibration and shock.

The frame supporting the sign shall be fabricated from 2 inch x 2 inch steel tubing with a wall thickness minimum of .250 inch. The frame members shall be bolted or welded together.

SPECIFICATIONS
A-B7-AX-A-AL

II. AUTOMATED POTHOLE PATCHER: (Continued)

N. LED ARROW BOARD: (Continued)

Sign Lamps:

The lamp case shall have a weep hole to allow the escape of moisture. The lamp assembly of each LED lamp shall be so constructed and enclosed as to exclude moisture that would affect the specified operation of the light. The lamps shall be par 46 (5" diameter) LED. The lamp housing shall be constructed of high impact acrylic.

The LED lamps shall incorporate a pulse burst of white light prior to the amber flash. The white flash burst shall be on for 35 milliseconds and off for 50 milliseconds prior to the normal amber flash. The white flash shall be produced by 8 super bright LED's and not affect the normal MUTCD operation of the amber LED flash sequences.

The lamps shall be secured to the sign panel face by lamp hoods/visors via (4) four stainless steel screws, threaded into insertion nuts. The hoods shall be of high impact, UV protected, non-reflective, black plastic. Each hood shall have (4) four "keyhole" indexing mounting holes. The sign panel face shall be "notched" or indexed to mate with an indexing tab on each lamp to insure horizontal alignment of all lamps. The lamp hood shall circumscribe each lamp 360 degrees and extend outward from the sign panel face 5" to shade the lamps from sunlight. Each lamp shall incorporate a neoprene foam gasket between the lamp and the sign panel face to secure the lamp and prevent movement and protect against vibration.

Control and Circuitry:

The system shall incorporate an automatic, ambient light monitoring system to maximize system efficiency and reduce night time glare. Dimming for nighttime operation shall be 50% reduction in intensity to eliminate glare. The lamps shall be operated electronically. An automatic lamp intensity regulator shall keep the lamp output constant with varying battery voltages. The controller shall be enclosed in the arrow panel with an access panel for service. The remote shall be in the cab of the vehicle within easy reach of the driver.

All sign panel lamp wiring shall be protected to prevent damage to lamps or panel harness in the event of a short circuit. The remote shall be provide graphic lamp intensity and battery voltage display. The remote shall have an LCD display to indicate and verify mode selection and operation. The remote display shall show the operator a preview of the selected mode prior to arrow panel activation. **Instantaneous mode switching is not acceptable.**

The controller shall be, microprocessor controlled, touch pad, back-lighted for nighttime operation, and reverse polarity protected with audible and visual low battery alarm.

All wire, cable and other electrical components shall be properly sized/rated for the unit and its operations and shall be suitable for exposed outdoor installations subject to adverse weather conditions and ambient temperatures ranging from 125 degrees F down to -40 degrees F. Wiring and cable shall be UL approved for use under required operating conditions. All exposed junctions shall be waterproof and sealed against salt.

All exposed wiring shall be sheathed cable or be enclosed in looms or conduit and be routed to minimize chafing and interference. Short circuit protection shall be provided and the system shall be protected from overload by fuses or similar protective devices and be reverse polarity protected.

SPECIFICATIONS
A-B7-AX-A-AL

II. AUTOMATED POTHOLE PATCHER: (Continued)

N. ARROW BOARD: (Continued)

The board shall be capable of displaying all of the following modes:

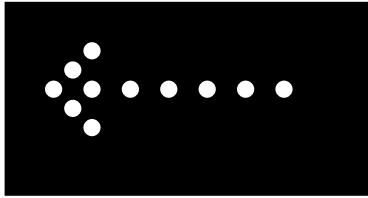

SINGLE FLASHING ARROW LEFT MODE

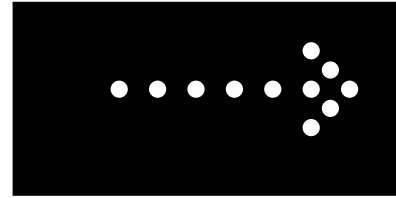

SINGLE FLASHING ARROW RIGHT MODE

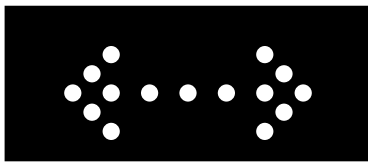

DOUBLE FLASHING ARROW MODE



CAUTION MODE

The caution mode may be either the four corner or bar or any other combination of four or more lamps arranged in a pattern which will not indicate a direction.

O. HEATED NOZZLE & TANK:

To use vehicle heat water heater by tapping into hose for warming source. It shall be insulated over length of exposed hosing. Tank shall maintain heat source.

SPECIFICATIONS
A-B7-AX-A-AL

II. AUTOMATED POTHOLE PATCHER: (Continued)

P. BODY COVER:

Hydraulically operated steel hopper lid or Tarpoleon Cover.

Q. TACK & CRACK WAND:

0.50 inch x 30 feet asphalt delivery line attached to normal equipment asphalt delivery at rear of body with hand-controlled valve at wand. Ability to flush delivery line by existing flush cistern.

R. SPARE PARTS:

1 hydraulic filter element, of each type installed.

2 spray nozzles.

1 two stage, air filter element.

S. SAFETY:

All patcher areas likely to be stepped or walked upon including patcher ladder and steps: Shall be aluminum, Bustin No. NST4 full size or Ohio Grating No. JA2119SG4 serrated or IKG Industries Type BS4 serrated swage lock, with end band. The size and strength shall be in accordance with the truck manufacturer's step design but the material shall be as noted above. The outer step edge must be serrated in lieu of plain, smooth metal edge. All edges shall be banded (skirting) on the outer perimeter. Overlay not acceptable. Top of the first step shall be (approximately) 21 inch above ground. Step design and material shall be the same design and material on the left and right side. All railings, hand holds and grab handles shall be coated with non-skid paint, for the entire length. Non-skid tape is unacceptable.

There shall be two wheel chocks per truck with a rope. EQN-82
Reflectivity enhancement per EQN-127

All necessary labels, decals and placards to meet Federal and Pennsylvania law shall be mounted accordingly.

Grab handles shall be supplied on all cab entry locations. Three points of contact shall be achievable at all cab entry locations. Handrails shall be coated with non-skid paint (non-skid tape is unacceptable) or have OEM anti-slip rubber inserts, both non-skid paint or rubber inserts must extend the full length of the grab handle.

Exterior grab handles shall be supplied if available from OEM.

There shall be a permanent decal, 2 inch high red letters on white background affixed by the driver side door handle stating the overall maximum travel height of the completed and unloaded unit.
(Example) HT-__' __" Ref. EQN-552.

There shall be a permanent decal, "Three Point Contact" located at each entry point of the truck cab and at the bed ladder area per EQN – 552-1. Exact location to be determined at pre build meeting.

T. REFERENCED ACCEPTABLE MODEL:

Schwarze Industries Road Patcher.

ROSCO Model, RA-300, meeting these specifications.

SPECIFICATIONS
A-B7-AX-A-AL

III. DRAWINGS:

EQN-66A	dated	Rev. 07-20-09	1 sheet	TRIANGLE STORGAGE BOX AND BRACKET
EQN-78	dated	Rev. 10-27-06	1 sheet	C.B. RADIO CONNECTIONS
EQN-82D	dated	Rev. 07-22-15	1 sheet	CHOCK AND HOLDER
EQN-118	dated	Rev. 06-26-09	1 sheet	UNDERRIDE PROTECTION
EQN-120Q	dated	Rev. 08-06-12	1 sheet	UNIVERSAL TRUCK LIGHTING
EQN-127	dated	Rev. 03-01-07	1 sheet	CONSPICUITY TAPE
EQN-351A	dated	Rev. 6-19-13	2 sheets	FAST LUBE OIL CHANGE SYSTEM
EQN-501	dated	Rev. 6-08-09	2 sheets	CENTRALIZED LUBE SYSTEM
EQN-552	dated	Rev. 5-29-13	1 sheet	MAX. TRAVEL HEIGHT
EQN-552-1	dated	Rev. 3-23-15	1 sheet	THREE POINT CONTACT

The above referenced drawings shall become part of these specifications.

These drawings reflect the intent of the Department and any discrepancies shall be resolved at the line setting ticket meeting between the vendor the Equipment Chief, or the pre-production inspection of the truck.

DRAWINGS APPEAR AT THE END OF THE SPECIFICATIONS.

SPECIFICATIONS
A-B7-AX-A-AL

IV. MANUALS:

The successful vendor shall furnish all applicable manuals per unit:

- 1 Operator's
- 1 Parts
- 1 Service
- 1 Engine
- 1 Transmission (Automatic or Manual)
- 1 Body and Sub-frame (Parts and Service)
- 1 Complete set of manuals for any additional items/equipment added to a piece of equipment.

The manuals listed shall be official O.E.M. publications supplemented with technical manuals for all components as published by sub-vendors/manufacturers.

Parts Manual presented must be a relative to "all" items utilized to build these units, with appropriate part numbers.

Delivery of these manuals shall be completed within a maximum of 90 days after the pilot model is accepted.

Manuals may be supplied on CD Disc in lieu of paper manuals.

SPECIFICATIONS
A-B7-AX-A-AL

V. TRAINING:

Mechanic:

The successful vendor shall provide services of qualified factory trained technicians for not more than 2 training sessions of not more than 15 hours at 2 PennDOT locations to train personnel for in-depth preventive maintenance, overhaul and review of the proper usage of parts and service manuals, as well as component/system adjustments that need to be monitored at specified service intervals.

Operator:

The successful vendor shall provide services of qualified factory trained technicians for not more than 2 training sessions of not more than 15 hours at 2 PennDOT locations to train personnel in the proper operation, safety and servicing of the equipment.

The successful vendor shall submit a training plan to the Fleet Management Division for approval within 45 days after receipt of the Purchase Order. The training plan shall consist of course outline and class schedule.

All training must be completed within 60 days after the dates established in the approved training plan unless an extension is mutually agreed to in writing by the Chief of the Fleet Management Division.

All training shall be coordinated with the District Equipment Managers, with the exception of Asphalt related training, which must be coordinated with the Statewide Training Coordinator (717) 787-4836, Fax (717) 783-4438.

SPECIFICATIONS
A-B7-AX-A-AL

VI. WARRANTY: Per PCID No.1075.

ENGINE WARRANTY:

The successful vendor and or supplying OEM shall provide the Department with a 100% parts and labor engine warranty FOR 60 months / 150,000 miles / 5,400 hours minimum. In addition to the engine warranty, the engine block shall be warranted against external perforation from corrosion for 60 months, 100% parts and labor.

NOTE: The oil pan shall be warranted against corrosion, rust, rust thru etc. regardless of atmospheric conditions for 60 months, 100% parts and labor.

EMISSION WARRANTY: The successful vendor and or supplying OEM shall provide the Department with a 100% parts and labor warranty for all emission related components to include the diesel particulate filter (DPF) FOR 60 months / 150,000 miles / 5,400 hours minimum. Shall be warranted against corrosion, rust, rust thru etc. regardless of atmospheric conditions.

RADIATOR WARRANTY:

Manufacturer service and warranty policy for radiator shall be for two (2) years, 100% parts and labor plus an additional three (3) years, 100% parts only.

TRANSMISSION WARRANTY:

Manufacturer service and warranty policy for automatic and manual transmissions shall be 60 months 100% parts and labor.

BODY ELECTRICAL/LIGHTING:

Wiring harness shall be 5 years 100% parts. First year shall include 100% labor.

All LED lights shall be 5 years 100% parts.

NOTE: WARRANTY REPAIRS SHALL BE COMPLETED AT THE MANUFACTURER'S LOCATION OR IN-HOUSE FIELD REPAIR COMPLETED BY PENNDOT. IT SHALL BE THE DEPARTMENTS DISCRETION TO REPAIR INTERNALLY OR TRANSPORT THE UNIT TO THE DEALERSHIP. THE MANUFACTURER SHALL REIMBURSE THE DEPARTMENT AT THE MANUFACTURERS STANDARD PUBLISHED IN-HOUSE LABOR RATE. THE LABOR RATE SHALL BE MUTUALLY AGREED UPON BETWEEN THE DEPARTMENT AND VENDOR/BIDDER. ALL IN-HOUSE WARRANTY DOCUMENTATION SHALL BE DELIVERED WITH THE PILOT MODEL. ALL WARRANTY DOCUMENTATION SHALL BE DELIVERED WITH THE PILOT MODEL.

SPECIFICATIONS
A-48-DO-A-AL

062300 - 062700

TRUCK - SPECIAL PURPOSE PONY
38,000 LB GVWR

TRUCK, PONY, 20' BODY (062300)

TRUCK, PONY, 24' BODY (062700)

INDEX

I. GENERAL TRUCK SPECIFICATIONS:

- A. Intent Statement
- B. Weight Distribution
- C. Power Train Overview
- D. Vehicle Components
 - 1. Alarm Backup
 - 2. Axle Front
 - 3. Axle Rear
 - 4. Brakes
 - 5. Cab
 - 6. Chassis
 - 7. Optional Engine Brake
 - 8. Drive Line
 - 9. Electrical
 - 10. Engine

October 12, 2016 GAW

SPECIFICATIONS
A-48-DO-A-AL

I. GENERAL TRUCK SPECIFICATIONS: (Continued)

D. Vehicle Components (Continued)

11. Engine Accessories
12. Exhaust
13. Fast Lube Oil Change System (FLOCS)
14. Frame and Frame Extension
15. Instrumentation
16. Paint
17. Safety
18. Steering
19. Suspension: Front
20. Suspension: Rear
21. Tank - Fuel
22. Tires
23. Transmission

E. Van Body

1. Body Dimensions
2. Body Material
3. Rear Door
4. Side Door - Curb Side and Street Side
5. Electrical
6. Floor
7. Accessories
8. Lift Gate
- 8a. Optional Trailer Tow Package (installed)
9. Roof

II. DRAWINGS:

III. MANUALS:

IV. TRAINING:

V. WARRANTY:

SPECIFICATIONS
A-48-DO-A-AL

GENERAL TRUCK SPECIFICATION:

A. INTENT STATEMENT:

The purpose of this specification is to describe a conventional dual rear wheel, single rear axle truck with a van body of various lengths.

NOTE: Pennsylvania Department of General Services, PCID No. 1075, "*General Requirements for Bidding PENNDOT Vehicles/Equipment*", most current version effective at the time and date of bid opening is included as a part of this specification. PCID No. 1075 may be reviewed and downloaded from the Department of General Services website, <http://www.dgs.state.pa.us>.

Delivery as required per Department of General Service PCID NO. 1075 Section "G". All units must be delivered within **270** days after receipt of the purchase order by the successful bidder.

B. WEIGHT DISTRIBUTION:

Weight slip shall be submitted with the Pilot Model.

Engineering Certified Weight Distributions (empty and loaded) shall be provided with the pilot model. These shall be reviewed to determine the weight distribution with "maximum legal" payload for the unit which is proposed.

It is understood that the components specified are minimum and if the truck manufacturer's Engineering Department recommends or deems necessary, due to their particular weight distribution, a larger component or a large GAWR totally, the burden of responsibility is hereby placed upon the Manufacturer's Engineering Department to supply a unit that is totally engineered.

1. Frame
2. Axle
3. Tires
4. Steering components
5. Rims
6. Suspension
7. Brakes
8. Any other items as required

The dynamic and static loads created by the unit, plus operational stresses, must be reviewed to ensure the Commonwealth of a properly designed/engineered unit.

The vehicle shall be certified for 38,000 LB Gross Vehicle Weight Rating (GVWR). The GVWR shall be identified in the cab or on the door as the final complete certification label (minimum rating)

SPECIFICATIONS
A-48-DO-A-AL

I. GENERAL TRUCK SPECIFICATION: (Continued)

C. POWER TRAIN OVERVIEW:

NOTE: LUBRICANTS FOR FRONT AXLE HUBS AND DIFFERENTIALS, AUTOMATIC TRANSMISSIONS, TRANSFER CASES AND ALL REAR DIFFERENTIALS SHALL MEET OR EXCEED ALL APPROPRIATE MIL AND SAE SPECIFICATIONS FOR SYNTHETIC LUBRICANTS AND SHALL HAVE ALL PLUGS IDENTIFIED AS SYNTHETIC OR PAINTED RED.

(The OEM shall provide written exemption if synthetic oil is not installed).

The following power train components are acceptable, minimum, in any noted combination: (Any deviations require, prior to bid, authorization by Chief of Equipment Division).

ENGINE DIESEL – ENGINE- CUMMINS ISL9 MIN. 320 HP AT GOVERNED RPM, MIN, 1,000 LB/FT TORQUE. SHALL MEET LATEST EPA EMISSIONS.

TRANSMISSION – AUTOMATIC ALLISION 3000 RDS, 6 speed. Automatic transmission cooler lines shall be stainless steel or a **preapproved** no-rusting material.

REAR AXLE – 23,000 LB. Min.

DANA S23-170
MERITOR RS23160
MACK - RA23

NOTE: All rear axles must provide axle shafts with a minimum diameter of 2.19 inch at the spline.

SPECIFICATIONS
A-48-DO-A-AL

I. GENERAL TRUCK SPECIFICATIONS: (Continued)

D. VEHICLE COMPONENTS:

1. ALARM - BACKUP:

Shall be an ECCO Back-up Alarm Model 450 with shock mounting.

2. AXLE FRONT:

16,000 LB capacity, minimum, "ROCKWELL or SPICER Model" or equal.

The front axle, drag links and tie rods shall have grease zerks installed.

Sufficient tire clearance at maximum turning angles.

Complete "STEMCO" or INTERNATIONAL oil seal assembly, including hub, window plug type and "GUARDIAN" or INTERNATIONAL seal, or equal.

Each unit shall have the front end aligned prior to delivery.

The front axle king pin bushings shall be the bronze type.

3. REAR AXLE:

See POWER TRAIN OVERVIEW for acceptable axle.

STEMCO or INTERNATIONAL rear wheel seals, or equal.

Magnetic drain plug.

ALUMINUM OR LIGHTWEIGHT HOUSING IS NOT ACCEPTABLE.

NOTE: Rear axle ratio selection will be made after the award and may be a mix of ratios as required.

The successful vendor/manufacturer shall present three (3) computer runs showing three (3) most likely candidates for consideration for a speed range up to 65 mph maximum and this information shall be presented at the pre-build meeting.

4. BRAKES:

16.500 inch x 7 inch "S" cam rear brakes with quick change type single or double pin. (No substitute - standardization).

16.500 inch x 6 inch "S" cam steer axle brake or a power front disc brake system providing equal performance. Quick change type single or double anchor pin if drum type brakes are furnished.

Full air antilock in compliance with the most current FMVSS requirements.

The ABS shall incorporate a diagnostic fault switch that is capable of illuminating a fault light for diagnostic purposes. The switch shall be easily accessible and can be either dash or under-dash mounted. A dash-mounted display that will show all SAE message descriptions for the ABS is an acceptable means of diagnostics in lieu of the fault switch.

If air compressor intake is connected to engine air intake an inlet check valve must be used.

SPECIFICATIONS
A-48-DO-A-AL

I. GENERAL TRUCK SPECIFICATIONS: (Continued)

D. VEHICLE COMPONENTS: (Continued)

4. BRAKES: (Continued)

Buzzer-type, low air pressure indicator.

Parking brake: Rear wheels, spring-type, MGM 30/30 or ANCHORLOCK 30/30 gold seal chambers (no substitute). Parking brake shall provide modulated emergency braking via the foot valve in the event of a rear service system failure.

Rear service parking brake chambers shall be front or top mounted.

Air tank: Automatic drain valve, on wet (first) tank. Each of the remaining air tanks shall have a manual drain valve.

Air dryer: With heater, mounted away from road splashing and a minimum of 20 inches above road surface. Dryer shall be compatible with the body company clearance requirements for sub-frame, valve body, etc. Per: Haldex DRYest or Bendix AD-IP installation made in concurrence with the air compressor manufacturer's recommendations.

Air dryer shall be placed to accommodate the changing of filter cartridges without disconnecting any hoses or removing dryer base from its mounting location. Final mounting location shall be determined at Pre Build meeting.

All electrical connectors for drain valve and air dryer shall be covered with heat shrink material or have sealed connections.

Brake valve shall be mounted away from road splashing.

All drum brakes shall have automatic slack adjusters, and they shall be clearance sensing type only (**no substitute**).

5. CAB:

Cab shall have air suspension system

Steel or Aluminum cab, 105 inch minimum to 116 inch maximum BBC (Bumper-to-Back-of Cab dimension).

Hood: Fiberglass, tilting.

Seats: Driver's seat shall be high-back, adjustable Bostrom Air 915 Series with lumbar support or National 2000 Series with lumbar support, with body cloth insert and three-point retractable seat belt (**Seatbelt shall be High Visibility Orange**). A protective skirt shall cover the seat suspension mechanism. No substitute on seat reference. Color to match cab interior. Seat shall have a fold-up armrest on the right side of the driver's seat.

Passenger seat: With three-point retractable seat belt (**Seatbelt shall be High Visibility Orange**). Manufacturers, high-back, non-suspension type. Color coordinated.

Note: If due to cab configuration a Bostrom 915 seat cannot be used, a Bostrom 910 may be substituted. All other requirements must be met.

Deluxe fresh air hot water heater and defroster, MANUFACTURER'S highest output heater.

Windshield: 1 or 2 piece construction. Tinted safety glass throughout.

Dual interior sun visors.

Air conditioning: manufacture's highest output.

Dual windshield wipers: Wipers and heaviest arms, motor and linkages available. Washer system shall be electric. They shall be two minimum (2) speed, intermittent.

Washer tank: Minimum capacity two (2) quarts of washer fluid and shall be filled with an anti-freeze type solvent.

SPECIFICATIONS
A-48-DO-A-AL

I. GENERAL TRUCK SPECIFICATIONS: (Continued)

D. VEHICLE COMPONENTS: (Continued)

5. CAB: (Continued)

Mirrors: Driver's and passenger side power mirrors, west coast style minimum 7 inch X 14 inch with manufacturer's standard heavy duty break away arms.

Mirrors shall be heated with a lighted toggle switch mounted within accessible reach of the operator, automatic on/off is acceptable. The wires shall be fitted in such a way that the mirror glass/element can be changed by unplugging the two-wire lead.

There shall be a heated convex mirror both sides, minimum 6 inch X 7 inch or 8 inch diameter.

There shall be a heated blind-spot elimination mirror (conventional cab only) mounted on the right front fender and it shall be minimum 7 inch X 7 inch or 8 inch diameter stainless steel or aluminum head with mirror. Mirror shall be a conventional convex mirror, and shall not be of the half-round cross view type. All arm/s and hardware shall also be stainless steel. Fender type washers stainless or aluminum, with rubber pads to be placed on both sides of the fender shall be included. Pedestal system shall be single, double or triple mounting assemblies (stainless steel or aluminum). Mirror shall be mounted in rubber or vinyl.

Drivers and passenger entrance steps: Shall be aluminum, serrated. The outer step edge must be serrated in lieu of plain. (Overlay is not acceptable).

Step design material must be the same both left and right side.

Ref: Bustin No. NST4 full size, Ohio Grating No. JA21195G4 serrated, IKG. Industries Type B54 or Mack Part # 85QM423OM4

Top of the first step shall be at a maximum of 22 inch above the ground.

Inside dome light shall be provided.

Air horn(s).minimum 1 with snow cover (unless mounted under hood).

All controls shall be properly identified.

AM - FM radio with weather band.

Cruise control.

The cab floor covering shall be heavy duty rubber with closed cell rubber or heavy felt backing.

The engine components facing wheel areas, on both sides, shall be shielded.

There shall be box mounted wind deflector of adequate size to offer minimum wind resistance and maximum fuel mileage. Deflector shall be bolted in place. Temporary attachment is unacceptable

Ref. Nose-Cone Part# NC38-RM2. Steering wheel diameter shall be 18 inch (approx.).

Manufacturer's Standard.

Air deflector: Clear colorless or smoke color, hood mounted. Deflector manufacturer's standard full width for the truck model. Access to front end hood tilt handle shall not be blocked. Extra handle acceptable. Ref: Deflect-Shield Corp., Tel. 1-800-247-2440.

Sun Visor: External, cab mounted. Reference section I. D. 16 Paint.

Power windows: Right and Left sides.

Grab handles shall be supplied on all cab entry locations. Three points of contact shall be achievable at all cab entry locations. Handrails shall be coated with non-skid paint (non-skid tape is unacceptable) or have OEM anti-slip rubber inserts, both non-skid paint or rubber inserts must extend the full length of the grab handle.

Exterior grab handles shall be supplied if available from OEM.

Fenders: Front fenders shall have extensions to cover the width of the front tires.

Steering wheel diameter shall be 18 inch (approx.), Manufacturers standard.

Steering Column: Steering wheel and column shall be tilt and telescopic, infinitely adjustable to multiple positions.

SPECIFICATIONS
A-48-DO-A-AL

I. GENERAL TRUCK SPECIFICATIONS: (Continued)

D. VEHICLE COMPONENTS: (Continued)

5. CAB: (Continued)

There shall be a permanent decal, 2 inch high red letters on white back ground affixed by the driver side door handle stating the overall maximum travel height of the completed and unloaded unit.

(Example) HT-__' __" Ref. EQN-552

There shall be a permanent decal, "Three Point Contact" located at each entry point of the truck cab and at the body ladders area per EQN – 552-1. Exact location to be determined at pre build meeting.

6. CHASSIS:

Cab-axle (CA) dimension: (Wheel base and CA dimension may be adjusted to provide the optimum legal weight distributions with maximum payload.)

The frame AF shall be reinforced by cross member(s) at the rear of the frame as required. (Local installation is acceptable.)

Heavy duty front bumper.

Lights: Mounted on the rear of the frame and recessed incorporating guards or protected by installation inside the frame.

Front mounted tow hooks or eyes: (2) two front.

License plate bracket: Securely mounted. (Front & Rear)

ON BOARD GREASE SYSTEM Centralized on board chassis lubrication system installed. Ref: EQN-501.

7. OPTIONAL ENGINE BRAKE:

Engine shall be equipped with a minimum 2 stage, full engine compression brake, Brake lights shall activate when engine brake is activated.

8. DRIVE LINE:

Main driveline: Spicer Life XL or Meritor MXL Series. "**Factory balanced**" greasable, (one zerk minimum). Heavy-duty driveline shall be engineered and be compatible to engine, drive train and transmission torque. Heavy-duty center bearing, if required, with due consideration to drive shaft angles, length, location, proper bolting based upon engine and transmission selection. Inter-axle driveline: Spicer Life XL or Meritor MXL Series.

9. ELECTRICAL:

Batteries: Two (2) or Three (3), heavy-duty, 12-volt, field maintenance-free, BCI Group Size 31, with stud-type posts and anti-corrosion treatment on each terminal (min 1850 CCA).

Battery Mounting: It shall include the following:

- a.) 0.25 inch thick rubber shock pad under the battery.
- b.) Box with cover. Cover shall be constructed of fiberglass, poly, or aluminum (if aluminum, there shall be an insulating liner).
- c.) Mounting bolts grade 8 with self-locking nuts.

Mounting of accessories within the battery box is prohibited.

Cables shall conform to RCC Practice 105 with "Sealed" terminal ends for stud-type battery posts.

Electrical system: Circuit-breaker-equipped, in easily accessible location, weatherproof. Fuses acceptable in circuit so identified by manufacturer as safety factor.

SPECIFICATIONS
A-48-DO-A-AL

I. GENERAL TRUCK SPECIFICATIONS: (Continued)

D. VEHICLE COMPONENTS: (Continued)

9. ELECTRICAL: (Continued)

Any fuse or circuit-breaker liable to be damaged during truck operation shall have an easily removable protective cover. All wire splices must be heat shrink material. Ref: Thomas & Betts Tel: (201) 707-2145.

Alternator: Delco 36SI (No substitute, Standardization) 160 A minimum, high performance, solid state (brushless).

Starter motor: Delco 39 MT (No Substitute, Standardization) with thermal over-crank protection and high torque capacity. Suitable for the diesel engines offered as per starter manufacturer's recommendation.

Battery cable from battery negative terminal to starter motor or frame.

Note: Starter shall have (OCP) either built in or controlled by the Vehicle's control system, (if required).

Alternator and starter mounting bolts: Grade 8.

Power supply for two-way radio: Dash or overhead console mounted. Both male/female ends shall be supplied, per EQN-78.

Electrical chassis-wiring harness:

Lights: All lights shall meet all Federal and State regulations. The head Lights shall be Halogen with (DRL's) daytime running lights manufacture's STD or aftermarket. Body lights shall have their own dedicated complete circuit. All lights shall be LED.

Whelen Light Kit Part # PADOTSY9 Kit contains the following lighting Ref. EQN-120T.

2 – 50R00XRD, 500 LED BTT

2 – 50C00WCD, 500 LED Back-up

4-5GROMMET

4- W441D Harness side mating Deutch connectors.

The above lights are supplied with male and female Deutsch connectors that shall be utilized to connect the vendor supplied harness to each light source.

There shall be a Truck-Lite Model# 36140C LED license plate light with light bracket PN# 36710. (Installed)

Body builder to supply remaining marker and ICC lighting, they shall be protected against damage and shall also be shock mounted. Connections shall be water tight.

Body wiring shall be Grote, Trucklite, or Prior Approved Equal.

There shall be no splices outside of a sealed box or fixture. All pass-through points shall be properly sealed and protected.

A color-coded electrical wiring chart and schematic shall accompany each body.

Flasher: (All) heavy-duty electrical, Ref: Tridon Model EL 12 or equal.

Note: If an audible alarm is supplied for 4 ways and turn signals, it shall have an on/off capability.

10. ENGINE:

See POWER TRAIN OVERVIEW for acceptable engines.

Replaceable heavy-duty, full-flow type fuel filter(s) and oil filter(s) as recommended by the engine manufacturer, bearing a legible OEM part number.

Cooling system: The largest factory available capacity compatible with engines and transmission referenced. With overflow recovery system and visual level indicator.

Radiator core and shell: Heavy-duty design.

The oil dipstick must have tubing and dipstick of sufficient length to provide reasonable access for checking the oil level.

SPECIFICATIONS
A-48-DO-A-AL

I. GENERAL TRUCK SPECIFICATIONS: (Continued)

D. VEHICLE COMPONENTS: (Continued)

11. ENGINE ACCESSORIES:

Engine Heater: Immersion in-block type for cooling system with waterproof plug flush-mounted in an accessible location at the front/roadside of the vehicle outside the cab/hood, 115 volt, 3-prong plug. The electrical cable from the heater to plug shall be one piece and waterproof.

Coolant filter: Coolant filter: A non-charged spin-on coolant filter shall be installed if required by engine manufacturer.

Air cleaner: Air cleaner shall be manufacturer's heaviest duty air cleaner that meets all the requirements of the extended engine warranty.

Fan: Thermostatically controlled, viscous type, or manufacturer's recommended automatic fan.

Screening system: Mounted in front of radiator grille that protects entire radiator from stones and bugs. Screening system to be approved by engine and truck manufacturer(s).

Engine vibration dampener.

Diesel Fuel Filter: There shall be a DAVCO 382 or a 482 filtration unit installed and mounted higher than fuel tank per manufactures recommendations in a location to accommodate filter replacements, yet be protected from road debris **(No substitute, standardization)**.

Mounting location to be determined at pre-build meeting.

Davco 382 Unit shall be equipped with engine coolant heat and 120 volt heater circuit. The 120 volt circuit and engine block heater shall be powered via the same electrical connection. **(No substitute, standardization)**

Davco 482 shall be equipped with a 12 volt and 120 volt heater circuit. 12 volt heater circuit will activate with the ignition key switch, the 120 volt heater circuit and engine block heater shall be powered via the same electrical connection. **(No substitute, standardization)**.

Air restriction gauge: Flush, dash-mounted with indicator slide for engine air cleaner, Re: FILTER MINDER, manufactured by Engineered Products Company, Tel: (319) 234-0231, or OEM installed electronic monitor.

Automatic idle shutdown shall be set to five (5) minutes. An audible warning alarm shall be provided to alert operator prior to engine shutting down.

ECM shall be set to a maximum of sixty five (65) miles per hour.

Governor: Set at manufacturer's recommended maximum engine speed (rpm).

Hoses: The air induction system and large radiator cooling system hoses shall be clamped with 0.500 inch wide, 150-inch LB stainless steel, constant torque, spring-loaded worm clamps. Ref: Wittek Manufacturing (Tel: (312) 492-9400) or Breeze Clamp Co, Constant Torque clamps with liner for silicone hoses. Cooling system hoses under 1 inch OD may use factory standard hose clamps, as a minimum acceptable standard.

Lubricating oil lines: If hoses are used they shall be wire braid type, "AEROQUIP" or approved equal system, minimum standard.

SPECIFICATIONS
A-48-DO-A-AL

I. GENERAL TRUCK SPECIFICATIONS: (Continued)

D. VEHICLE COMPONENTS: (Continued)

12. EXHAUST:

Vertical tailpipe with elbow and muffler system or horizontal muffler and vertical tail pipe with elbow. Exhaust system shall neither interfere with the van body nor will it be close to any fluid tank. The flex in the body when operating on an uneven terrain must be considered in the design. The muffler and tail pipe shall be shielded or insulated to protect personnel from burns when entering or exiting the cab. The shield shall be 180 to 360 degrees and shall be of non-rustable material such as stainless steel or aluminum. Riker or equal.

13. FAST LUBE OIL CHANGE SYSTEM (FLOCS):

This FLOCS system shall be installed with all fittings, brackets, clamps and hoses. Hose from oil pan to FLOCS fitting shall be hydraulic hose with a 100R2 rating and properly secured. The system shall be compatible with all fittings presently used by the Department. The final placement of the male half of the snap coupler, on the equipment, shall be determined at the pre-build meeting. Ref: EQN-351A.

14. FRAME:

The Resisting Bending Moment (RBM) shall be a minimum of 1,000,000 inch LB per rail, for the entire length of the frame, including any frame liners, except where engine and radiator adjustments are required. Frame material shall be of at least 110,000 PSI yield strength. (Drop frames are not acceptable).

Main frame and any required liners shall be either straight channel or offset channel, full length. Minimum frame RBM shall be approved by manufacturer's Engineering Department.

15. INSTRUMENTATION:

All instruments shall be dashboard-mounted unless specified otherwise.

All standard instruments shall be supplied including but not limited to the following:

Oil pressure gauge

Water temperature gauge

Transmission oil temperature gauge. (Automatic only)

Air pressure gauge(s) for dual circuit, dual indicator.

Fuel gauge

Hourmeter that records only when the engine is running, mounted for operator visibility.

Speedometer with odometer.

Tachometer

Voltmeter

SPECIFICATIONS
A-48-DO-A-AL

I. GENERAL TRUCK SPECIFICATIONS: (Continued)

D. VEHICLE COMPONENTS: (Continued)

16. PAINT:

Cab shall be painted PennDOT yellow Ref: DuPont F9885, PPG 85246, Sherwin Williams 73266, Sikkens 4017 or NAPA 73266 for shade only. Frame and all underside components shall be painted black. Front bumper and plow frame shall be primed and painted black (with hardener) low VOC. All bare metal surfaces shall be coated using etching primer prior to paint. All surfaces shall be properly cleaned and prepared prior to paint, with all weld splatter and debris removed. Cab and van body sides except front panel shall be painted PENNDOT yellow Bumper shall be painted black or argent.

17. SAFETY:

Grab handles shall be supplied on all cab entry locations. Anti-slip paint is required on all handholds, for the entire length, (tape is unacceptable). All handrails, ladders, and step configurations shall be built for three points of contact.

First aid kit mounted in the cab (Ref: AW Direct Part No. FA-10, Tel. 1-800-243-3194), or equal.

Fire extinguisher: Rechargeable with vehicle mount. Mounted in the cab for easy and quick access. Ref. 3A:40BC (5 LB).

Placards: There shall be changeable placards affixed to both sides of the vehicle and front and rear.

There shall be conspicuity tape applied per EQN-127A.

Wheel chocks and holder per EQN-82.

Triangle kit stowed in the cab per EQN-66A

There shall be a permanent decal, "Three Point Contact" located at each entry point of the truck cab and at each bed ladder area per EQN – 552-1. Exact location to be determined at pre build meeting.

18. STEERING:

Dual integral or single integral type hydraulic power steering.

Glidecoat steering shaft, Bendix wedge lock lube-for-life shaft or ZF type steering shaft.

Steering system (e.g. Flow, pressure, relief valve etc.) Shall be selected considering the full front-GAWR axle loading. Ref: ROSS, SHEPPARD or TRW gear assembly. (No substitute, standardization).

Hydraulic supply pump, vane type or roller type supply pump with sufficient oil flow to permit one (1) steering wheel revolution per second with front axle loaded to rated capacity, in a "park" condition.

Power Steering Reservoir, "remote mounted", incorporating a filter which is easy to remove and replace. The remote filter referenced above shall be factory mounted, certified and engineering approved in conjunction with the appropriate pump. The pump shall not be the integral filter type unit.

19. SUSPENSION: FRONT:

16,000 LB capacity, minimum.

Two (2) shock absorbers.

SPECIFICATIONS
A-48-DO-A-AL

I. GENERAL TRUCK SPECIFICATIONS: (Continued)

D. VEHICLE COMPONENTS: (Continued)

20. SUSPENSION: REAR:

Suspension shall be tailored to axle loads and shall be adequate to sustain maximum GVW without overload or permanent set.

11,500 LB capacity at ground each rear spring, minimum.

2,250 LB capacity, separate auxiliary spring, minimum.

21. TANK - FUEL:

Safety - Type fuel tank as per the requirements of FMVSS.

Minimum fuel capacity 80 gallons dual tanks are unacceptable. Tank must be aluminum or stainless steel, unpainted.

Heavy duty mounting straps with rubber shims/liners.

Heavy duty aluminum or stainless steel with minimum 2 in wide straps and gaskets.

Accessible fill pipe (located at either end of tank to avoid interference with steps).

Minimum of two (2) steps shall be mounted to the tank bands (stainless or aluminum with rubber liners) permitting easy access to cab, with optimum safety. The outer step edge must be banded and serrated in lieu of plain smooth metal edge, Ref I.D.5.

22. TIRES/WHEELS:

The truck shall be equipped with hub piloted steel disc wheels for tubeless tires. The wheel end shall be equipped with outboard cast brake drums, and 15 degree tubeless steel wheels, hub piloted, 10 hole - 285.75mm bolt circle with 22mm two-piece flange nuts.

Front: Wheels: 22.5 x 9.00, 10 hole - 285.75mm bolt circle with 220mm bore, tubeless steel disc wheel rated at 10,000 LBS at a maximum inflation pressure of 120 PSIG. Accuride part number 29039 or 50344PG. **(No substitute, standardization).**

Rear: Wheels: 22.5 x 8.25, 10 hole - 285.75mm bolt circle with 220mm bore, tubeless steel disc wheel rated at 7,500 LBS at a maximum inflation pressure of 120 PSIG. Accuride part number 28828 or 29169. **(No substitute, standardization).**

The dual rear wheel/tire assembly shall have clearance between the tires, which permits the use of dual tire chains.

Wheel-Guard Separators: The wheel ends shall be equipped with the Accuride part number 5903 Wheel Guard Separator as follows:

Front axle - between the wheel and the brake drum.

Rear axle - between the inner dual and the brake drum and between the inner and outer duals.

Paint: The wheels shall be topcoat painted with TGIC Polyester Powder Paint MLD-82008 High Gloss Gray or equal applied over Cathodic Electro-Disposition Gray Primer.

Tires: All tires shall be radials.

Front Tires: 315/80R22.5 (Load Range L).

Rear Tires: 12R22.5 (Load Range H).

SPECIFICATIONS
A-48-DO-A-AL

I. GENERAL TRUCK SPECIFICATIONS: (Continued)

D. VEHICLE COMPONENTS: (Continued)

TIRES/WHEELS: (Continued)

<u>MANUFACTURER</u>	<u>FRONT TIRE</u>	<u>REAR TIRE</u>
Goodyear	G-289	G-282 MSD / G-622 RSD
Michelin	XZY3	XDN-2
Bridgestone	M843 L320	

23. TRANSMISSION: See POWER TRAIN OVERVIEW for acceptable transmission.

AUTOMATIC:

Oil cooler for transmission required due to prolonged transmission torque converter operation in low gears. Cooler size must be provided to keep the transmission fluid at an acceptable operating temperature under these prolonged conditions. (Water-to-oil type cooler.) An Allison approved cooling system shall be installed regardless of whether retarder is incorporated in the system or not. Automatic transmission cooler lines shall be stainless steel or a **preapproved** no-rusting material.

Automatic transmission cooler lines shall be stainless steel or a preapproved no-rusting material.

NOTE: All vehicles shall have a transmission-operated safety starting switch.

SPECIFICATIONS
A-48-DO-A-AL

I. GENERAL TRUCK SPECIFICATIONS: (Continued)

E. VAN BODY:

The following van body shall be furnished and installed on the specified chassis.

1. BODY DIMENSIONS:

TRUCK, PONY, 20 FEET BODY, "Inside" length (actual cargo area) (062300);

TRUCK, PONY, 24 FEET BODY, "Inside" length (actual cargo area) (062700);

96 inch maximum outside width.

90 inch inside width.

12 feet 6 inch maximum body height, mounted.

Inside body height, from bottom of rolled up door to floor, must accommodate a forklift (89 inch height min.).

2. BODY MATERIAL:

All body skins, except front panel, shall be painted to match the cab.

There shall be box mounted wind deflector of adequate size to offer minimum wind resistance and maximum fuel mileage. Deflector shall be bolted in place. Temporary attachment is unacceptable. Ref. Nose-Cone Part# NC38-RM2.

2 long sills: 4 inch structural "I" beams 3.19 LB per foot, minimum, or 70,000 PSI minimum.

Cross members: 3 inch minimum, structural "I" beams 2.869 LB per foot, minimum, or 70,000 PSI minimum.

Cross members shall be located on 12 inch centers maximum.

Aluminum body skin shall be 0.040 inch minimum, riveted on 3 inch centers max.

Galvanized or Aluminum "Z" section with posts 1.250 inch deep at 0.048 LB per foot, minimum, shall be stationed on 16 inch centers or hat post 1.250 inch - 24 inch centers.

Four (4) - 0.6250 inch dia. minimum "U" bolts per long rail with self locking nuts, and they shall be backed by an additional nut (double nutted).

The "U" bolt mounting brackets and cross brackets shall be min. 0.3750 inch thick x 2 inch x 2 inch (angle) material.

There shall be one (1) hardwood strip placed between the "I" beam and the frame rail. There shall be no more than two (2) pieces on each rail. The "I" beam shall have steel filler plates or wooden filler blocks wherever "U" bolts are placed. All gussets, brackets, filler plates, in addition to all necessary welding shall be full welded. Tack or step welds are unacceptable. All cutting shall be ground smooth.

The entire front of the van body shall be polished or milled aluminum or stainless steel, unpainted.

The front top and front corner posts shall incorporate a radius to serve as a wind deflector.

The top corners shall incorporate a heavy casting or heavy fabricated extrusions the casting shall be designed to indent and protect the front top clearance lights. Wires shall be in conduit and sealed into the lights.

Sides and bulkhead shall be lined using 0.3750 in ACX type or C backer (with full finish face) plywood, good 1 side attached with rivets or screws on 8 inch centers.

The sides and front bulkhead shall be lined with 0.0781 inch thick min. (14 gauge) 16 inch high kick plate.

SPECIFICATIONS
A-48-DO-A-AL

I. GENERAL TRUCK SPECIFICATIONS: (Continued)

E. VAN BODY: (Continued)

2. BODY MATERIAL: (Continued)

Side walls shall be furnished with two (2) per side full length flush mounted cargo restraining tracks located at 18 inch and 44 inch centered heights from the floor, ref. KINEDYNE Series E track, NOTE: Supplied on Pony truck only.

Two (2) 20 feet long x 2 inch wide load binding straps and ratchet(s) compatible with the restraining tracks shall be furnished.

There shall be a minimum of six recessed tie downs located in the floor. These tie-downs shall be connected to framing or cross members. Connection to floor only is unacceptable.

3. REAR DOOR:

Fully sealed door (top, bottom and sides).

Full width overhead roll up type with lockable cast hardware package.

0.7500 inch thick solid door covered with aluminum and painted to match side panels.

Heaviest available track and hinges.

Ref. WHITING, with quick change rollers - or equal

Remote Control: There shall be a remote control (portable) for the rear door. There shall also be a cab mounted switch for deactivating the remote control.

4. SIDE DOOR - CURB SIDE AND STREET SIDE:

One (1) single panel side door using a door frame shall be provided approximately 48 inch back from front bulkhead on curb side and street side. 40 inch wide x 76.500 inch high.

Door shall have heavy duty hardware and lockable latch.

A hold open device shall be provided.

Water tight seals required.

Grab handles shall be supplied on all cab entry locations. Three points of contact shall be achievable at all cab entry locations and they shall be coated with non-skid paint. See "Safety" page 12 (**tape is unacceptable**).

Side entry steps (both sides). Ref. EQN-229, attached, or other approved system, with platform.

***Note** Curb side, street side doors and platform shall be installed to provide access and egress to the rear of the body.

Design drawing of steps and platform shall be submitted and approved prior to production of body.

5. ELECTRICAL:

Two (2) 8 in inside dome lights mounted at 1/3 and 2/3 of body length (relocation acceptable if they interfere with rear door) with a dash mounted switch with indicator light in cab. Reference 80355 TRUCK-LITE or equal.

Clearance lights shall be provided to meet all PA State Inspection Laws.

6. FLOOR

1.3750 inch thick minimum laminated hardwood.

Each board shall be bolted or screwed to the cross members, 2 screws per board per cross member.

The boards shall be full length of bed, 1 piece, no splices.

SPECIFICATIONS
A-48-DO-A-AL

I. GENERAL TRUCK SPECIFICATIONS: (Continued)

E. VAN BODY: (Continued)

7. ACCESSORIES:

Front mounted steel mud flaps.

Rear mounted rubber mud flaps, per EQN-66.

There shall be an underbody tool box, lockable, Ref: Weather Guard Part No. 536 (or larger),
Tel. 1-800-456-7865.

8. LIFT GATE:

A hydraulic/electric tailgate assembly with side bumpers. Galvanized finish on lift frame and level lift platform Ref. WALTCO or ANTHONY Flip-away or equal model meeting specifications.

84 inch x 48 inch

Metal or vinyl splash guard to protect switches, motors and pump.

Heavy duty switch.

Platform and hydraulic component located under body.

3,000 LB capacity minimum.

There shall be a fixed step recessed shock mounted lights, and heavy-duty dual dock bumpers on both sides per EQN-270.

8a. **OPTION: Heavy Duty Trailer Tow Package shall be integrated with the lift gate.**

Heavy Duty Trailer Tow Package: minimum 16,000 pounds capacity.

A pintle hitch shall be installed on a minimum 2 inch X 6 inch heavy walled steel box properly supported to frame and cross member, with minimum 3/8" steel gussets added between frame rails and box. Pintle hitch shall be installed approximately 28 inch from ground level to center of pintle eye.

There shall be two (2) D-ring safety chain hooks, mounted one to each side of the pintle hitch.

Provision shall be provided for a trailer break away cable clip for a surge brake equipped trailer in close proximity to the pintle hitch.

(1) One 7-way female (pin type) electrical trailer plug connection, installed Ref. EQN-80A.

9. ROOF:

Roof shall be translucent glass-board (fiberglass reinforced polyester, minimum 0.060 inch thickness).

Panels shall be manufactured by a continuous laminating process with a pebble-like embossed finish on the exterior side (light transmission 45% minimum). The glass-board shall have extra fiberglass built-in to the edges, for additional strength. The glass-board roof shall be supported completely around the perimeter and every 24 inch. The perimeter edges shall have an over-lay channel and shall be sealed with weatherproofing tape. Ref. KEMLITE Glass-board.

SPECIFICATIONS
A-48-DO-A-AL

II. DRAWINGS:

EQN-66	Dated	Rev.	07-20-09	2 sheets	SPLASH GUARDS
EQN-66A	Dated	Rev.	07-20-09	1 sheet	TRIANGLE STORAGE BOX
EQN-78	Dated	Rev.	10-27-06	1 sheet	CB RADIO CONNECTIONS
EQN-80A	Dated	Rev.	08-02-16	1 sheet	7 WAY TRAILER CONNECTOR
EQN-82D	Dated	Rev.	07-22-15	1 sheet	CHOCK & HOLDER
EQN-120T	Dated	Rev.	07-31-12	1 sheet	PONY TRUCK LIGHTING
EQN-127A	Dated	Rev.	01-02-09	1 sheet	CONSPICUITY
EQN-229	Dated	Rev.	06-11-14	2 sheets	SIDE ENTRY STEP
EQN-270	Dated	Rev.	06-16-14	1 sheet	TRUCK FIXED STEP
EQN-351A	Dated	Rev.	06-19-13	2 sheets	FAST LUBE OIL CHANGE SYSTEM
EQN-501	Dated	Rev.	06-08-09	2 sheets	CENTRALIZED LUBE SYSTEM
EQN-552	Dated	Rev.	05-29-13	1 sheet	MAX. TRAVEL HEIGHT
EQN-552-1	Dated	Rev.	03-23-15	1 sheet	THREE POINTS OF CONTACT

The above referenced drawings shall become part of these specifications.

These drawings reflect the intent of the Department and any discrepancies shall be resolved at the line setting ticket meeting between the vendor and the Equipment Chief, or the pre-production inspection of the truck.

DRAWINGS APPEAR AT THE END OF THE SPECIFICATIONS.

SPECIFICATIONS
A-48-DO-A-AL

III. MANUALS:

The successful vendor shall furnish all applicable manuals per unit:

- 1 Operator's
- 1 Parts
- 1 Service
- 1 Engine
- 1 Transmission (Automatic or Manual)
- 1 Body and Sub-frame (Parts and Service)
- 1 Complete set of manuals for any additional items/equipment added to a piece of equipment.

The manuals listed shall be official O.E.M. publications supplemented with technical manuals for all components as published by sub-vendors/manufacturers.

Parts Manual presented must be a relative to "all" items utilized to build these units, with appropriate part numbers.

Delivery of these manuals shall be completed within a maximum of 90 days after the pilot model is accepted.

Manuals may be supplied on CD Disc in lieu of paper manuals.

SPECIFICATIONS
A-48-DO-A-AL

IV. TRAINING:

Mechanic:

The successful vendor shall provide services of qualified factory trained technicians for not more than 0 training sessions of not more than 0 hours at 0 PennDOT locations to train personnel for in-depth preventive maintenance, overhaul and review of the proper usage of parts and service manuals, as well as component/system adjustments that need to be monitored at specified service intervals.

Operator:

The successful vendor shall provide services of qualified factory trained technicians for not more than 0 training sessions of not more than 0 hours at 0 PennDOT locations to train personnel in the proper operation, safety and servicing of the equipment.

The successful vendor shall submit a training plan to the Fleet Management Division for approval within 45 days after receipt of the Purchase Order. The training plan shall consist of course outline and class schedule.

All training must be completed within 60 days after the dates established in the approved training plan unless an extension is mutually agreed to in writing by the Chief of the Fleet Management Division.

All training shall be coordinated with the District Equipment Managers, with the exception of Asphalt related training, which must be coordinated with the Statewide Training Coordinator (717) 787-4836, Fax (717) 783-4438.

SPECIFICATIONS
A-48-DO-A-AL

IV. WARRANTY: Per PCID No. 1075.

ENGINE WARRANTY:

The successful vendor and or supplying OEM shall provide the Department with a 100% parts and labor engine warranty FOR 60 months / 150,000 miles / 5,400 hours minimum. In addition to the engine warranty, the engine block shall be warranted against external perforation from corrosion for 60 months, 100% parts and labor.

NOTE: The oil pan shall be warranted against corrosion, rust, rust thru etc. regardless of atmospheric conditions for 60 months, 100% parts and labor.

EMISSION WARRANTY: The successful vendor and or supplying OEM shall provide the Department with a 100% parts and labor warranty for all emission related components to include the diesel particulate filter (DPF) FOR 60 months / 150,000 miles / 5,400 hours minimum. Shall be warranted against corrosion, rust, rust thru etc. regardless of atmospheric conditions.

RADIATOR WARRANTY:

Manufacturer service and warranty policy for radiator shall be for two (2) years, 100% parts and labor plus an additional three (3) years, 100% parts only.

TRANSMISSION WARRANTY:

Manufacturer service and warranty policy for automatic and manual transmissions shall be 60 months 100% parts and labor.

BODY ELECTRICAL/LIGHTING:

Wiring harness shall be 5 years 100% parts. First year shall include 100% labor.

All LED lights shall be 5 years 100% parts.

NOTE: WARRANTY REPAIRS SHALL BE COMPLETED AT THE MANUFACTURER'S LOCATION OR IN-HOUSE FIELD REPAIR COMPLETED BY PENNDOT. IT SHALL BE THE DEPARTMENTS DISCRETION TO REPAIR INTERNALLY OR TRANSPORT THE UNIT TO THE DEALERSHIP. THE MANUFACTURER SHALL REIMBURSE THE DEPARTMENT AT THE MANUFACTURERS STANDARD PUBLISHED IN-HOUSE LABOR RATE. THE LABOR RATE SHALL BE MUTUALLY AGREED UPON BETWEEN THE DEPARTMENT AND VENDOR/BIDDER. ALL IN-HOUSE WARRANTY DOCUMENTATION SHALL BE DELIVERED WITH THE PILOT MODEL. ALL WARRANTY DOCUMENTATION SHALL BE DELIVERED WITH THE PILOT MODEL.

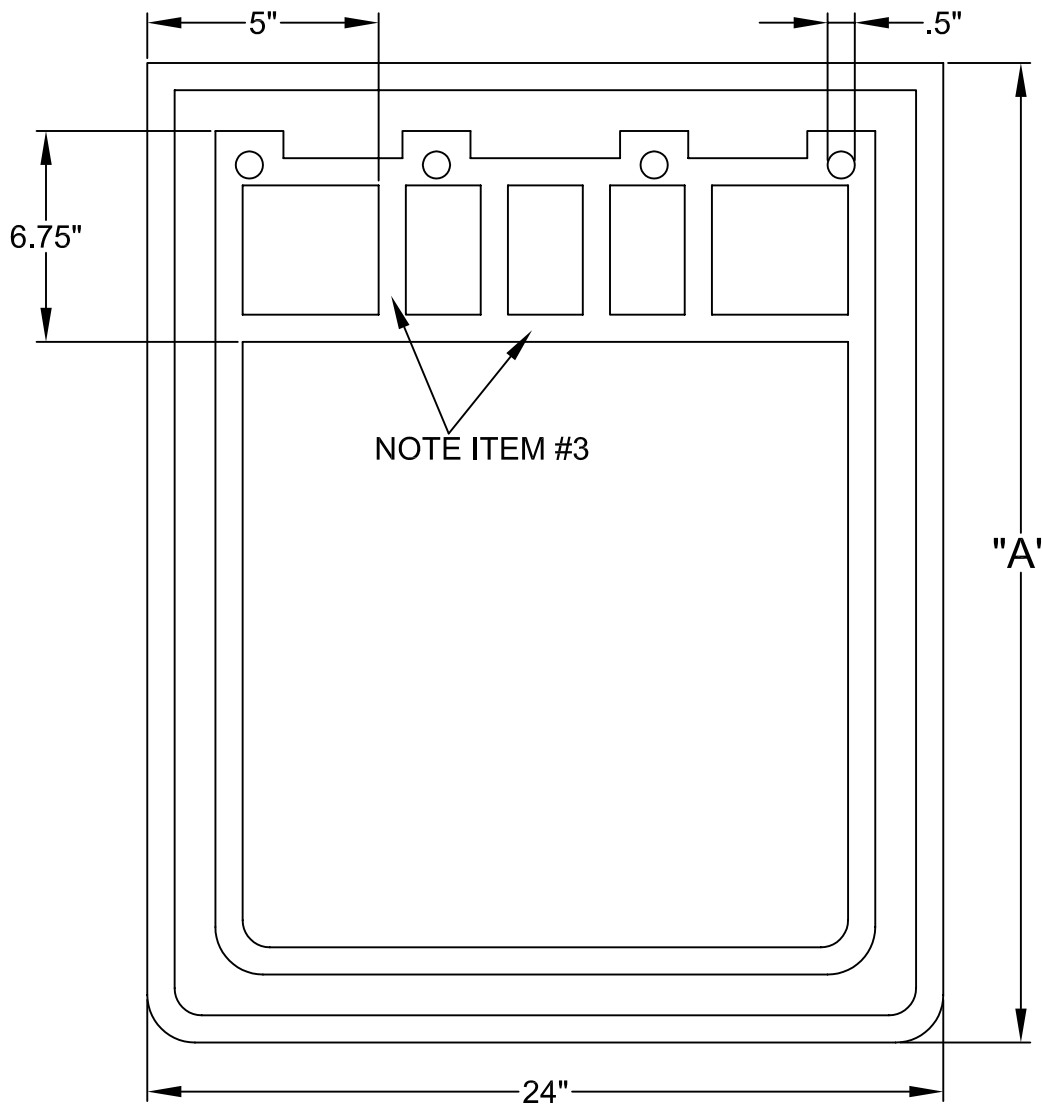

SAFETY

PA DEPARTMENT OF TRANSPORTATION

REVISIONS			SPLASH GUARDS-RUBBER TRAILER & TRUCK		
NO.	DATE	BY	DRAWN BY	SCALE	
1	05-28-02	DWG			
2	11-28-06	CJW	S.T.	N/A	EQN-66
3	07-20-09	TOD	DATE 11-18-87	CHK'D BY RED	SHEET 1 OF 2

FENDERS AND FLAPS: VEHICLES SPECIFIED UNDER THIS SUBCHAPTER SHALL BE EQUIPPED WITH FENDERS WHICH PROVIDE AT LEAST AS MUCH COVERAGE OF THE WHEEL AS THE ORIGINAL EQUIPMENT. ALL WHEELS SHALL BE SUFFICIENTLY COVERED WITH FENDERS OR FLAPS SO AS TO PREVENT LOOSE OBJECTS, RAIN, SNOW, AND THE LIKE FROM BEING THROWN ABOUT IN A MANNER WHICH MAY INTERFERE WITH OTHER PERSONS USING THE HIGHWAY.

REAR WHEEL SHIELDS: VEHICLE SPECIFIED UNDER THIS SUBCHAPTER EXCEPT TRUCK-TRACTOR WHILE TOWING A TRAILER SHALL BE CONSTRUCTED OR EQUIPPED AS FAR AS TO BAR WATER OR OTHER ROAD SURFACES THROWN FROM REAR WHEELS OF SUCH VEHICLE OR COMBINATION AT TANGENTS ESCEEDING 22.5 DEGREES, MEASURED FROM ROAD SURFACE FROM PASSING IN STRAIGHT LINE TO THE REAR OF SUCH VEHICLE. SEE 75 PA C554533 (RELATING TO REAR WHEEL SHIELDS)

AREA 6.75"x24" ACROSS THE TOP IS ACCEPTABLE IN SOLID VIS RIBS PROVIDED IT MEASURES .225" IN THICKNESS

THE BODY OF SPLASH GUARD SHALL BE A MINIMUM OF .09375" THE TRIM AREA SHALL BE $\frac{3}{8}$ " MINIMUM THICKNESS. THE BODY AREA IS THE AREA WITHIN THE OUTSIDE DIMENSIONS OF 24"x36" TOLERANCES +/- .250" THE WEIGHT OF THE SPLASH GUARD SHALL BE 6LBS FOR 24"x30" AND 7.5lbs x 24" x 36" MINIMUM.

NOTE:

1. MATERIAL: MOLDED NATURAL OR SYNTHETIC BLACK TIRE CHORD IMPREGNATED RUBBER. OIL AND SALT RESISTANT.
2. ANTI-SAIL NOT ACCEPTABLE.
3. MANUFACTURERS STANDARD SIZE ACCEPTABLE IF ALL MINIMUM THICKNESS, DIMENSIONS, AND WEIGHT SPECIFICATIONS ARE MET.
4. AS PER PA VEHICLES EQUIPMENT AND INSPECTION REGULATIONS, SECTION 175-108.
5. DIMENSION "A" WILL BE 30" OF 36" AS NECESSARY, WHEN INSTALLED TO MEET PA MOTOR VEHICLE CODE OR AS SPECIFIED ON THE CONTRACT.

PA DEPARTMENT OF TRANSPORTATION						
REVISIONS			SPLASH GUARDS-RUBBER TRAILER & TRUCK			
NO.	DATE	BY	DRAWN BY	SCALE		
1	05-28-02	DWG				
2	11-28-06	CJW	S.T.	N/A	EQN-66	
3	07-20-09	TOD	DATE 11-18-87	CHK'D BY RED	SHEET 2 OF 2	

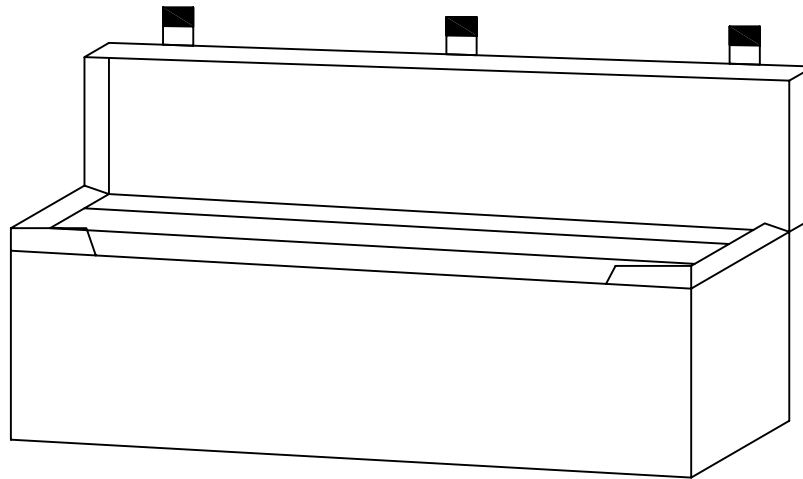

JAMES KING & CO.
 1-800-824-8635
 TRIANGLE PART #1005
 OR APPROVED EQUAL

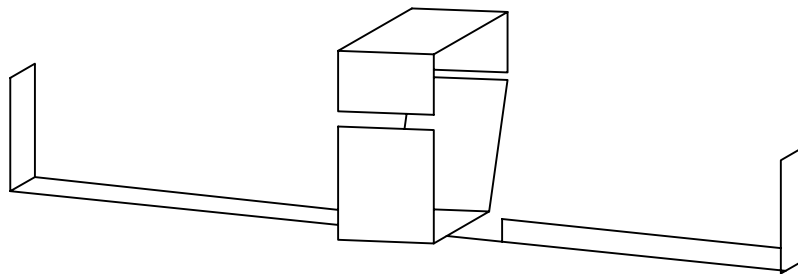

JAMES KING & CO.
 1-800-824-8635
 STEEL BRACKET PART #1005-B1
 OR APPROVED EQUAL

BOLTS, NUTS AND FENDER WASHERS SHALL BE
 USED TO SECURE METAL BRACKET.

PA DEPARTMENT OF TRANSPORTATION						
REVISIONS			TRIANGLE STORAGE BOX AND BRACKET			
NO.	DATE	BY	DRAWN BY	SCALE		
1	11-28-06	CJW				
2	05-31-07	KNH	WHM	N/A	EQN-66A	
3	07-20-09	TOD	DATE 04-23-92	CHK'D BY RED	SHEET 1 OF 1	

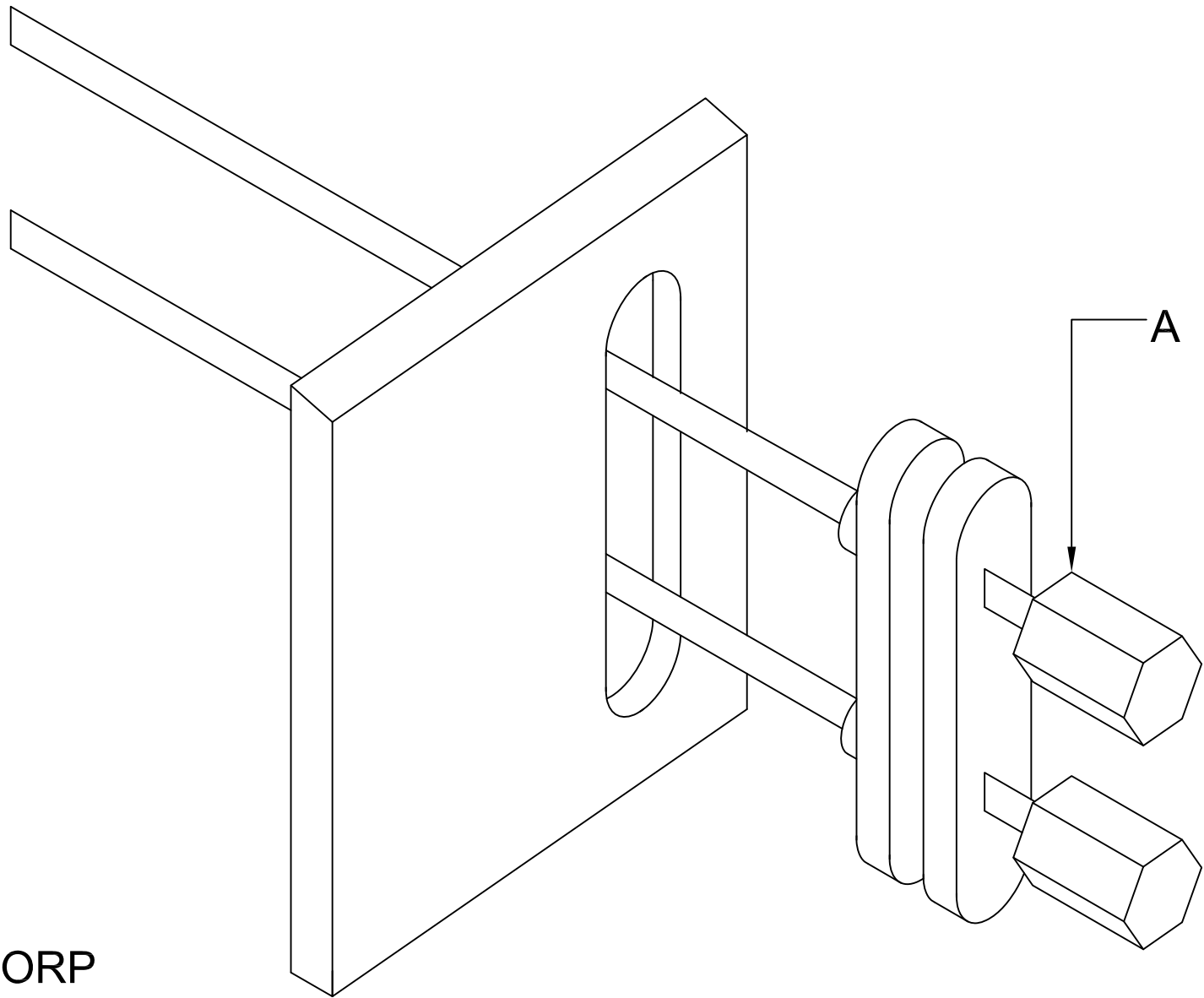

A.
 PANA PACIFIC CORP
 541 DIVISION STREET
 CAMPBELL, CALIFORNIA 95008
 408-374-7900

PART #531 277 C1

PA DEPARTMENT OF TRANSPORTATION					
REVISIONS			C.B. RADIO CONNECTIONS		
NO.	DATE	BY	DRAWN BY	SCALE	
1	08-15-90	WHM		N/A	EQN-78
2	07-02-97	DLW	WHM		
3	10-27-06	CJW	DATE 08-15-90	CHK'D BY RED	SHEET 1 OF 1

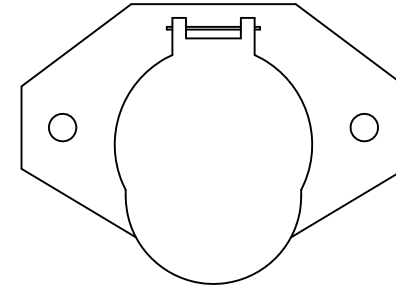
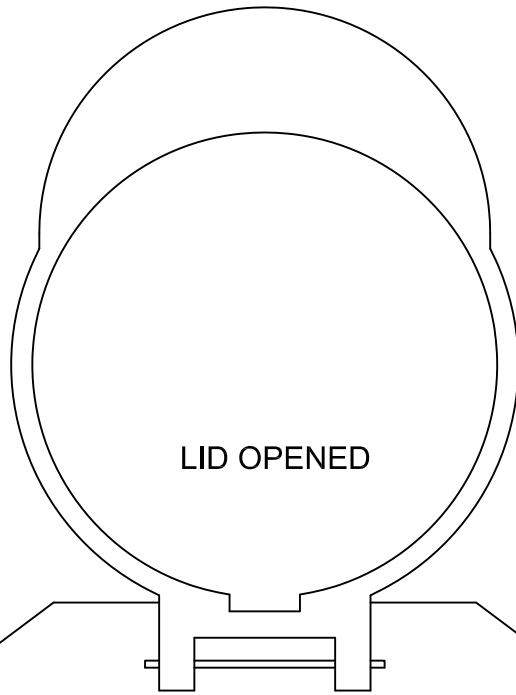

LID CLOSED

NOTES:

- VIEW OF FEMALE CONNECTOR, STANDING AT REAR OF TRUCK, LOOKING AT THE CONNECTOR.
- BRAKE LIGHTS SHALL FUNCTION WITH TURN SIGNALS.
- WIRE SHALL BE 7 WAY (1-10 GAUGE; 6-12 GAUGE) PER ATA COLOR CODE, CLAMPED EVERY 18" MINIMUM.
- CONNECTION SHALL BE MADE USING FACTORY OEM TRAILER WIRING HARNESS.
- ALL CONNECTIONS SHALL BE WATER TIGHT.
- ALL PINS SHALL BE ROUND STYLE.

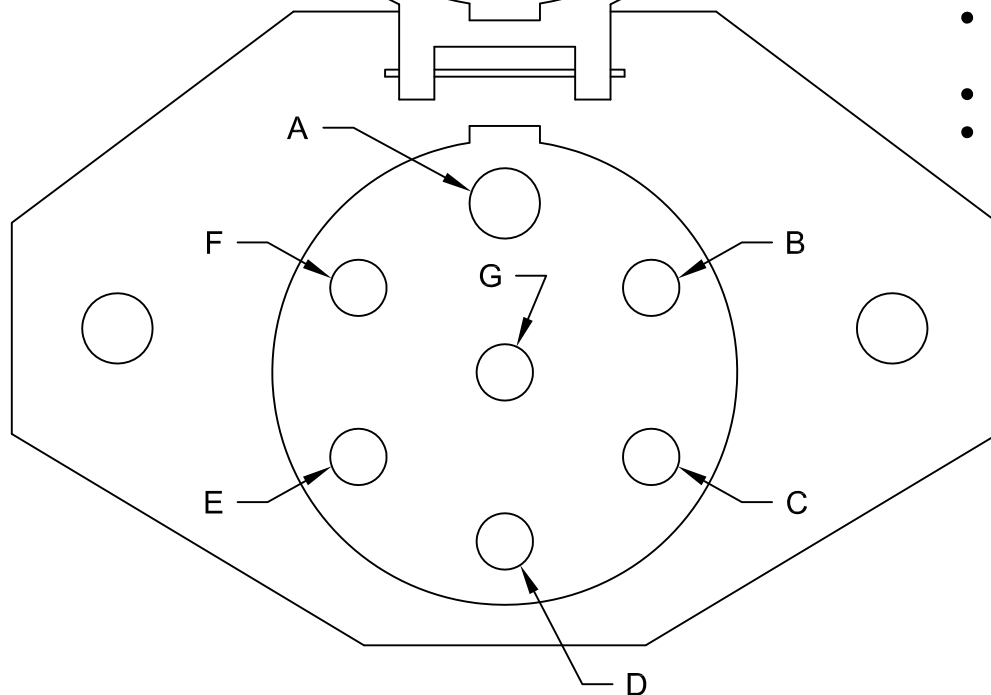

WIRING NOTES:

- A. WHITE: GROUND - 10
- B. BLACK: MARKER -12
- C. YELLOW: LEFT TURN & BRAKE - 12
- D. RED: STOP / BRAKE -12
- E. GREEN: RIGHT TURN & BRAKE - 12
- F. BROWN: TAIL - 12
- G. BLUE: ABS -12

PA DEPARTMENT OF TRANSPORTATION

REVISIONS			WIRING DIAGRAM / 7 WAY ROUND PIN FEMALE CONNECTOR		
NO.	DATE	BY	DRAWN BY	SCALE	
1					
2			JJB	N/A	EQN-80A
3			08-02-16		SHEET 1 OF 1

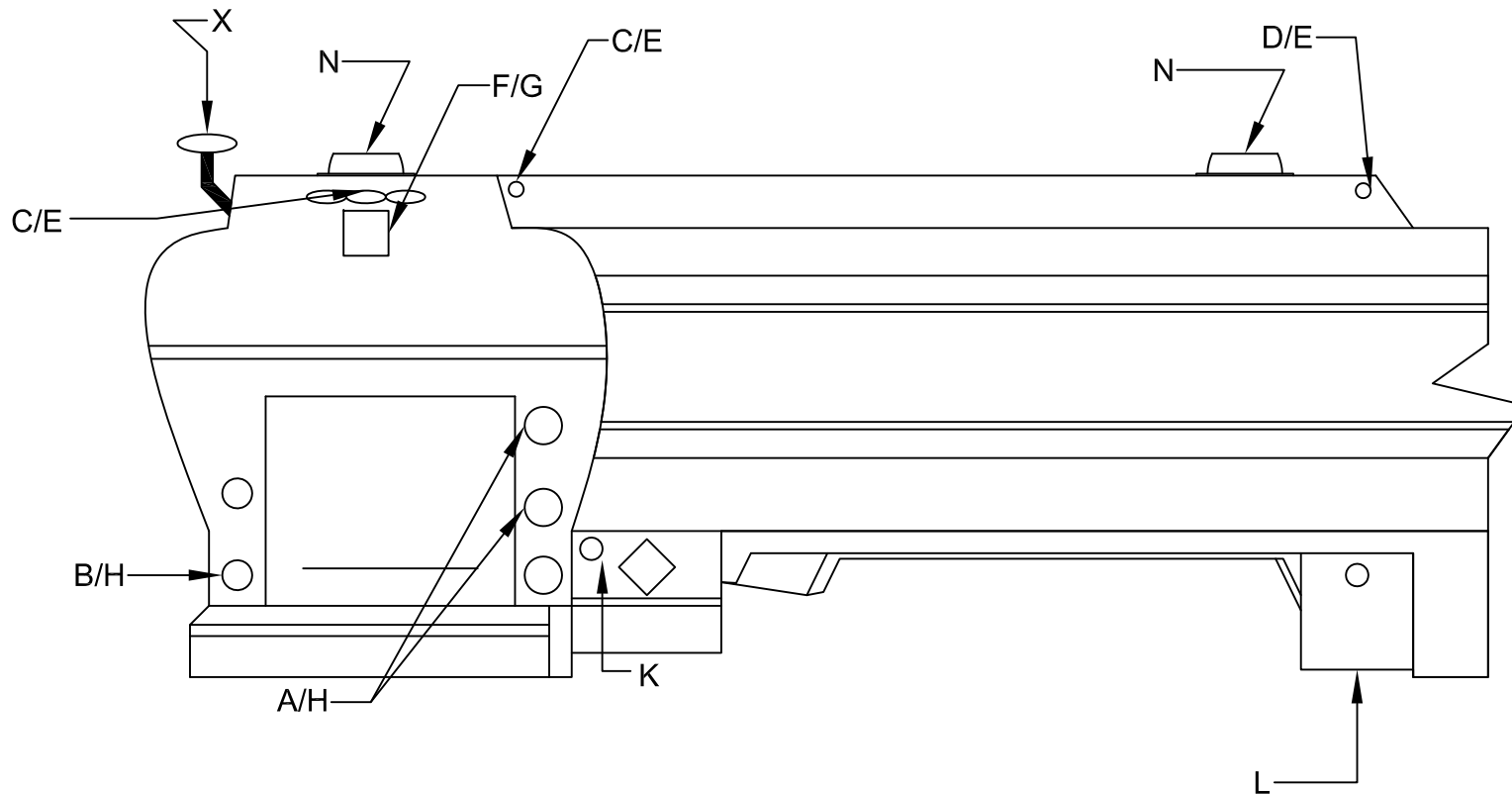

NOTE:

LIGHTING AND WIRING LOCATIONS ARE APPROXIMATE. APPLY A SMALL AMOUNT OF DI-ELECTRIC COMPOUND TO ALL TERMINAL AREAS UPON COMPLETION OF FINAL INSPECTION.

ALL EXTERNAL CABLES MUST BE SECURED EVERY 12in.-15in. ALL CABLE DIMENSIONS ARE SUBJECT TO VARIATION DUE TO CABLE ROUTING. IN NO CASE WILL SPLICES BE ACCEPTABLE EXCEPT IN A WEATHERPROOF JUNCTION BOX.

GROUNDING TO BE ACCOMPLISHED BY USING A GROUND WIRE THROUGHOUT. GROUND TO THE BODY IS UNACCEPTABLE.

ANY AND ALL "BODY THROUGH" HOLES SHALL HAVE GROMMETS.

THE MAIN POWER CABLE (7 WIRE) SHALL CONSIST OF AT A MINIMUM 8 GAUGE GROUND WIRE.

PA DEPARTMENT OF TRANSPORTATION					
REVISIONS			WIRING AND LIGHTING FUEL TRUCK		
NO.	DATE	BY	DRAWN BY	SCALE	
1	03-05-07	CJW			
2	05-15-07	KNH	WHM	N/A	EQN-80XF
3	08-07-12	MJW	DATE 10-23-92	CHK'D BY RR	SHEET 1 OF 3

NOUN		PART NO.		QTY.
A.	STOP, TAIL, TURN	GROTE	53102	4
B.	BACK-UP	GROTE	62211	2
C.	CLEARANCE MARKER, RED	GROTE	46742	2
D.	CLEARANCE MARKER, AMBER	GROTE	46743	2
E.	BRACKET FOR MARKER LAMP (BASE) W/PIGTAIL	GROTE	01-4399-70	7
F.	LICENSE LAMP	GROTE	60291	1
G.	BRACKET FOR LICENSE LAMP W/PIGTAIL	GROTE	01-4339-70	1
H.	GROMMETS FOR 4 IN STT & BW LAMPS	GROTE	91740	6
I.	WIRING HARNESS	GROTE	ULTRA BLUE MALE PIN HARNESS SYSTEM	
J.	CABINET LAMP	BETTS	B57JD	2
K.	REFLECTORS	PETERSON	B489R	2
L.	REFLECTORS	PETERSON	489A	2
M.	CABINET LAMP	BETTS	B47JD	2
N.	R10 - MINI BAR WARNING LIGHT	WHELEN	R10PADOT	2
X.	SAFETY MIRROR		K-10	1

PA DEPARTMENT OF TRANSPORTATION

REVISIONS			WIRING AND LIGHTING FUEL TRUCK		
NO.	DATE	BY			
1	12-16-96	WHM			
2	02-20-01	JLB	<small>DRAWN BY</small> WHM	<small>SCALE</small> N/A	EQN-80XF
3	03-05-07	CJW	<small>DATE</small> 10-23-92	<small>CHK'D BY</small> RR	SHEET 2 OF 3
4	08-07-12	MJW			
5					

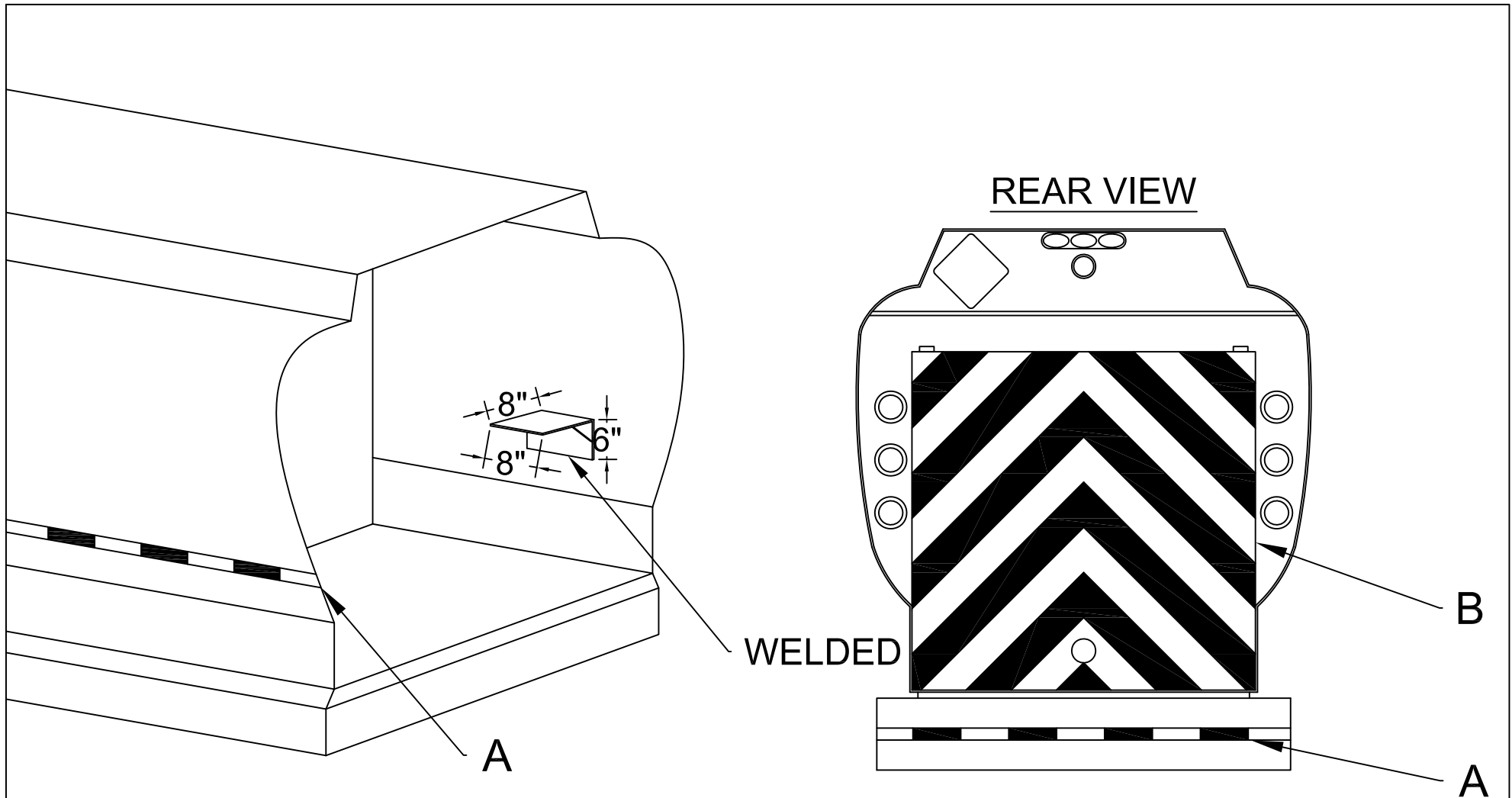

A) Reflectorized 2" wide marking shall be applied. Material shall be red/silver continuous backing Reflexite Conspicuity II System or 3M Scotchlite Conspicuity Sheeting Series 980.

B) Tape shall be Reflexite Daybright V92 conspicuity sheeting. Red - SRHI4R, Yellow - SRHI4Y. Two 4" sheets can be combined to equal the 8" requirement.

PA DEPARTMENT OF TRANSPORTATION				
REVISIONS			WIRING AND LIGHTING FUEL TRUCK	
NO.	DATE	BY	DRAWN BY	SCALE
1			MJW	N/A
2			DATE	08-07-12
3			CHK'D BY	
4				
5				

EQN-80XF
SHEET 3 OF 3

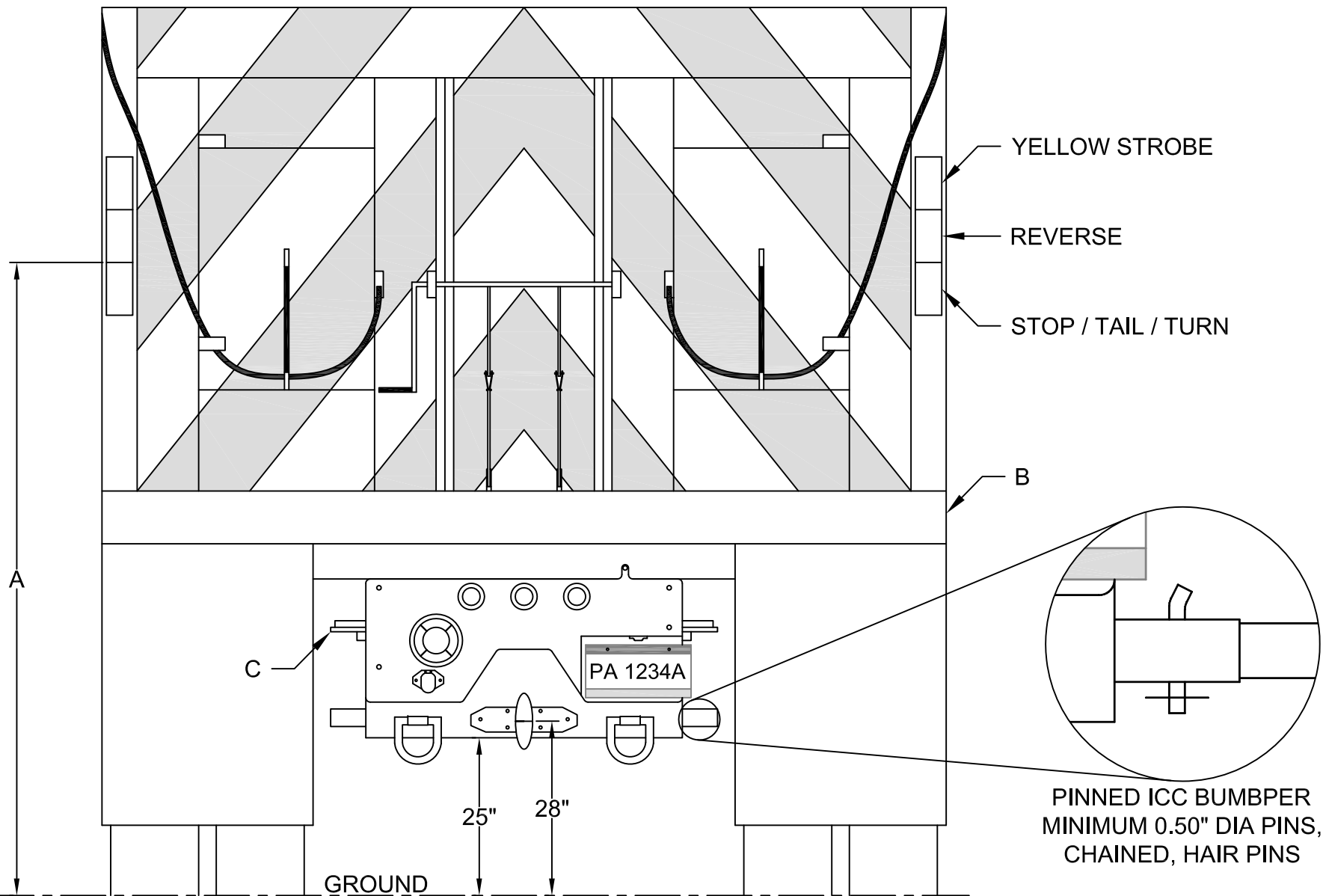

NOTES:

- A. HEIGHT OF LIGHTS SHLL NOT EXCEED 72". MEASURED FROM GROUND LEVEL TO TOP OF STOP / TAIL / TURN LIGHT WHEN IS BODY UNLOADED.
- B. SHALL BE ONE PIECE DESIGN, $\frac{3}{8}$ " X 6" MINIMUM 60661-T6 ALUMINUM. IT SHALL BE COMPLETELY WELDED.
- C. AIR BRAKE OPTION.

PA DEPARTMENT OF TRANSPORTATION

REVISIONS			REAR MODULE WITH RECESSED LICENSE PLATE		
NO.	DATE	BY	DRAWN BY	SCALE	
1			JJB	N/A	EQN-81X
2			DATE	08-02-16	CHK'D BY
3					SHEET 1 OF 2

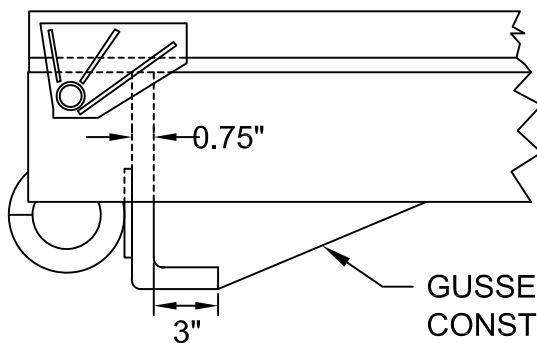
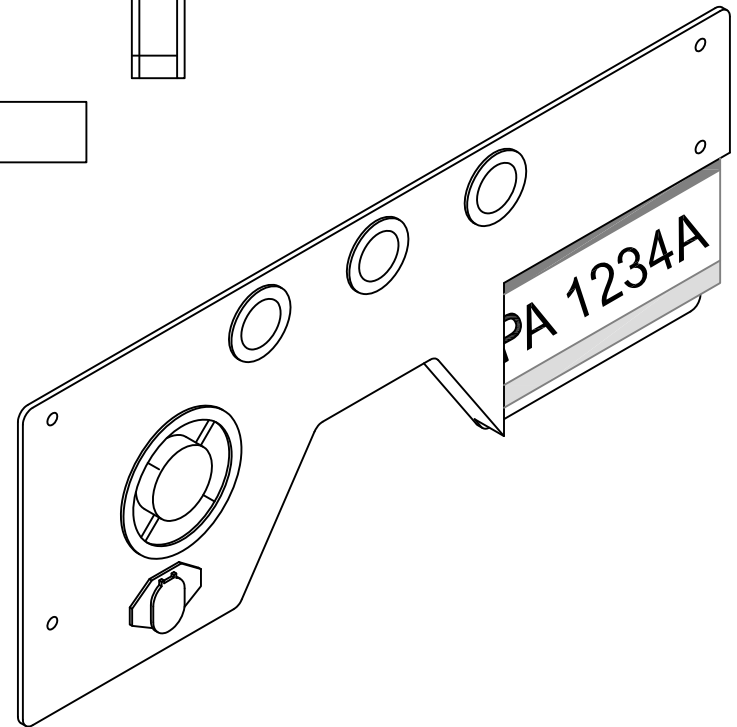
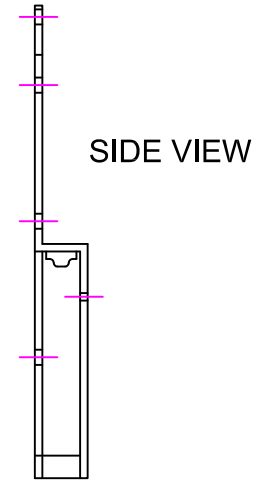
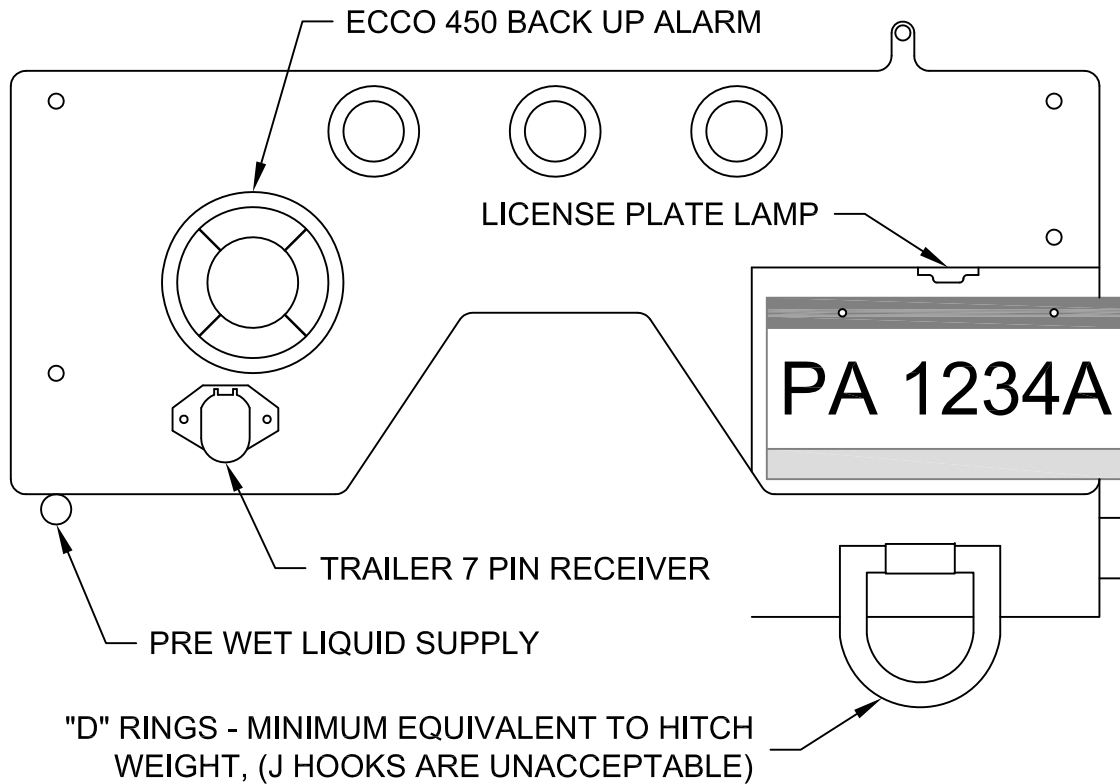

GUSSETS AND SUPPORTS SHALL BE CONSTRUCTED TO MEET 25 TON PINTLE REQUIREMENTS.

DUMP TRUCK REAR MODULE

THIS DRAWING IS NOT INTENDED TO SHOW ACTUAL BODY HINGE PIN PLACEMENT. CORRECT BODY HINGE PIN PLACEMENT TO MEET THE VEHICLES INTENT STATEMENT IS THE VENDORS RESPONSIBILITY.

PA DEPARTMENT OF TRANSPORTATION

REVISIONS			REAR MODULE WITH RECESSED LICENSE PLATE		
NO.	DATE	BY	DRAWN BY	SCALE	
1			JJB	N/A	EQN-81X
2			DATE 08-02-16	CHK'D BY	SHEET 2 OF 2
3					

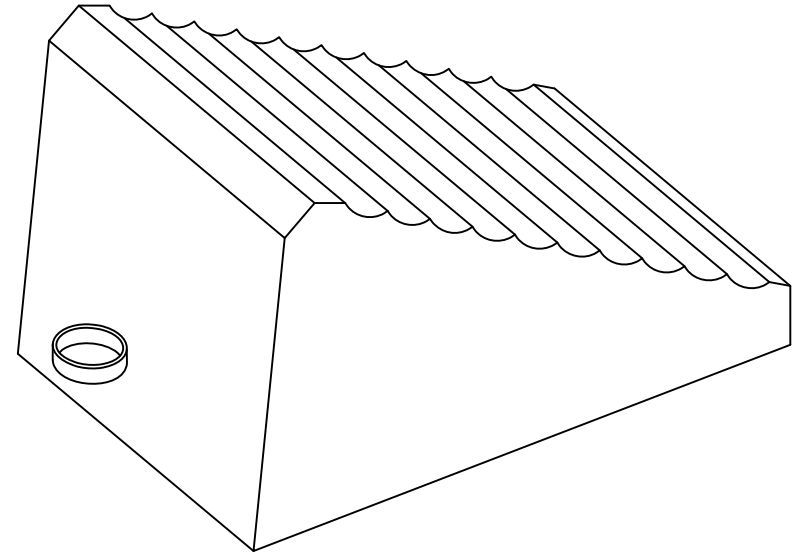
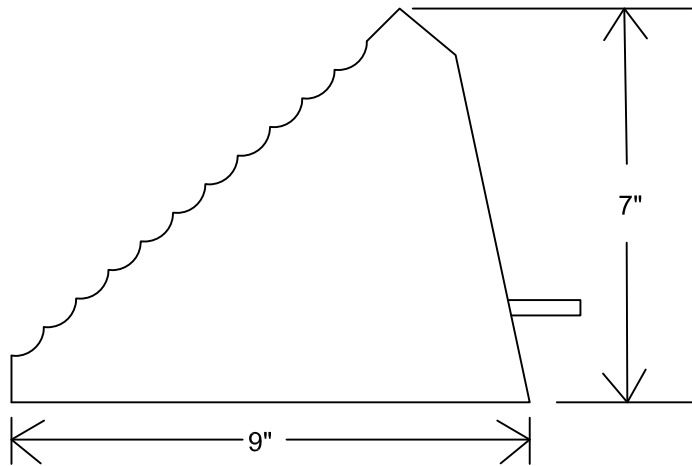

FINAL MOUNTING LOCATION SHALL BE DETERMINED AT THE PRE-BUILD MEETING. CHOCK HOLDERS SHALL BE ALUMINUM. TWO CHOCKS PER TRUCK SHALL BE SUPPLIED. CHOCKS SHALL HAVE 4 FEET OF $\frac{3}{8}$ INCH NYLON ROPE CONNECTING THE TWO CHOCKS TOGETHER.

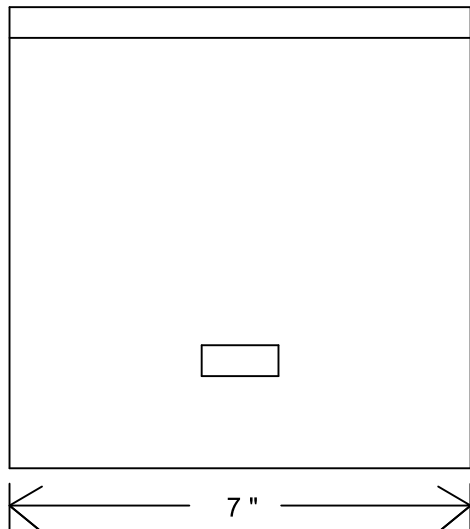

PA DEPARTMENT OF TRANSPORTATION					
REVISIONS			7" X 9" X 7" CHOCK AND HOLDER		
NO.	DATE	BY			
1					
2			<small>DRAWN BY</small> JJB	<small>SCALE</small> N/A	EQN-82D
3			<small>DATE</small> 07-22-15	<small>CHKD BY</small>	SHEET 1 OF 1

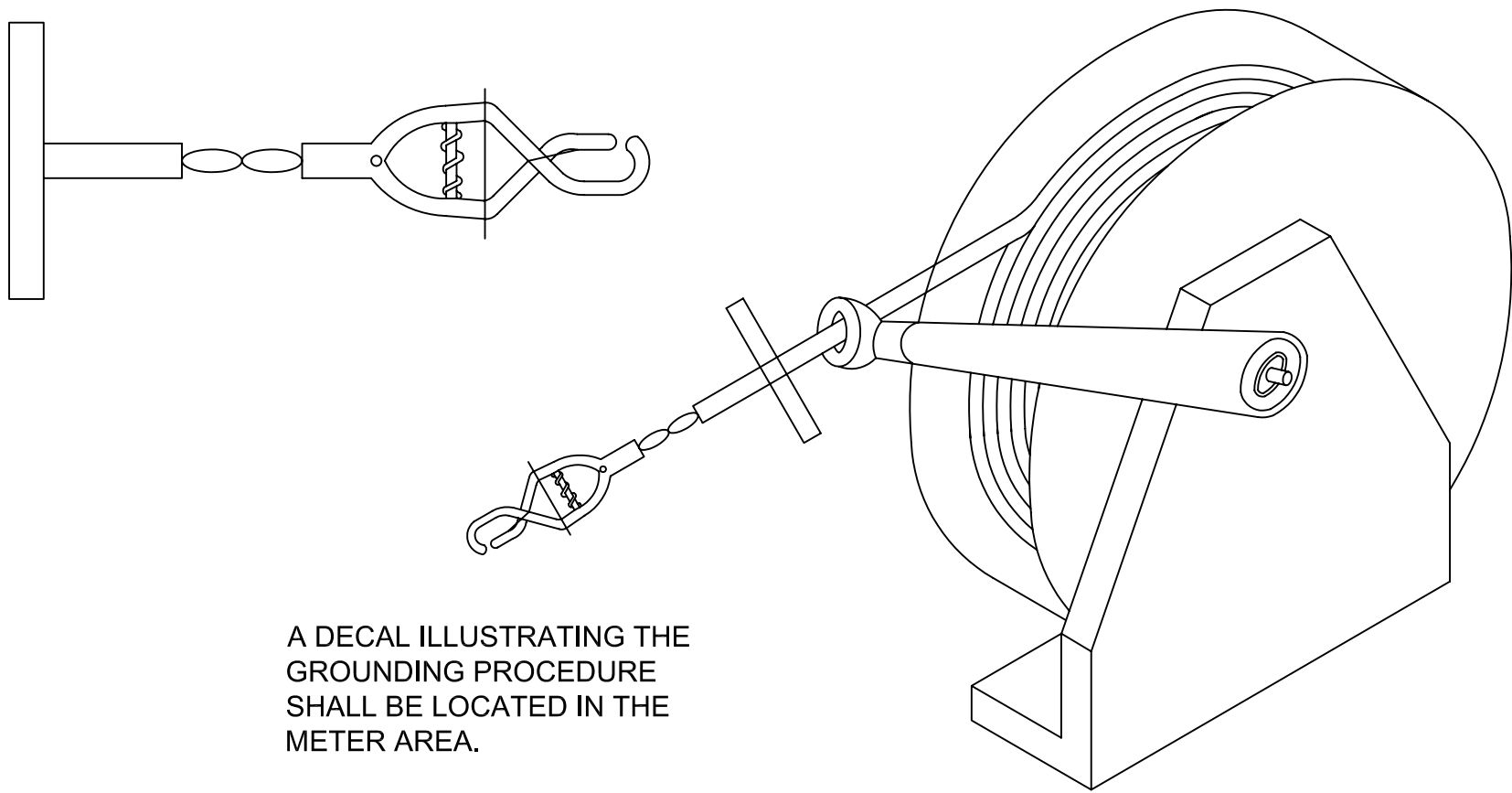

A DECAL ILLUSTRATING THE
GROUNDING PROCEDURE
SHALL BE LOCATED IN THE
METER AREA.

HGR 100 GROUND REEL #1 - UNREEL AND CONNECT TO ANY AVAILABLE GROUND POST

HGR 100-75-25 GROUND REEL (STATIC NEUTRALIZER) #2 - UNREEL AND CONNECT ONE
CABLE TO UNIT BEING FUELED AND THE SECOND LEAD TO YOUR FUEL TRUCK.

HANNAY REELS
553 STATE ROUTE 143
P.O. BOX 159
WESTERLO, NY 12193-0159
TEL: 518-797-3791

PA DEPARTMENT OF TRANSPORTATION						
REVISIONS			PENNDOT FUEL TRUCK GROUNDING CABLE DIAGRAM			
NO.	DATE	BY	DRAWN BY	SCALE	N/A	EQN-88
1	07-18-07	KNH				
2			DLW			
3			DATE	08-15-97	CHK'D BY	WHM
SHEET 1 OF 1						

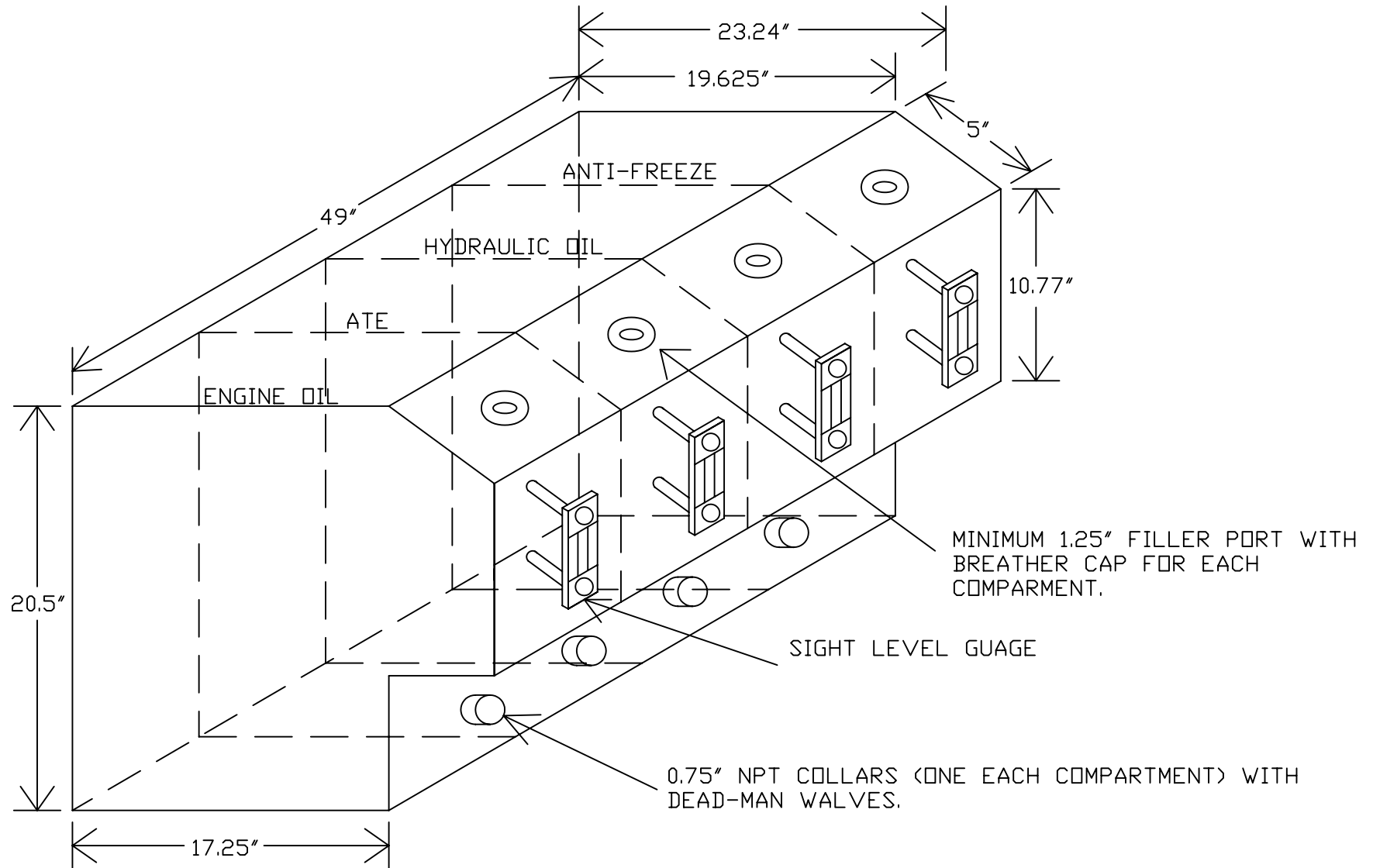

3/4" OD STAINLESS STEEL PIPE THROUGH THREE COMPARTMENTS FOR SUPPLY AND RETURN OF ENGINE HEATER HOSES.

EACH COMPARTMENT SHALL BE LABELED WITH A PERMANENT TYPE LABEL. STAINLESS STEEL TANK WITH MINIMUM 3/16" SIDES AND PARTITIONS. SIGHT LEVEL GAUGE SHALL BE FULL VISION, TRANSPARENT, BREAK RESISTANT NYLON SIGHT, FLUSH MOUNTED.

PA DEPARTMENT OF TRANSPORTATION					
REVISIONS			LUBE TRUCK AUXILIARY TANK DETAILS		
NO.	DATE	BY	DRAWN BY	SCALE	
1	07/15/99	GAH	WHM	N/A	EQN-89
2					
3			DATE 02/24/95	CHK'D BY RAR	SHEET 1 OF 2

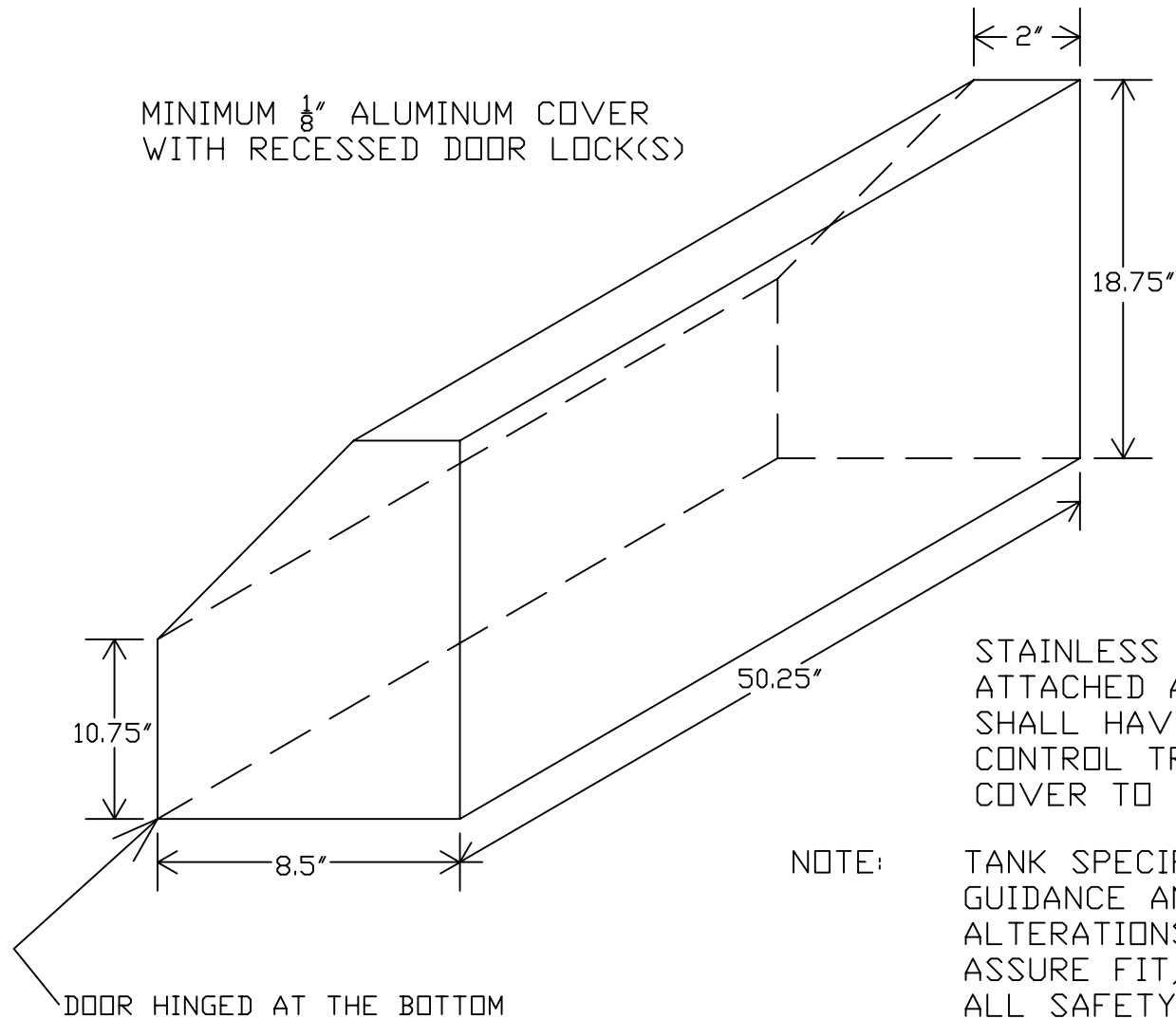

STAINLESS STEEL HINGE, CONTINUOUS ATTACHED AND WASHERS. COVER SHALL HAVE A RETAINER TO CONTROL TRAVEL AS TO NOT ALLOW COVER TO CONTACT THE GROUND.

NOTE: TANK SPECIFICATIONS ARE GIVEN AS GUIDANCE AND NECESSARY ALTERATIONS SHALL BE MADE TO ASSURE FIT, CLEARANCE AND TO MEET ALL SAFETY REQUIREMENTS.

PA DEPARTMENT OF TRANSPORTATION					
REVISIONS			LUBE TRUCK AUXILIARY TANK DETAILS		
NO.	DATE	BY	DRAWN BY	SCALE	
1	07/15/99	GAH			
2			WHM	N/A	EQN-89
3			02/24/95	RAR	SHEET 2 OF 2

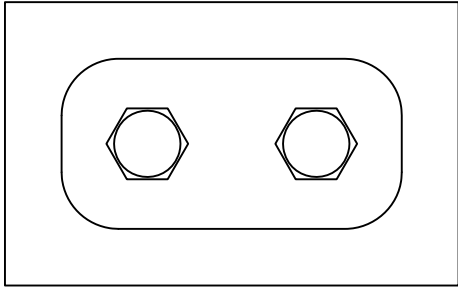

HYDRAULIC HOSES/ FITTINGS

HYDRAULIC HOSES SHALL NOT EXTEND BELOW THE TOP OF THE FRONT AXLE. ALL HYDRAULIC HOSES SHALL BE ADEQUATELY CLAMPED, SHIELDED FROM EXHAUST SYSTEM AND PREVENTED FROM RUBBING UP AGAINST ANY PART OF THE TRUCK FRAME BODY.

HYCON CLAMPS AS REQUIRED TO PREVENT CHAFFING OR RUBBING. DUE TO THE VARIATIONS OF SIZES PART NUMBERS HAVE NOT BEEN INCLUDED. WELD-ON OR BOLT-ON ARE ACCEPTABLE. AVAILABLE IN STANDARD AND HEAVY DUTY SERIES. LOCATIONS TO BE APPROVED BY CHIEF, EQUIPMENT DIVISION
 REF: HYCON CORPORATION, LEHIGH VALLEY, PA, PHONE: 800-755-0546

OR

BEHRINGER PIPE SYSTEM INC., TEL: 201-589-0546

NOTE:

ALL BOLTS/NUTS SHALL BE COATED WITH NEVER SIEZE.

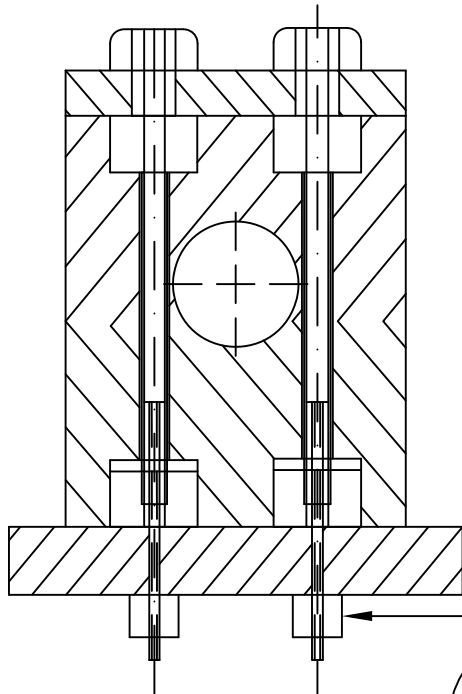

BOLT SHALL EXTEND BEYOND BASE

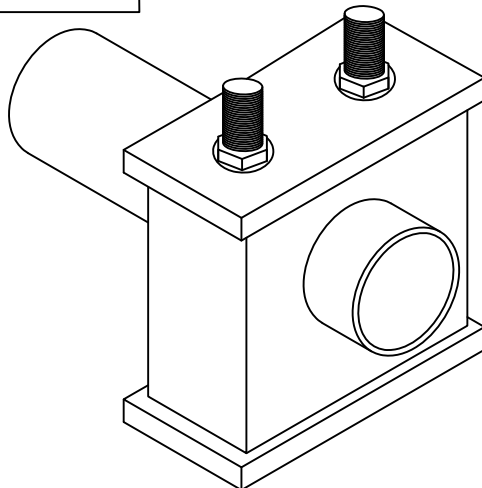

PA DEPARTMENT OF TRANSPORTATION

REVISIONS			HOSES AND CLAMPS HYCON		
NO.	DATE	BY	DRAWN BY	SCALE	
1	11-22-95	SWW			
2	08-15-97	DLW	LM	N/A	EQN-94
3	04-18-13	CJW	RED	11-03-78	SHEET 1 OF 2

SECTION 393.86 READS AS FOLLOWS:: "EVERY MOTOR VEHICLE, EXCEPT TRUCK-TRACTORS, POLE TRAILERS, AND VEHICLES IN DRIVEWAY-TOWAWAY OPERATIONS, THE DATE OF MANUFACTURE OF WHICH IS SUBSEQUENT TO DECEMBER 31, 1952, WHICH IS SO CONSTRUCTED THAT THE BODY OR THE CHASSIS ASSEMBLY IF WITHOUT A BODY HAS A CLEARANCE AT THE REAR END OF MORE THAN 30 in. FROM THE GROUND WHEN EMPTY, SHALL BE PROVIDED WITH BUMPERS OR DEVICES SERVING SIMILAR PURPOSES WHICH SHALL BE SO CONSTRUCTED AND LOCATED THAT: (A) THE CLEARANCE BETWEEN THE EFFECTED BOTTOM OF THE BUMPERS OR DEVICES AND THE GROUND SHALL NOT EXCEED 30 in. WITH VEHICLE EMPTY; (B) THE MAXIMUM DISTANCE BETWEEN THE CLOSEST POINTS BETWEEN BUMPERS, OR DEVICES, IF MORE THAN ONE IS USED, SHALL NOT EXCEED 24 in.; (C) THE MAXIMUM TRANSVERSE DISTANCE FROM THE WIDEST PART OF THE MOTOR VEHICLE AT THE REAR TO THE BUMPER OR DEVICE SHALL NOT EXCEED 18 in.; (D) THE BUMPER OR DEVICES SHALL BE LOCATED NOT MORE THAN 24 in. FORWARD OF THE EXTREME REAR OF THE VEHICLE; (E) AND THE BUMPER OR DEVICES SHALL BE SUBSTANTIALLY CONSTRUCTED AND FIRMLY ATTACHED. MOTOR VEHICLES CONSTRUCTED AND MAINTAINED SO THAT THE BODY, CHASSIS, OR OTHER PARTS OF THE VEHICLE AFFORD THE REAR END PROTECTION CONTEMPLATED SHALL BE DEEMED TO BE IN COMPLIANCE WITH THIS SECTION."

THE REGULATIONS ALSO REQUIRE ALL MOTOR VEHICLES TRANSPORTING HAZARDOUS MATERIALS REQUIRING PLACARDING BE EQUIPPED WITH REAR END PROTECTION (REFERENCE 49CFR PART 397, 49 CFR SECTION 177.823, 49 CFR PART 172, AND 49 CFR SECTION 171.12A).

ALTHOUGH SECTION 393.86 DOES NOT SET FORTH SPECIFIC PERFORMANCE REQUIREMENTS FOR THE REAR END PROTECTION STRUCTURE, SUBPART J - SPECIFICATIONS FOR CONTAINERS FOR MOTOR VEHICLE TRANSPORTATION OF PART 178 - SHIPPING CONTAINER SPECIFICATIONS OF SUBCHAPTER C - HAZARDOUS MATERIAL REGULATIONS OF CHAPTER I - RESEARCH AND SPECIAL PROGRAMS ADMINISTRATION DOES CONTAIN SPECIFIC PERFORMANCE REQUIREMENTS FOR REAR END PROTECTION ON CARGO TANK MOTOR VEHICLES (REFERENCE SECTIONS 178.337-10(D), 178.338-10(C), 178.345-8(D), 178.346-8, 178.347-8, AND 178.348-8). PENNSYLVANIA HAS ADOPTED 49 CFR 393.86 REAR END PROTECTION FOR COMMERCIAL MOTOR VEHICLES WITH A GVW OF 17,000 lbs. / 7711.07 kg. OR MORE OPERATED IN INTRASTATE COMMERCE, AND ANY SIZE VEHICLE HAULING HAZARDOUS MATERIALS REQUIRING PLACARDS WITH AN ADDITIONAL REQUIREMENT: "SOME PART OF THE HORIZONTAL BUMPER BAR SHALL FALL WITHIN 16-30in. / 40.64-76.2cm. ABOVE GROUND LEVEL." SEE TITLE 67 CHAPTER 175 OF THE PENNSYLVANIA CODE FOR THE SPECIFIC REQUIREMENTS FOR REAR END PROTECTION ON COMMERCIAL MOTOR VEHICLES WITH A GVW OF 10,001-17,000 lbs. / 4536.38-7711.07 kg. OPERATED IN INTRASTATE COMMERCE.

**ANY / ALL REVISIONS SHALL
SUPERSEDE THE ABOVE**

COMMONWEALTH OF PENNSYLVANIA DEPARTMENT OF TRANSPORTATION							
REVISIONS			UNDERRIDE PROTECTION				
NO.	DATE	BY					
1	07/08/97	DLW					
2	07/01/03	KGK	DRAWN BY	DLW	SCALE	N/A	EQN -118
3	06/26/09	TOD	DATE	02-04-92	CHK'D BY	RR	SHEET 1 OF 1

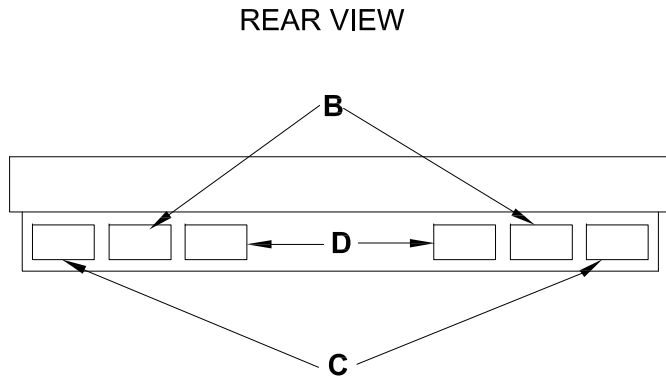
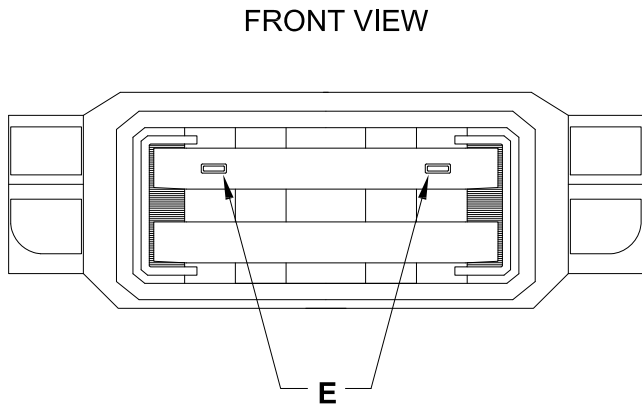

The purpose of this drawing is to show locations for Body Lighting, Whelen part # PADOTSY8.

- A. LINZ6AD Amber Warning Light, grommet (flush) mounted, one each side.
- B. M6BUD Back up Lights with Brush Guards.
- C. M5BTTD Stop / Tail / Turn Lights with Brush Guards.
- D. M6AD Amber Warning Lights with Brush Guards.
- E. LINZ6AD Amber Warning Light, both grommet mounted (flush with Front Grill).
- F. R10PADOT, R10-Mini Bar Warning Light.

**PLATFORM MOUNTED
LED LIGHT BAR & ANTENNA HOLE**

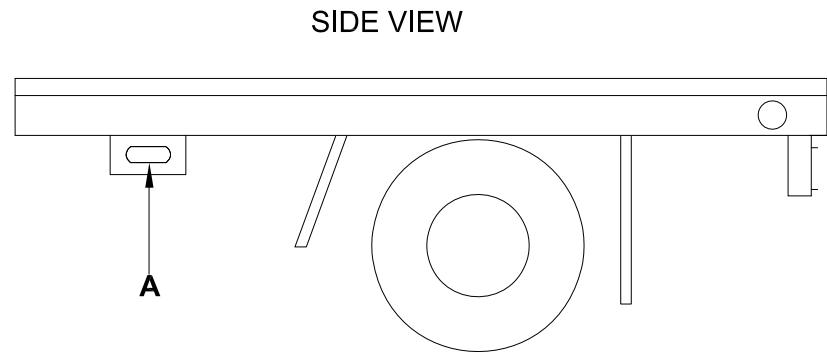
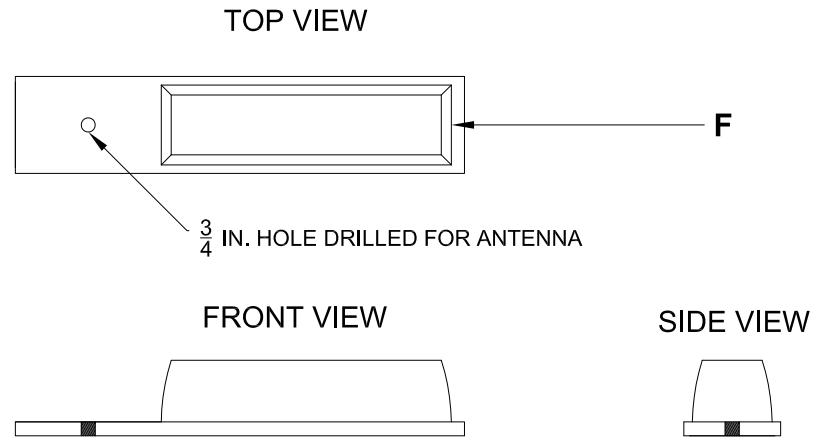

PA DEPARTMENT OF TRANSPORTATION

REVISIONS			UNIVERSAL TRUCK LIGHTING		
NO.	DATE	BY	DRAWN BY	SCALE	N/A
1	08-06-12	MJW	TOD	N/A	EQN-120Q
2			DATE	CHK'D BY	TOD
3					SHEET 1 OF 1

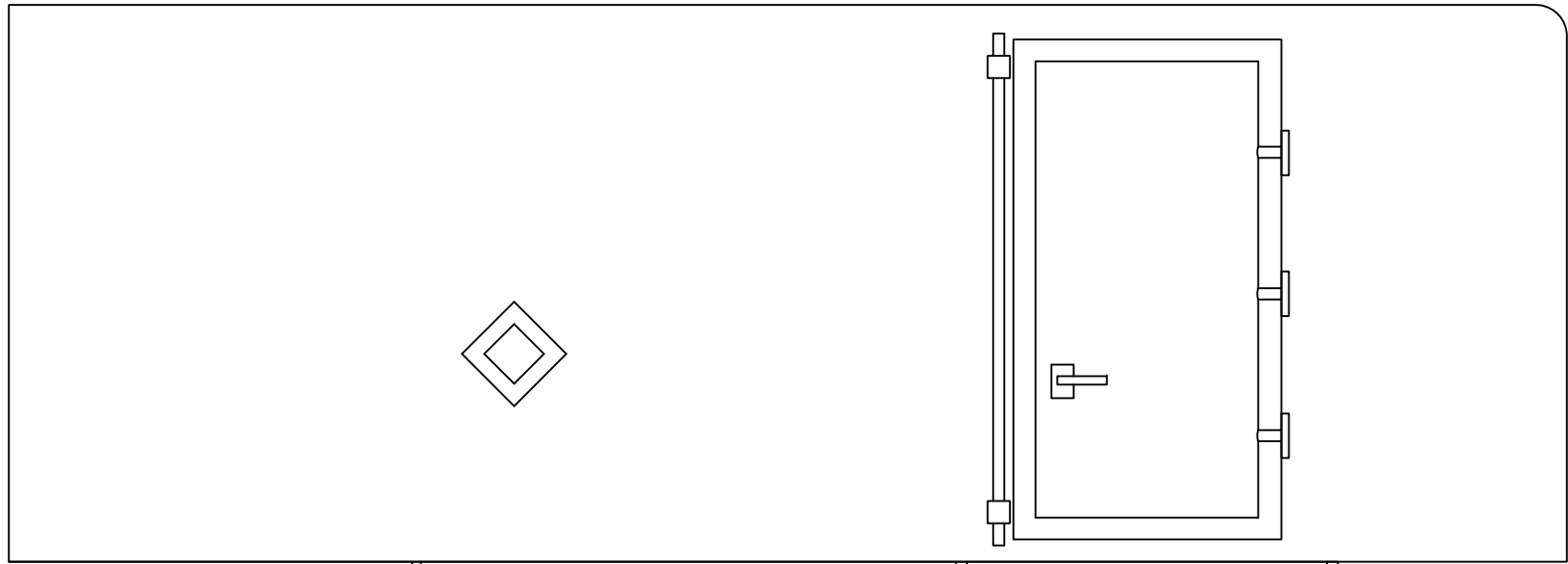

SIDE VIEW

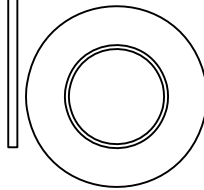

BACK VIEW

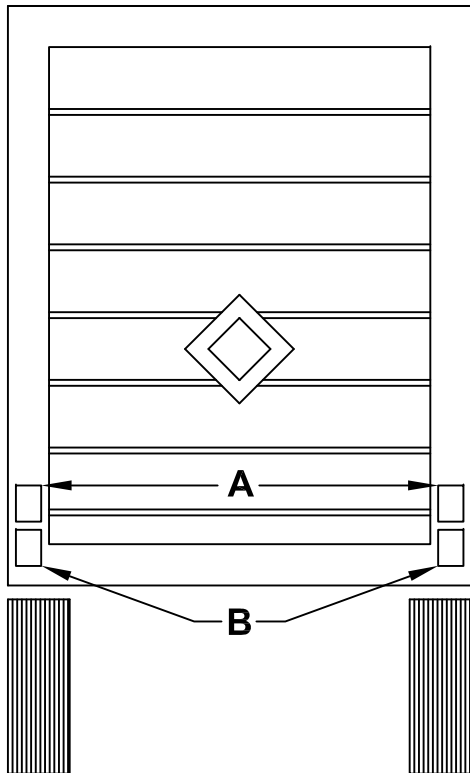

The purpose of this drawing is to show locations for Pony Truck Lighting.

- A. M6BUD Back up Lights with Brush Guards.
- B. M5BTDD Break / Tail / Turn Lights with Brush Guards.

PA DEPARTMENT OF TRANSPORTATION

REVISIONS			PONY TRUCK LIGHTING SYSTEM 9		
NO.	DATE	BY	DRAWN BY	SCALE	
1			MJW	N/A	EQN-120T
2					
3			DATE 07-31-12	CHK'D BY N/A	SHEET 1 OF 1

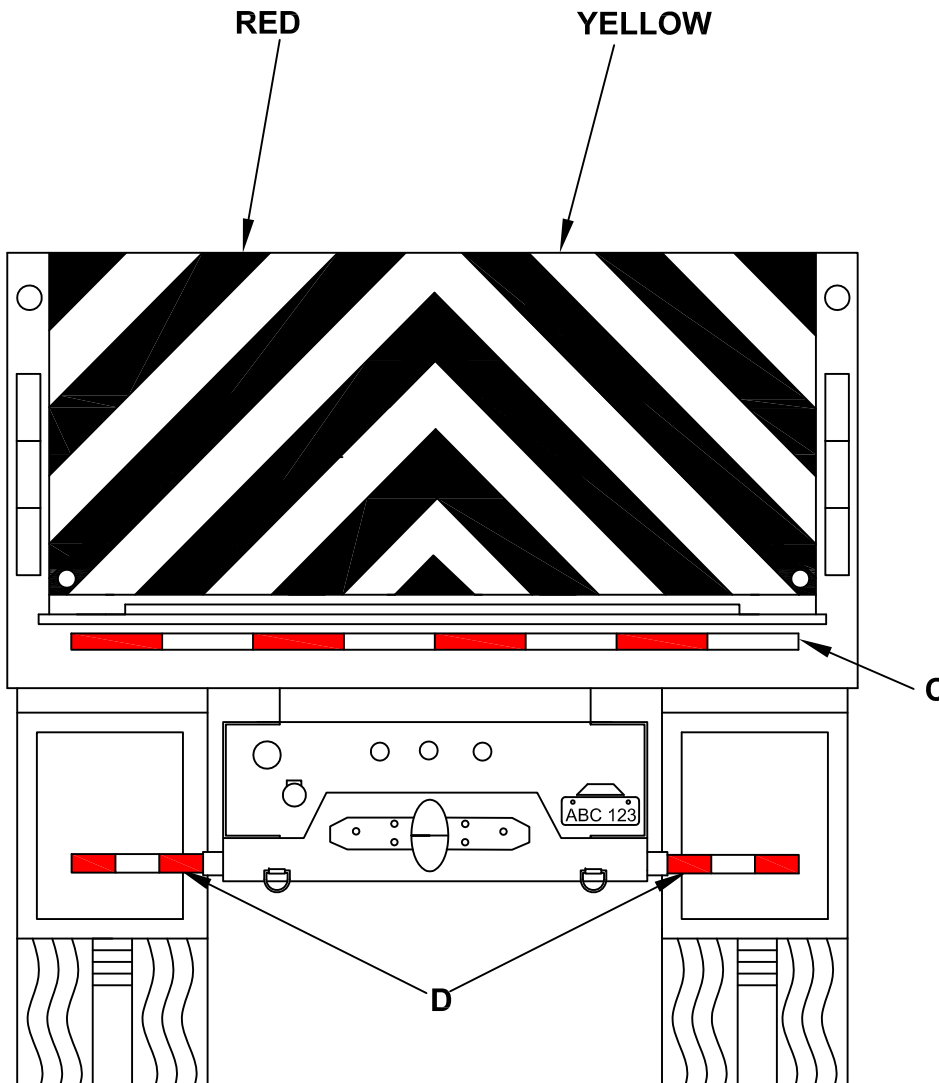

A THE ALUMINUM TAILGATE SHALL BE UNPAINTED. THE TAILGATE SHALL BE STRIPED AS SHOWN WITH 8" WIDE ALTERNATING RED/YELLOW BANDS CREATING A CHEVRON (INVERTED V) AT 45 DEGREE ANGLES, ACROSS THE GATE TO SERVE AS A SAFETY WARNING SYSTEM.

B TAPE SHALL BE REFLEXITE DAYBRIGHT V92 CONSPICUITY SHEETING. RED - SRHI4R PN# 18716, LIME - SRHI4Y PN# 18836 VC 312. TWO 4" SHEETS CAN BE COMBINED TO EQUAL THE 8" REQUIREMENT.

C THE ENTIRE WIDTH DIRECTLY UNDER THE TAILGATE SHALL BE COVERED WITH 1 1/2" WIDE SCOTCHLITE CONSPICUITY SHEETING SERIES 980 OR REFLEXITE CONSPICUITY II SYSTEM. MATERIAL SHALL BE RED/SILVER, CONTINUOUS BACKING.

D THE ENTIRE LENGTH OF BOTH ICC BARS SHALL BE COVERED WITH 1 1/2" WIDE SCOTCHLITE CONSPICUITY SHEETING SERIES 980 OR REFLEXITE CONSPICUITY II SYSTEM. MATERIAL SHALL BE RED/SILVER, CONTINUOUS BACKING.

THIS DRAWING SHALL BE FOR CONSPICUITY REFERENCE ONLY, NOT TAILGATE CONSTRUCTION.

THIS VEHICLE SHALL COMPLY WITH THE RULES OF THE NATIONAL HIGHWAY TRAFFIC SAFETY ADMINISTRATION (NHTSA). THE MOST CURRENT REGULATIONS SHALL BE ADHERED TO.

PA DEPARTMENT OF TRANSPORTATION

REVISIONS			DUMP BODY REFLECTIVE SHEETING		
NO.	DATE	BY			
1	12-23-09	PMK			
2	05-20-13	JFM	DRAWN BY	GRL	SCALE N/A
3	06-30-14	ACT	DATE	10-11-94	CHK'D BY RED
			EQN-122		
			SHEET 1 OF 2		

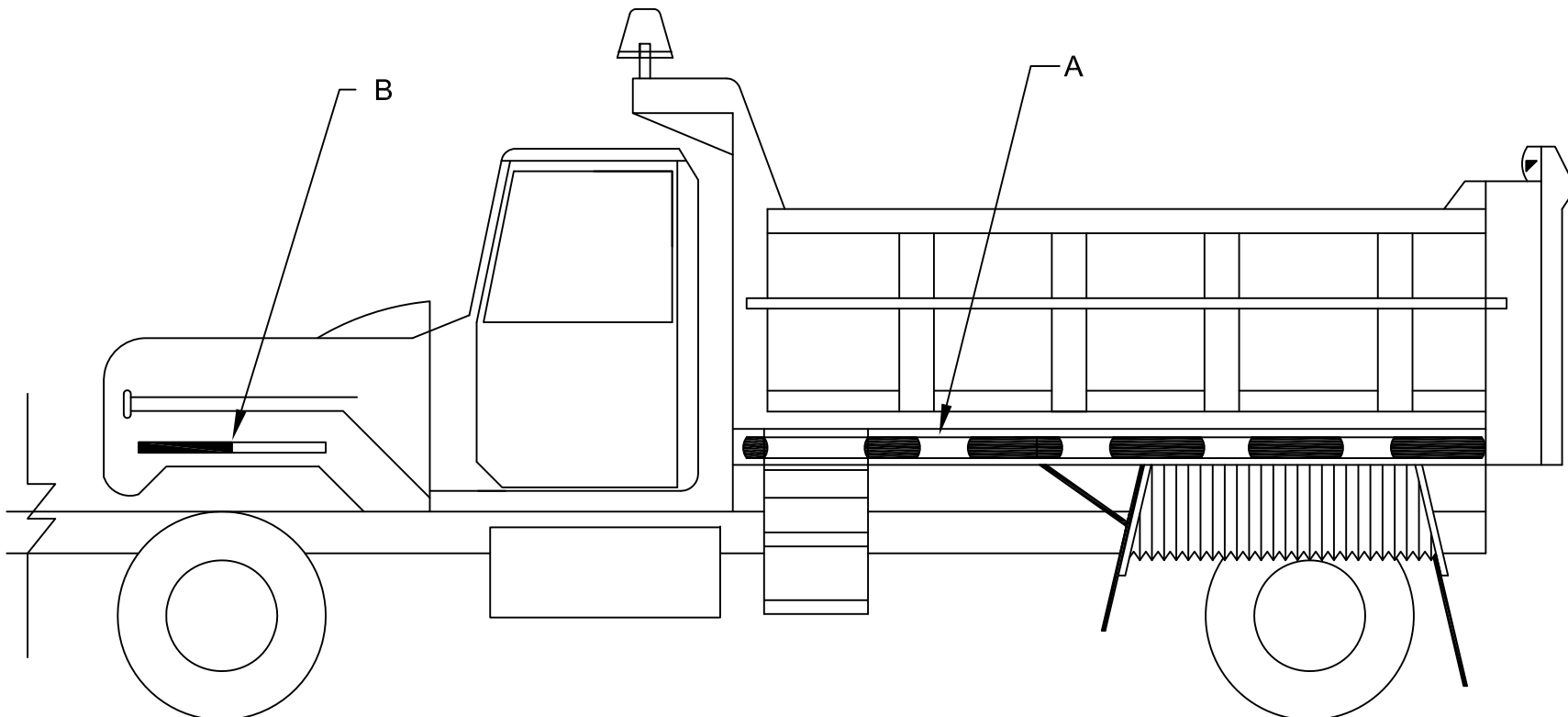

NOTE:

REFLECTORIZED 2" WIDE MARKING SHALL BE APPLIED. MATERIAL SHALL BE RED/SILVER CONTINUOUS BACKING REFLEXITE CONSPICUITY II SYSTEM OR 3m SCOTCHLITE CONSPICUITY SHEETING SERIES 980, OR GROTE CONSPICUITY TAPE.

ITEM A SHALL BE STRIPPED FULL LENGTH
 ITEM B SHALL BE STRIPPED IF A STRAIGHT CANBE USED IN CONJUNCTION WITH A.

PA DEPARTMENT OF TRANSPORTATION					
REVISIONS			CONSPICUITY TAPE & REDFLECTIVITY ENHANCEMENT		
NO.	DATE	BY	DRAWN BY	SCALE	
1	02-28-00	GAH			
2	05-16-02	DWG	GRL	N/A	EQN-127
3	03-01-07	CJW	DATE 12-02-94	CHK'D BY RED	SHEET 1 OF 1

THIS VEHICLE SHALL COMPLY WITH THE RULES OF THE NATIONAL HIGHWAY TRAFFIC SAFETY ADMINISTRATION (NHTSA) IN THAT:

THE MOUNTING HEIGHT OF THE HORIZONTAL STRIPES ARE RESTRICTED TO THE SAME HEIGHT AS OTHER RETROFLECTIVE DEVICES CURRENTLY REQUIRED BY STANDARD NUMBER 108. THE CENTER OF THE MATERIAL MUST NOT BE LESS THAN 15in. ABOVE THE ROAD SURFACE, AND THE UPPER EDGE NOT MORE THAN 60in. ABOVE IT.

REFLECTIVE MATERIAL SHALL BE APPLIED TO THE HORIZONTAL BAR OF THE REAR UNDERRIDE DEVICE IN ADDITION TO THE FLOOR LEVEL HORIZONTAL STRIPE. THE UPPER CORNERS ARE TO BE MARKED BY TWO 90 DEGREE ANGLE BRACKETS OF WHITE STRIPES 12in. BY TWO INCHES WIDE, INDICATING THE WIDTH AND HEIGHT OF THE TRAILER.

THE CONFIGURATION SHALL IDENTIFY THE VEHICLE AS TO ITS ESTIMATED SIZE AND THE CLOSEING DISTANCE TO IT. THE DISTRIBUTION OF SPACES AND MATERIALS SHALL BE AS UNIFORM AS PRACTICAL AND INDICATE THE FULL LENGTH AND WIDTH OF THE VEHICLE. THE COLORS SHALL BE PLACED IN ALTERNATING SEQUENCE WITH MORE THAN TWO-THIRDS OF THE MATERIAL IN COLOR.

CONSPICUITY TAPE SHALL BE REFLECTORIZED. 2in. WIDE, MATERIAL SHALL BE APPLIED. MATERIAL SHALL BE RED/SILVER CONTINUOUS BACKING REFLEXITE CONSPICUITY II SYSTEM OR 3M SCOTCHLITE CONSPICUITY SHEETING SERIES 980.

THE MOST CURRENT REGULATIONS SHALL BE ADHERED TO.

PA DEPARTMENT OF TRANSPORTATION					
REVISIONS			CONSPICUITY TAPE STRIPING REQUIREMENTS		
NO.	DATE	BY			
1	05-16-02	DWG			
2	11-03-06	CJW	<small>DRAWN BY</small> DLW	<small>SCALE</small> N/A	EQN-127A
3	01-02-09	MHH	<small>DATE</small> 11-07-97	<small>CHK'D BY</small> DMA	SHEET 1 OF 1

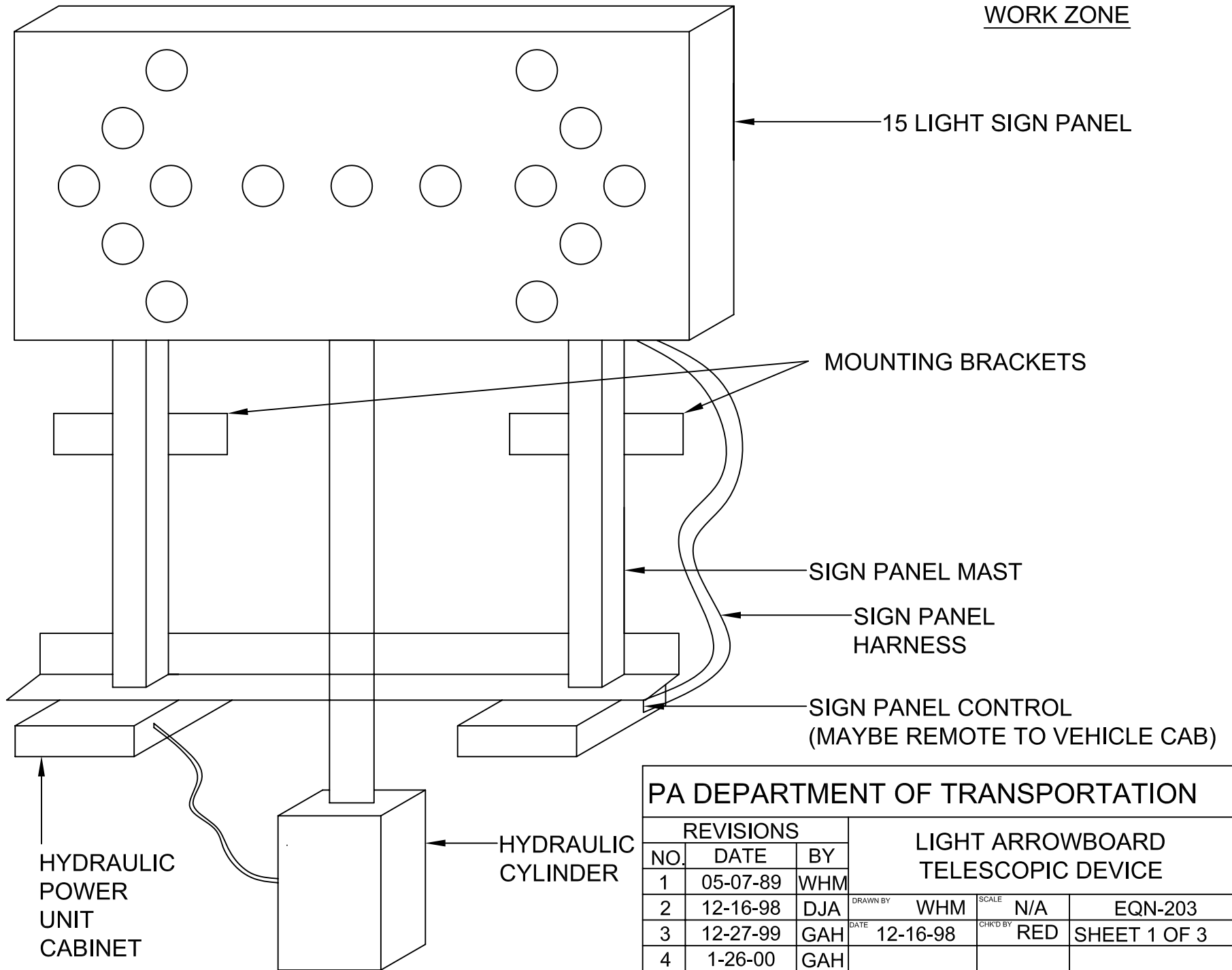

WORK ZONE

15 LIGHT SIGN PANEL

MOUNTING BRACKETS

SIGN PANEL MAST

SIGN PANEL HARNESS

SIGN PANEL CONTROL (MAYBE REMOTE TO VEHICLE CAB)

HYDRAULIC CYLINDER

HYDRAULIC POWER UNIT CABINET

PA DEPARTMENT OF TRANSPORTATION							
REVISIONS			LIGHT ARROWBOARD TELESCOPIC DEVICE				
NO.	DATE	BY	DRAWN BY	SCALE	N/A	EQN-203	
1	05-07-89	WHM					
2	12-16-98	DJA	WHM	12-16-98	RED		
3	12-27-99	GAH					
4	1-26-00	GAH					
5	11-17-06	CJW					

WORK ZONE

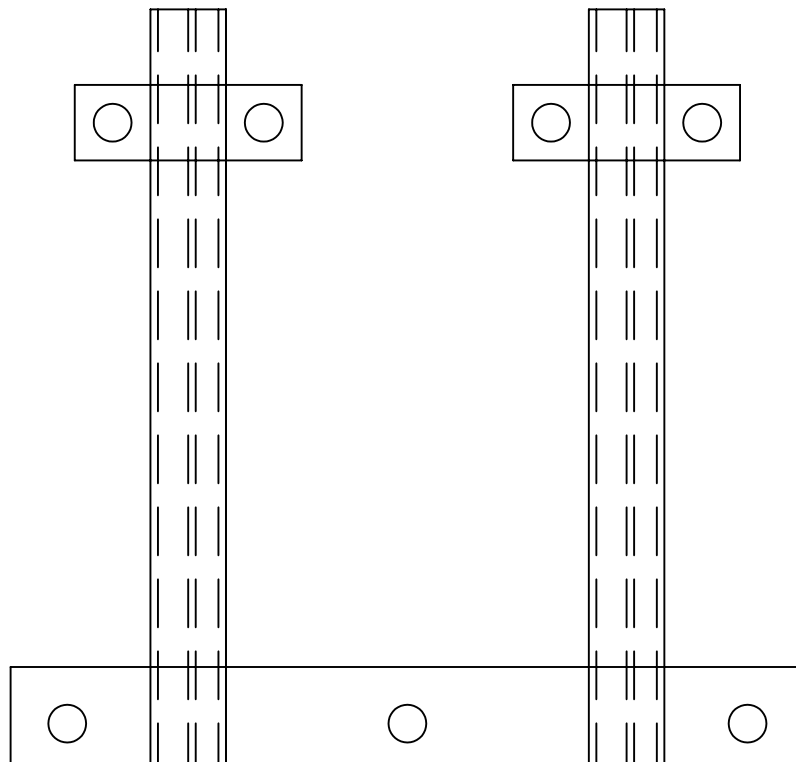
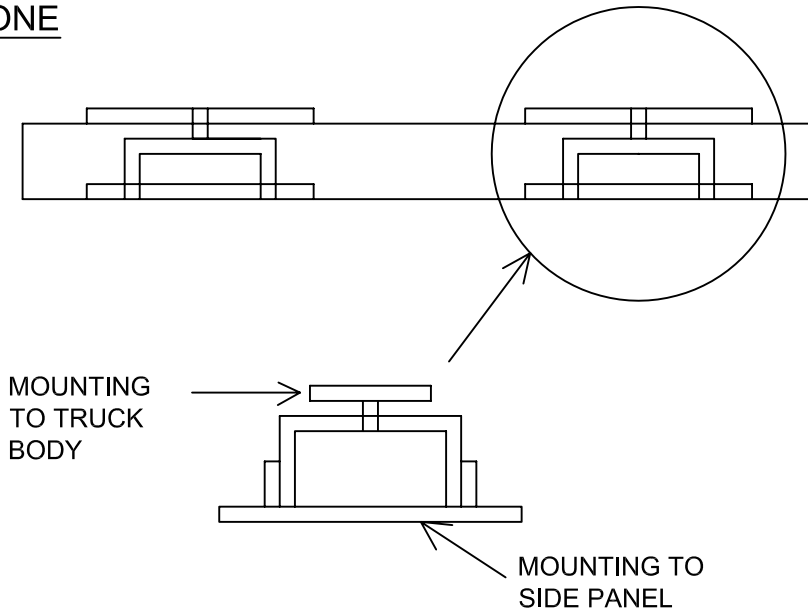

STRUCTURAL NOTES

1. BASE - 4"X2"X $\frac{3}{16}$ " STRUCTURAL ANGLE
2. OUTER TUBES - 2"X2"X $\frac{21}{8}$ " SEAMLESS STEEL TUBES
3. INNER TUBES - 1 $\frac{3}{4}$ "X1 $\frac{3}{4}$ "X $\frac{1}{8}$ " SEAMLESS STEEL TUBE
4. $\frac{3}{4}$ " SLOT CUT IN OUTER TUBE FOR SLIDE
5. $\frac{1}{2}$ "X1" BAR WELDED TO INNER TUBE AS A GUIDE
6. MTG BRACKETS WELDED TO INNER AND OUTER TUBES FOR MTG AS NECESSARY
7. INNER TUBE IS STATIONARY - OUTER TUBES FOR MTG AS NECESSARY
8. OUTER TUBE IS MOUNTED TO SIGN

HYDRAULIC SYSTEM NOTES

1. 500 LB LIFTING FORCE
2. SYSTEM PRESSURE - 400 PSI
3. FLOW - 2 GPM
4. CYLINDER - 1 $\frac{1}{2}$ " BORE
5. STROKE - 48"
6. TRAVEL TIME - 15 SECONDS
7. CYLINDER ACTIVATED VIZ 12V TOGGLE SWITCH MOUNTED IN SIGN PANEL CONTROL UNIT
8. SYSTEM FEATURES- OVER CENTER VALVE PIPED DIRECTLY INTO CYLINDER CAP END PORT TO LOCK CYLINDER INTO POSITION UNTIL PRESSURE IS APPLIED TO RED END PORT. VALVE ALSO ACTS TO RELIEVE THERMAL EXPANSION IN CYLINDER.

PA DEPARTMENT OF TRANSPORTATION

REVISIONS			LIGHT ARROWBOARD TELESCOPIC DEVICE		
NO.	DATE	BY			
1	05-07-89	WHM			
2	12-16-98	DJA	<small>DRAWN BY</small> WHM	<small>SCALE</small> N/A	EQN-203
3	12-27-99	GAH	<small>DATE</small> 12-16-98	<small>CHKD BY</small> RED	SHEET 2 OF 3
4	1-26-00	GAH			
5	11-17-06	CJW			

WORK ZONE

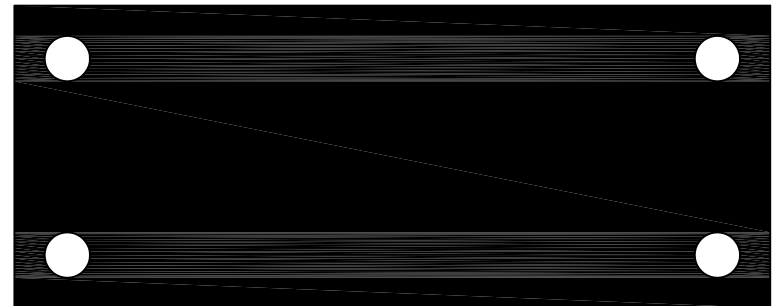
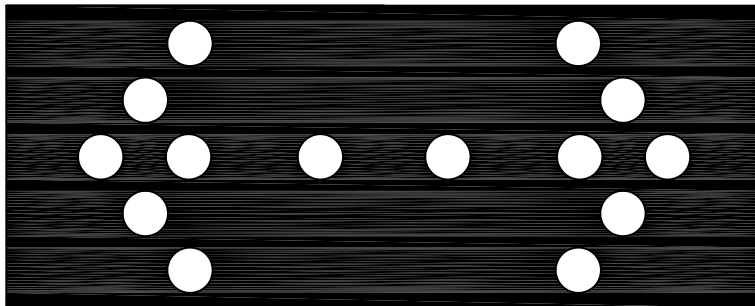
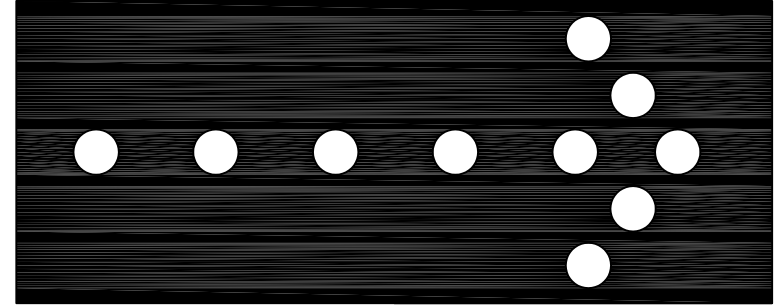
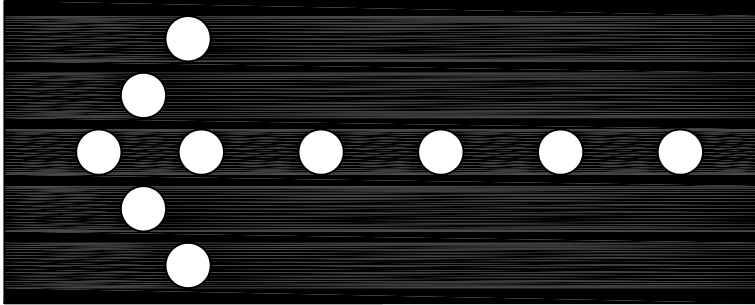

PA DEPARTMENT OF TRANSPORTATION						
REVISIONS			LIGHT ARROWBOARD TELESCOPIC DEVICE			
NO.	DATE	BY				
1	05-07-89	WHM				
2	12-16-98	DJA	<small>DRAWN BY</small> WHM	<small>SCALE</small> N/A		EQN-203
3	12-27-99	GAH	<small>DATE</small> 12-16-98	<small>CHK'D BY</small> RED		SHEET 3 OF 3
4	1-26-00	GAH				
5	11-17-06	CJW				

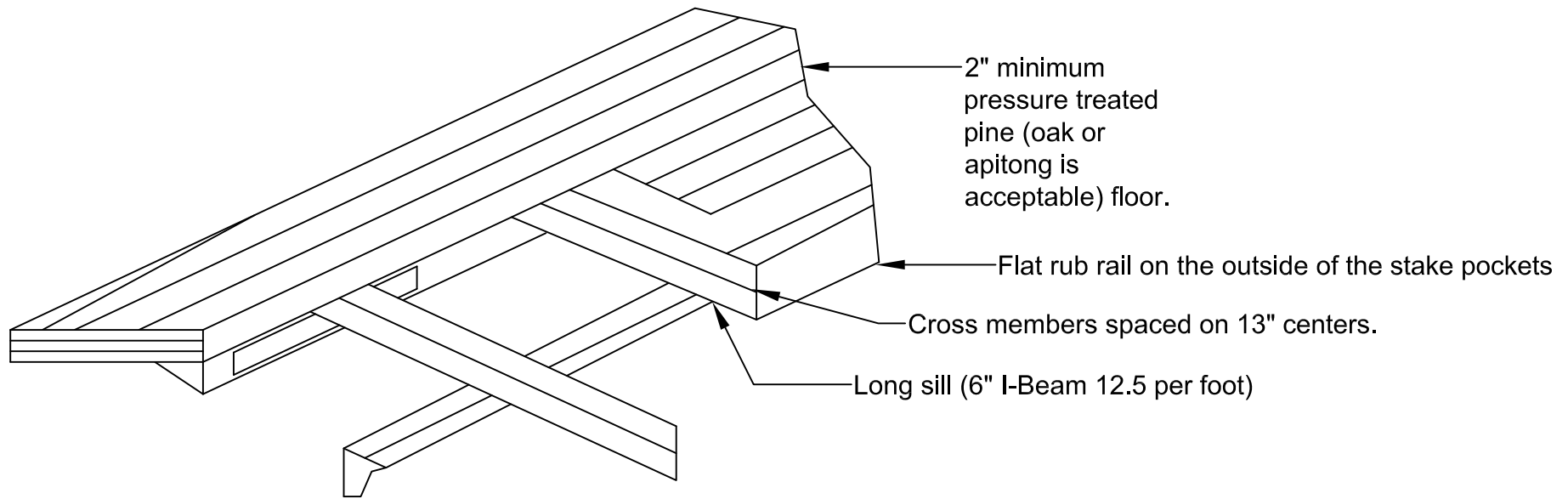

All markers and lights shall be installed in accordance with the PA State motor vehicle laws.

The front bulkhead shall have a screened window equal to the window of the truck chassis.

The truck frame AF shall incorporate a horizontal bumper and step reinforced with (2) vertical 6" underride channels and braced with (2) 4" channels back to the frame.

The platform body shall be attached to the truck frame with minimum $6\frac{5}{8}$ " U-bolts per side and self-locking nuts shall be utilized.

The platform body length shall be per invitation to bid.

PA DEPARTMENT OF TRANSPORTATION						
REVISIONS			PLATFORM BODY DETAILS			
NO.	DATE	BY				
1	05-21-02	DWG				
2	03-31-04	BLD	<small>DRAWN BY</small> RAR	<small>SCALE</small> N/A	EQN-225A	
3	01-16-07	CJW	<small>DATE</small> 01-17-90	<small>CHK'D BY</small> WHM	SHEET 1 OF 1	

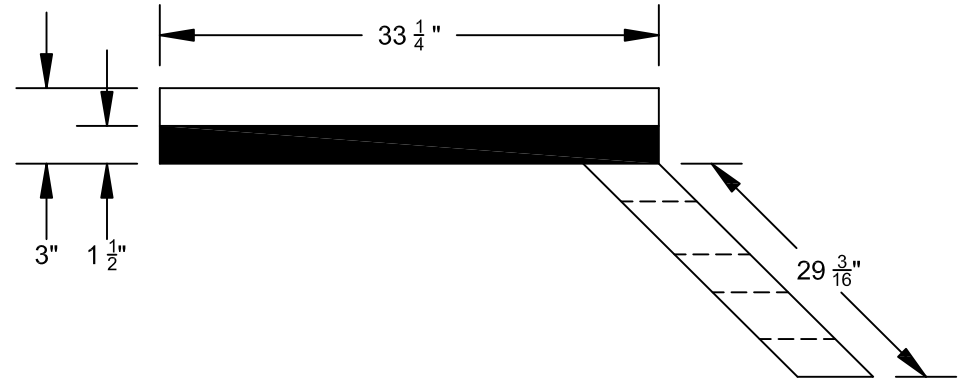
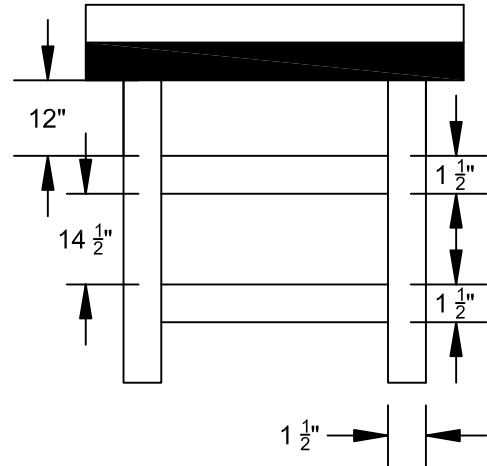
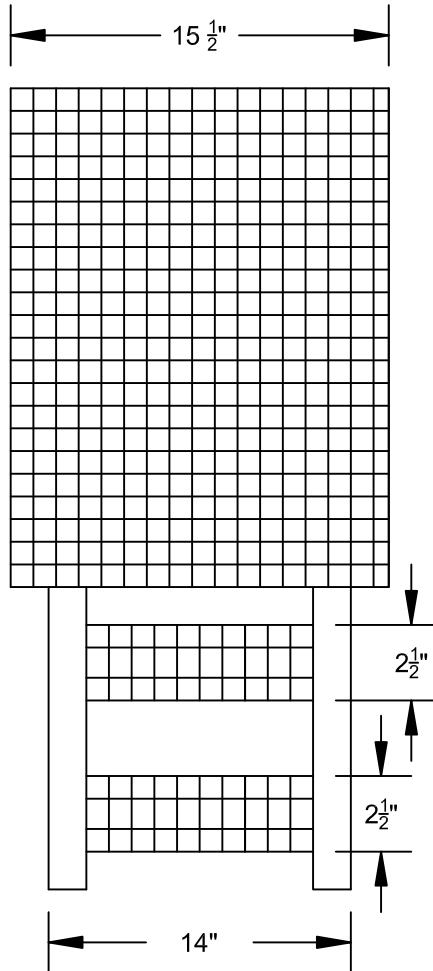

PA DEPARTMENT OF TRANSPORTATION					
REVISIONS			ENCLOSED LUBE & PONY TRUCK SIDE ENTRY STEP - PLATFORM		
NO.	DATE	BY	DRAWN BY	SCALE	
1	08-12-98	DJA			
2	05-23-07	KNH	AAD	N/A	EQN-229
3	06-11-14	ACT	DATE 06-16-89	CHK'D BY RED	SHEET 1 OF 2

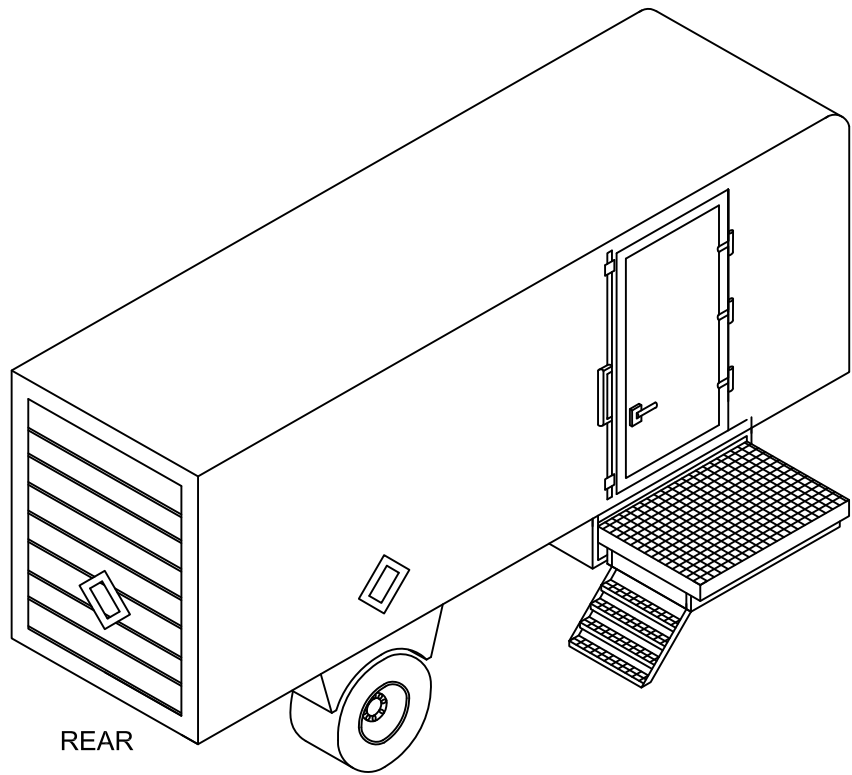

FRONT

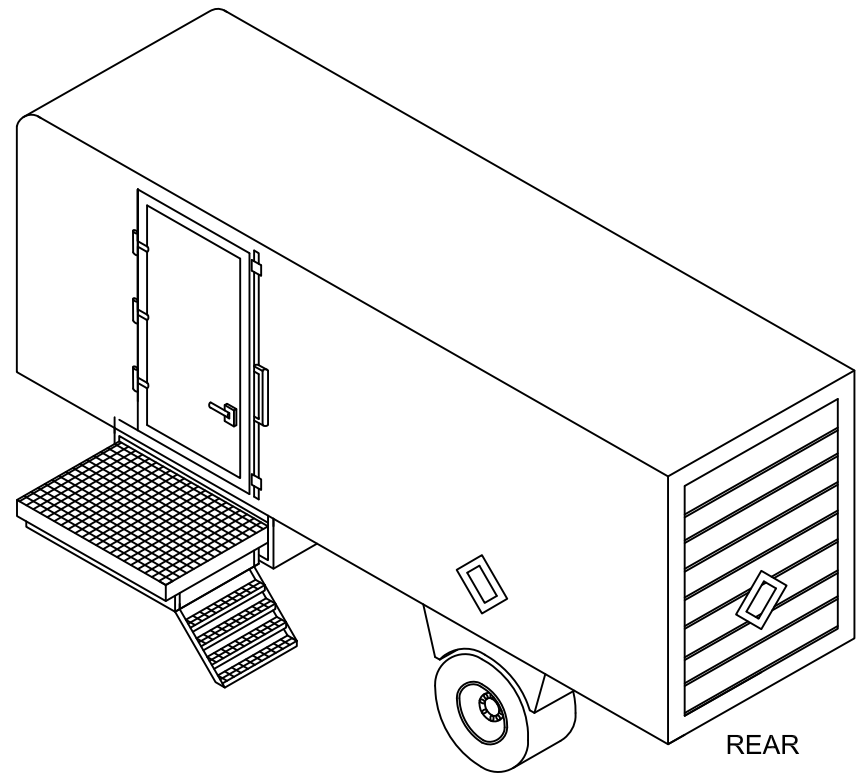

NOTES:

ALL DIMENSIONS ARE IN INCHES.

NOTE THIS REFERENCE FOR STEP AND PLATFORM: THE MATERIAL IS ALUMINUM. BUSTIN No. JAX119SG4 SERRATED SWAGE LOCK, WITH END BAND. THE SIZE AND STRENGTH SHALL BE IN ACCORDANCE WITH THE TRUCK MANUFACTURER'S STEP DESIGN BUT THE MATERIAL SHALL BE AS NOTED ABOVE. THE OUTER STEP EDGE MUST BE SERRATED IN LIEU OF PLAIN SMOOTH METAL EDGE. ALL EDGES SHALL BE BANDED (SKIRTING) ON THE OUTER PERIMETER. OVERLAY NOT ACCEPTABLE.

PA DEPARTMENT OF TRANSPORTATION

REVISIONS			ENCLOSED LUBE & PONY TRUCK SIDE ENTRY STEP - PLATFORM		
NO.	DATE	BY	DRAWN BY	SCALE	
1	08-12-98	DJA			
2	05-23-07	KNH	AAD	N/A	EQN-229
3	06-11-14	ACT	DATE 06-16-89	CHK'D BY RED	SHEET 2 OF 2

SPECIFICATIONS

FUEL TANK CATWALK AND OPERATOR PLATFORM

LOCATION: DRIVER'S SIDE ONLY SHALL BE POSITIONED TO PERMIT AN AVERAGE HEIGHT MAN TO REACH AND SERVICE THE TWO (2) FUEL MANHOLES IN THE STANDING POSITION.

DIMENSIONS: FULL TANK LENGTH, APPROXIMATELY 9" TO 10" WIDE, BUT SHALL NOT INCREASE THE LEGAL OVERALL VEHICLE WIDTH OF 96".

SAFETY" THE TANK MANUFACTURER SHALL WELD A PLATE TO THE TANK STRAP SO A SAFE AND LEGAL INSTALLATION OF THE REFERENCED SAFETY - STEPS CAN BE OBTAINED. WELDING TO THE TANK SAFETY OUTER LINER IS ACCEPTABLE.

HELPS: THE TANK MANUFACTURER SHALL SUPPLY THE STEP MANUFACTURER A DRAWING OF THE TANK TO ENSURE THE DEPARTMENT A TOTALLY ENGINEERED PRODUCT.

MATERIAL: ALUMINUM.

THE PICTURE BELOW OF THE PROPOSED CATWALK MATERIAL IS A GUIDE. DEPARTMENT DESIRES THE ATTACHING BRACKET TO BE ONE PIECE, FULL LENGTH TO PERMIT UPPER AND LOWER WELDING TO THE TANK GUSSET PLATE.

REFERENCE:

BUSTIN NO. NST4 FULL SIZE OHIO GRATING NO. JA2119SG4 SERRATED OR IKG INDUSTRIES TYPE BS4 SERRATED SWAGE LOCK, WITH END BAND. THE SIZE AND STRENGTH SHALL BE IN ACCORDANCE WITH THE TRUCK MANUFACTURER'S STEP DESIGN, BUT THE MATERIAL SHALL BE AS NOTED ABOVE. THE OUTER STEP EDGE MUST BE SERRATED IN LIEU OF PLAIN, SMOOTH METAL EDGE. ALL EDGES SHALL BE BANDED (SKIRTING) ON THE OUTER PERIMETER. OVERLAY NOT ACCEPTABLE.

PA DEPARTMENT OF TRANSPORTATION						
REVISIONS			FUEL TANK CATWALK & OPERATOR PLATFORM			
NO.	DATE	BY	DRAWN BY	SCALE		
1	08-13-98	DJA				
2	05-21-02	DWG	SGT	N/A	EQN-231	
3	06-12-07	KNH	DATE 03-12-90	CHK'D BY RED	SHEET 1 OF 1	

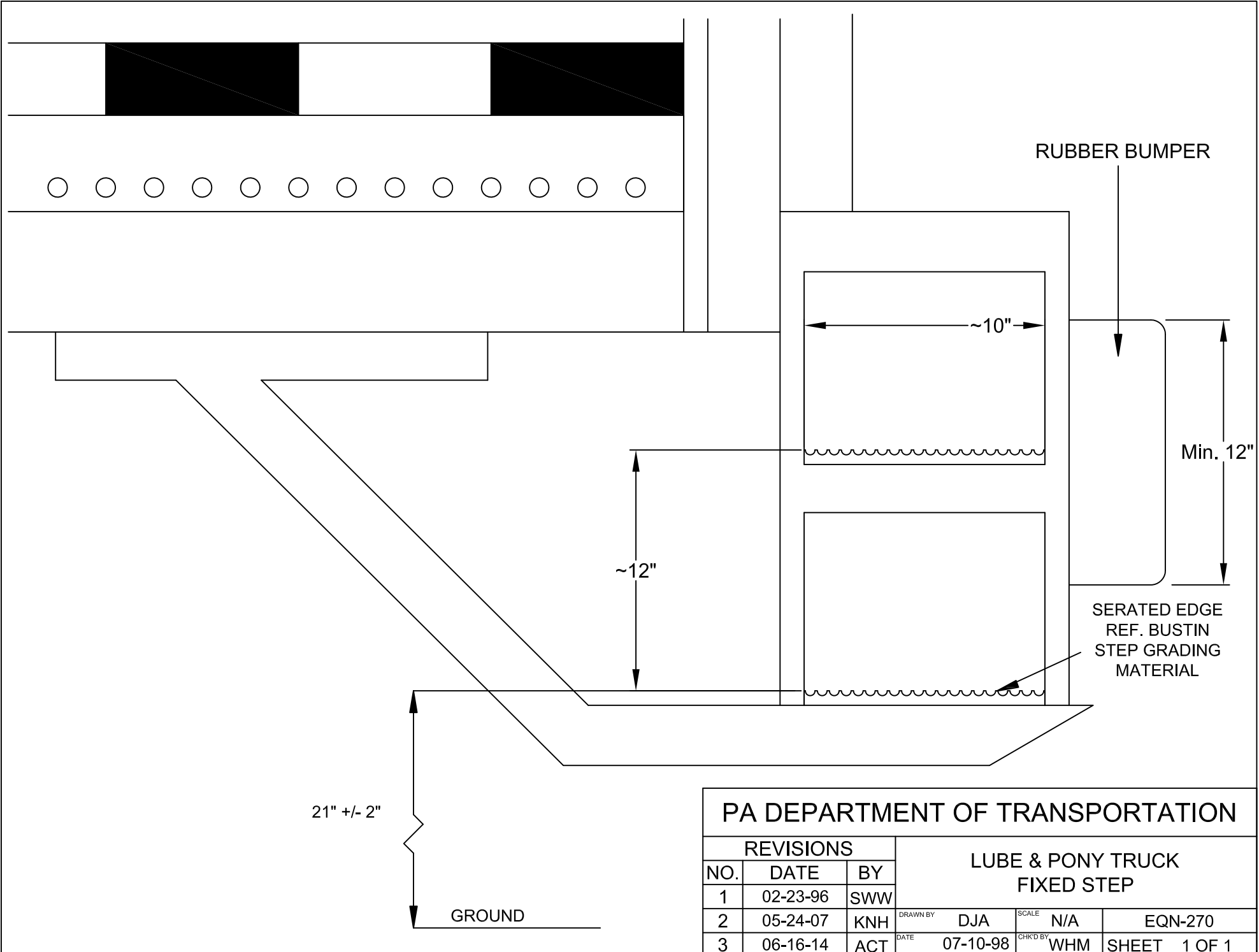

PA DEPARTMENT OF TRANSPORTATION					
REVISIONS			LUBE & PONY TRUCK FIXED STEP		
NO.	DATE	BY			
1	02-23-96	SWW			
2	05-24-07	KNH	DRAWN BY	DJA	SCALE N/A
3	06-16-14	ACT	DATE	07-10-98	CHK'D BY WHM
			EQN-270		
			SHEET 1 OF 1		

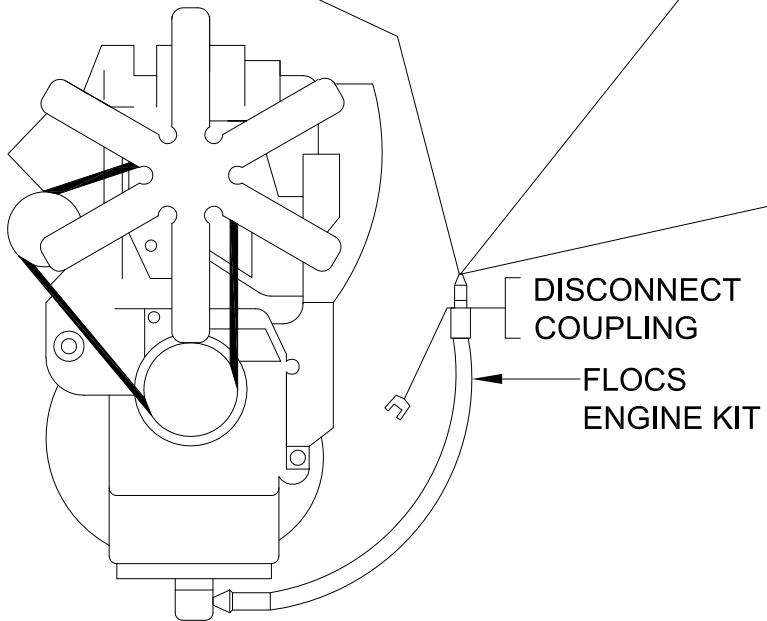
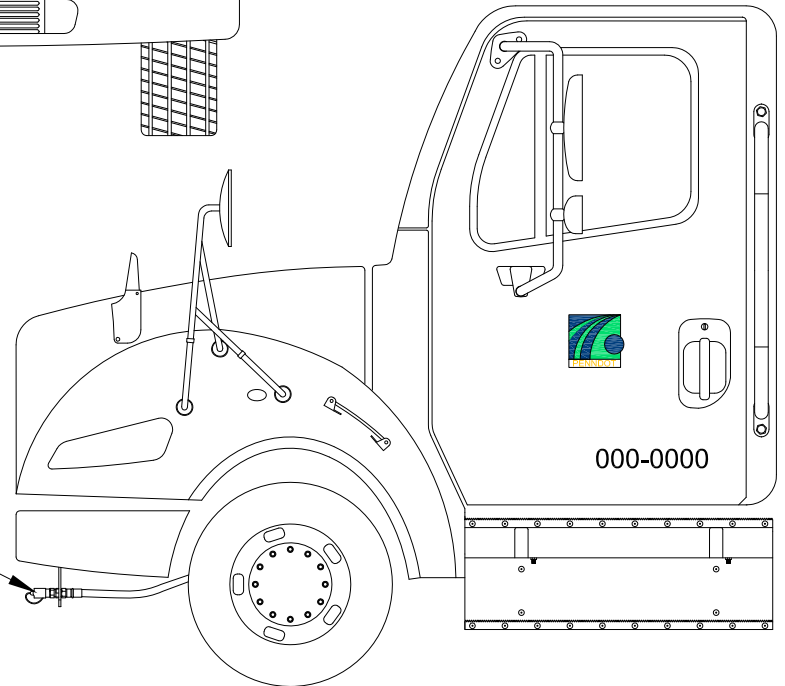
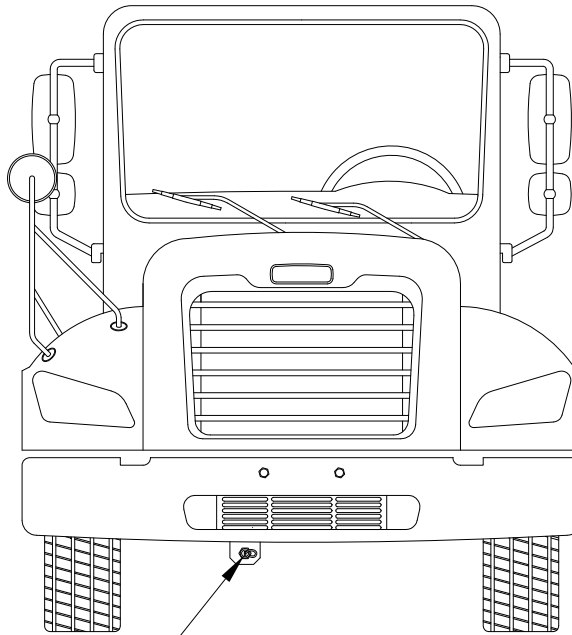
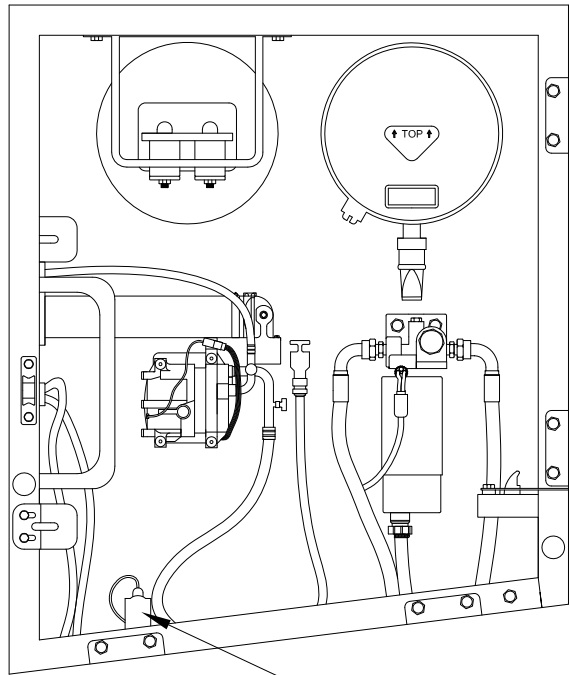

PA DEPARTMENT OF TRANSPORTATION						
REVISIONS			FAST LUBEOIL CHANGE SYSTEM OVERVIEW AND PARTS LIST			
NO.	DATE	BY	DRAWN BY	SCALE		
1	07-01-03	BLD				
2	10-20-06	CJW	DLW	N/A	EQN-351A	
3	06-19-13	JFM	08-22-97	WHM	SHEET 1 OF 2	

1. CONTACT AEROQUIP WITH YOUR DRAIN PAN PLUG SIZE
2. AEROQUIP DEALER TELEPHONE NUMBERS:

ADVANCED FLUID CONNECTORS.....717-757-1068
 AIR BRAKE & POWER EQUIPMENT CO..717-622-6188
 AMERICAN BEARING & POWER.....717-569-3291
 GOODALL RUBBER COMPANY.....610-534-2100
 POWER DRIVES INC.....814-833-8181
 R L MILLER INC.....412-833-6800
 R L MILLER INC.....814-456-8900
 SRG/BEVCO.....610-358-3100
 VOTO MANUFACTURERS SALES CO....814-226-7101

FLOCS SHALL INCLUDE, BUT NOT LIMITED TO:

- A. DUST CAP 5657-12
- B. HOSE TO SUIT LENGTH
- C. HOSE FITTING TO SUIT
- D. ADAPTER TO SUIT
- E. HOSE CLAMP #900729-6
- F. BRACKET TO SUIT
- G. COUPLING 5602-12-12S

PA DEPARTMENT OF TRANSPORTATION							
REVISIONS			FAST LUBEOIL CHANGE SYSTEM OVERVIEW AND PARTS LIST				
NO.	DATE	BY	DRAWN BY	DLW	SCALE	N/A	EQN-351A
1	07-01-03	BLD					
2	10-20-06	CJW	DATE	08-22-97	CHK'D BY	WHM	SHEET 2 OF 2
3	06-19-13	JFM					

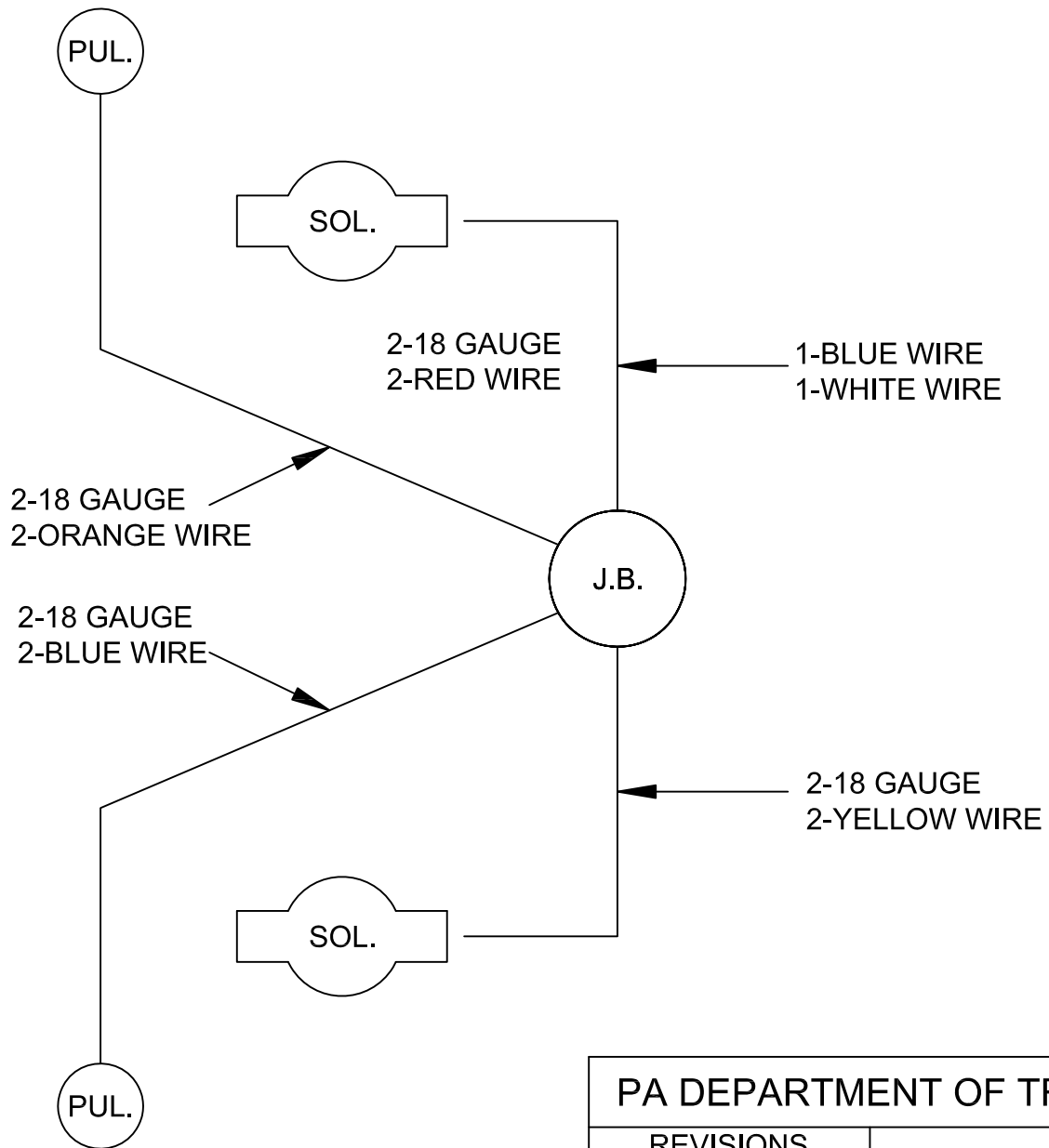

PA DEPARTMENT OF TRANSPORTATION					
REVISIONS			FUEL TRUCK		
NO.	DATE	BY			
1	07-17-01	DWG			
2	04-25-07	KNH	<small>DRAWN BY</small> WHM	<small>SCALE</small> N/A	EQN-352A
3	08-10-12	MJW	<small>DATE</small> 05-18-90	<small>CHK'D BY</small> RAR	SHEET 3 OF 3

PENNDOT FUEL TANK TRUCK TANK CATWALK

LOCATION: DRIVER'S SIDE ONLY AND SHALL BE POSITIONED TO PERMIT AN AVERAGE HEIGHT MAN TO REACH AND SERVICE THE TWO(2) FUEL MANHOLES IN THE STANDING POSITION.

DIMENSIONS: FULL TANK LENGTH, APPROX. 9 TO 10 INCHES WIDE, BUT SHALL NOT EXCEED THE LEGAL OVERALL VEHICLE WIDTH OF 96 INCHES.

SAFETY: THE TANK MFG. SHALL WELD A PLATE TO THE TANK SO A SAFE AND LEGAL INSTALLATION OF THE REFERENCED SAFETY STEPS CAN BE OBTAINED BY MEANS OF WELDING TO THIS AFORMENTIONED TANK OUTER LINER.

THE TANK MFG. SHALL SUPPLY THE REFERENCED STEP MFG. A DRAWING OF THE SUCESSFUL TANK MFGS. RADIUS, TO INSURE THE DEPARTMENT A TOTALLY ENGINEERED PRODUCT.

ATTACHMENT: THE PICTURE BELOW OF THE PROPOSED CATWALK MATERIAL IS A GUIDE. THE DEPT. DESIRES THE ATTACHING BRACKET TO BE ONE PIECE, FULL LENGTH, TO PERMIT UPPER AND LOWER WELDING TO THE TANK GUSSETT PLATE.

AS MFG. BY: Bustin Industrial Products Inc.
P.O. Box 826
Dover, New Jersey 07801
Phone: (201)-366-8800

IKG
R.D. #2 Route 910
Cheswick, PA 15024
Phone: (412)-828-2223

Ohio Grating Inc.
5299 Southway SW
Canton, Ohio 44706-1992
Phone: (216)-477-6707

PA DEPARTMENT OF TRANSPORTATION						
REVISIONS			PENNDOT FUEL TRUCK TANK CATWALK LOCATION			
NO.	DATE	BY	DRAWN BY	SCALE		
1	07/02/01	DJA	DJA	N/A		EQN-352B
2	04-11-06	KNH	06/19/98	WHM		SHEET 2 OF 2

①

SHELTER TO PLATFORM SHALL BE RUBBER SHOCK MOUNTED

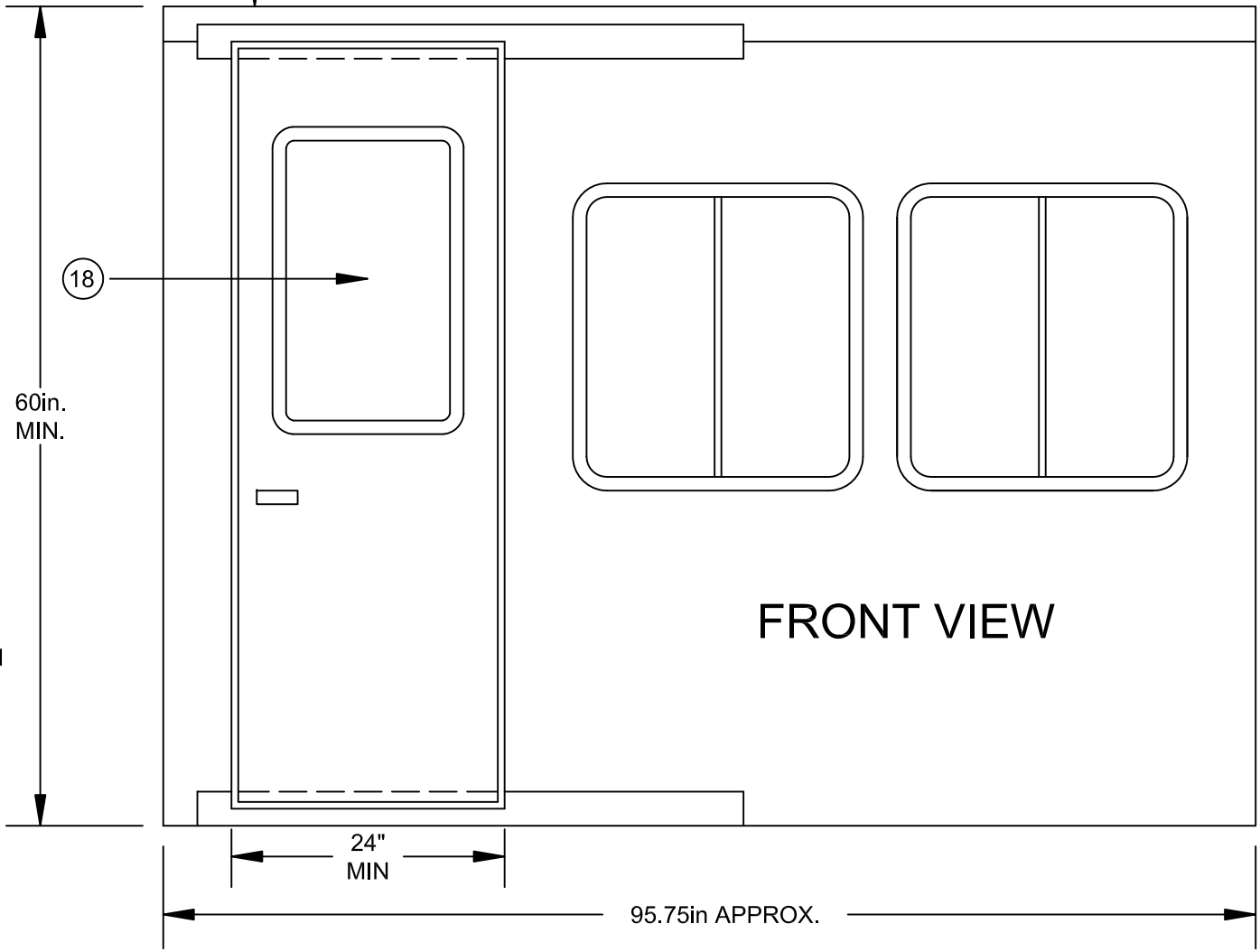

FRONT VIEW

PER INVITATION TO BID

WINDOW TRACKS SHALL BE ON THE OUTSIDE OR CONSTRUCTED IN SUCH A WAY AS TO NOT ALLOW WATER TO DRIP OR FLOW INTO THE INSIDE OF THE CAB. SIDE BUBBLE WINDOWS SHALL BE INSTALLED BY THE SUCCESSFUL VENDOR.

PA DEPARTMENT OF TRANSPORTATION

REVISIONS			PAINT TRUCK REAR SHELTER		
NO.	DATE	BY	DRAWN BY	SCALE	CHK'D BY
1	05-22-02	DWG	DLW	N/A	EQN-370
2	05-16-07	KNH	DLW	N/A	EQN-370
3	07-11-13	JFM	DLW	N/A	EQN-370

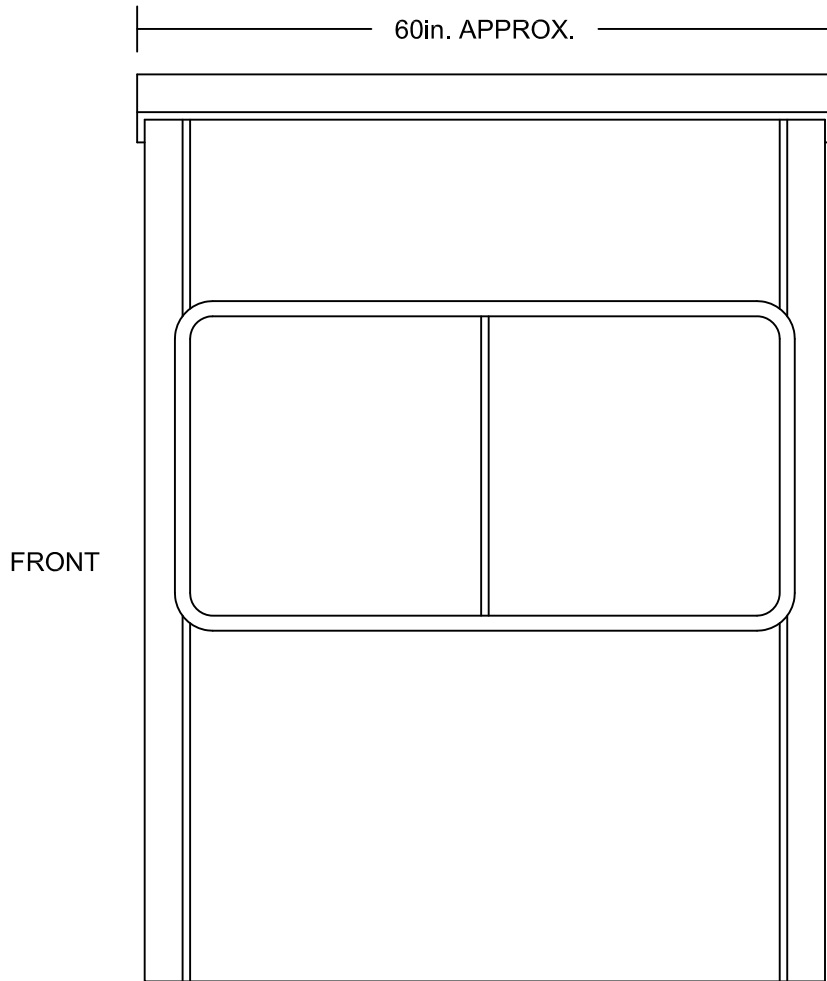

ASTI- I - TINTED AUTOMOTIVE GLASS

THE ENTIRE INSIDE OF STRUCTURE-WALLS AND ROOF SHALL BE COVERED IN SOUND DEADENING, INSULATING MATERIAL, REF.: ALLIED INSULATION COMPANY. 1" FOAM INSULATION, TAN PERFORATED VINYL WITH POLYESTER PAD. ALL SEAMS SHALL BE SILICONE SEALED.

DOORS SHALL BE FURNISHED WITH FULL LENGTH PIANO HINGES. THE HARDWARE SHALL BE FLUSH TYPE HEAVY-DUTY AUTOMOTIVE STYLE AND LOCKABLE WITH ALL LOCKS KEYED ALIKE. THE DOOR SHALL HINGE IN SUCH A MANNER AS NOT TO OBSTUCT THE OPERATORS MOUNTING OR DISMOUNTING FROM THE DECK AREA.

ALL WINDOW OPENING HEIGHTS IN RELATIONSHIP TO THE SEAT HEIGHTS SHALL PROVIDE A REASONABLE AND COMFORTABLE HEIGHT FOR OPTIMUM OPERATOR COMFORT.

REAR

19	PANE - SLIDING
18	PANE - DOOR
17	HANDLE - LOCK
16	LOCK - DOOR
15	BRACKET
14	HINGE - DOOR $\frac{1}{8}$ " PIN X 24"
1	PANE - SLIDING

31	WEATHER STRIP
30	LOCK - WINDOW
29	RUBBER - STRIP
28	MOLDING - WINDOW
27	CHANNEL FLEXIBLE
22	PANE - STATIONARY
21	PANE - SLIDING
20	PANE - SIDE, STATIONARY

SIDE VIEW

PA DEPARTMENT OF TRANSPORTATION

REVISIONS			PAINT TRUCK REAR SHELTER			
NO.	DATE	BY	DRAWN BY	SCALE	N/A	EQN-370
1	05-22-02	DWG				
2	05-16-07	KNH	DLW			
3	07-11-13	JFM	DATE 12-30-97	CHK'D BY WHM		SHEET 2 OF 3

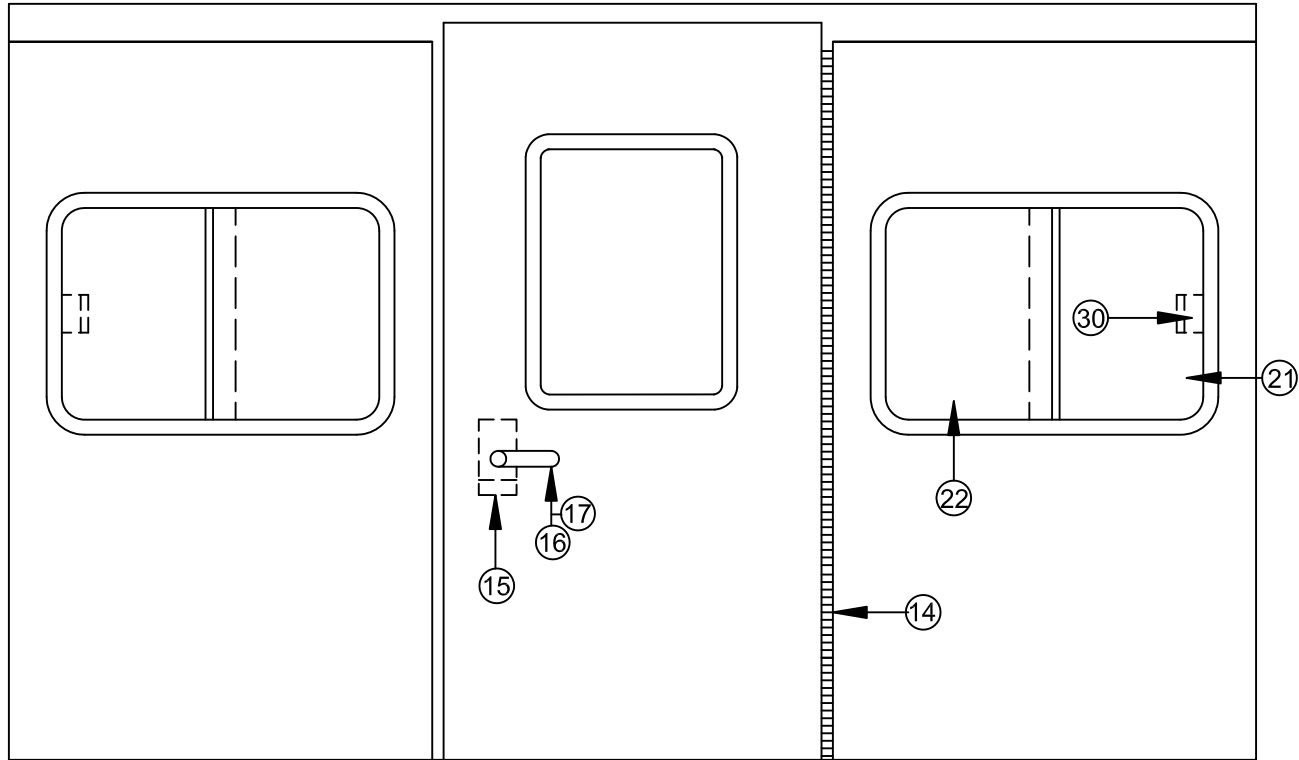

← 21in. MIN. →

REAR VIEW

PA DEPARTMENT OF TRANSPORTATION							
REVISIONS			PAINT TRUCK REAR SHELTER				
NO.	DATE	BY			SCALE		
1	05-22-02	DWG			N/A	EQN-370	
2	05-16-07	KNH	DRAWN BY	DLW			
3	07-11-13	JFM	DATE	12-30-97	CHK'D BY	WHM	SHEET 3 OF 3

Centralized Lubrication System On Road Equipment EQN - 501

There shall be an automatic centralized lubrication system professionally installed to maintain all the daily, weekly, and monthly lubrication points. Only electrically controlled, #2 chassis grease systems shall be accepted. The use of pneumatic systems is unacceptable. The requirements for the lubrication system components and installation procedures are outlined below. It is the responsibility of the vendor to ensure that the automatic lubrication system complies with all of these requirements.

1. Performance Requirements

- The system pump shall be capable of delivering NLGI #2 grease over a temperature range of minus 10 degrees Fahrenheit to 120 degrees Fahrenheit.
- The pump shall have an integral adjustable timer to change the grease delivery intervals as needed.
- The system shall use a fused electric pump, either 12 Volt DC or 24 Volt DC depending on application. Pneumatic pumps are not acceptable.
- The pump shall be equipped with a pressure relief valve device at the pump outlet to protect the pump from damage due to over pressure.
- For ease of service, the pump shall have a pumping element located on the side that can be removed and replaced or repaired as needed without having to remove or disassemble the pump.
- The pump shall use a clear or translucent reservoir to allow for visual inspection of the grease level. Reservoir shall have a full level indicator. Bladder type reservoirs are not acceptable.
- The grease reservoir shall be a minimum four pound capacity.
- The system shall have a cab mounted fault light that will notify the operator of a lube system fault and low grease level. If any point in the system will not take grease, the fault light shall illuminate.
- The system shall be a positive displacement series progressive type, using primary and secondary valves.
- All secondary valves shall be non-segmented to minimize the potential leak path and or sources of contamination.
- All valves shall be made of corrosion resistant coated carbon steel.
- The positive displacement proportioning valves shall have a tee and high back pressure grease fittings at each valve inlet for manual filling, system testing, and to fill repaired lines.
- The system shall have a manual override fitting to enable the system to be manually operated if the pump is inoperable.
- Equipment shall have a 2 year manufacturer's warranty.

2. Installation Requirements - On Road

- The system shall use only high pressure hose (4,000 psig operating, 10,000 psig burst). All hoses are to be of US standard sizes (1/8" ID hose 5/16 OD) and readily available from local sources.
- All hoses shall use a two piece re-usable hose end with quick disconnects at the valve outlet for ease of inspection and repair.
- All lines from the secondary valves to the chassis or body inlet points shall be flexible with at least a 500 PSI working pressure. All tubing shall be standard size (1/4 inch OD) and readily available from local sources.
- All line runs will be secured to the chassis or air lines via tie wraps. Protective wrap shall be used for all lines run over any edge of the chassis and especially at the termination points for front suspension including upper & lower king pins, tie rod ends and any exposed lines that are not fixed. The use of steel tubing is prohibited.
- The pump shall be installed in a safe location on the truck chassis that is protected and easy to monitor the grease level and refill. For exact mounting location, contact PennDOT Equipment Division, Specification Unit - 717.787.2123
- Ground Level filling shall be provided for all lube systems. Remote lines are acceptable if reservoir is viewable from remote fill location.
- Installations shall be warranted for 2 years of operation.

PA DEPARTMENT OF TRANSPORTATION				
REVISIONS			CENTRALIZED LUBE SYSTEM	
NO.	DATE	BY		
1			<small>SCALE</small> N/A	EQN-501
2			<small>DRAWN BY</small> TOD	
3			<small>DATE</small> 6-8-09	<small>CHK'D BY</small> SHEET 1 OF 2

MINIMUM TYPICAL LUBE POINTS TANDEM AXLE

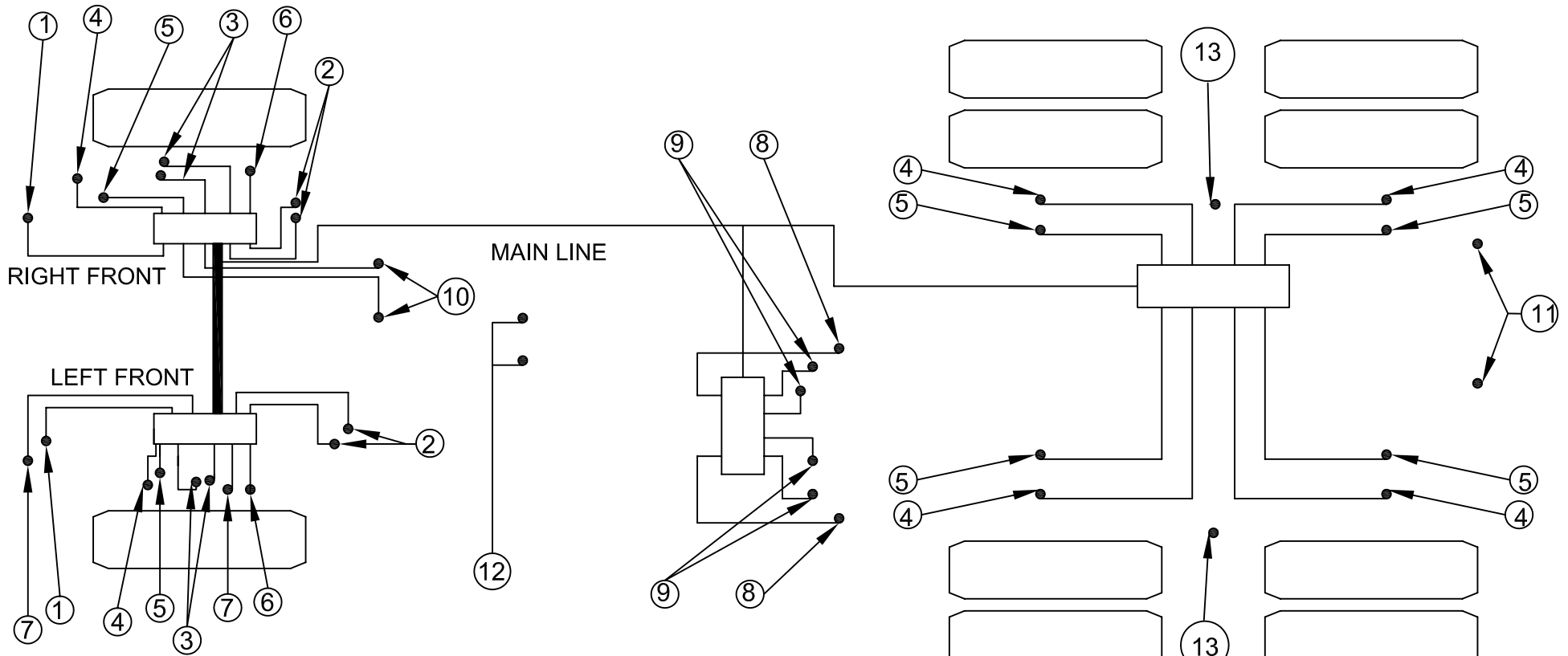

MINIMUM TYPICAL
VEHICLE LUBE POINTS.

*ALL LUBRICATION
POINTS SHALL BE
INCORPORATED INTO
THE ON-BOARD GREASE
SYSTEM. INCLUDING ALL
CHASSIS AND BODY
POINTS, EXCEPT
LOCATIONS RESTRICTED
BY ROTATING DESIGN; IE:
DRIVESHAFT & PTO

1. FRONT SPRING PIN
2. FRONT SPRING SHACKLES
(UPPER AND LOWER)
3. KING PIN (UPPER AND LOWER)
4. BRAKE CAM SHAFT
5. BRAKE SLACK ADJUSTER
6. TIE ROD
7. DRAG LINK
8. FIFTH WHEEL PIVOT (IF APPLICABLE)
9. FIFTH WHEEL PLATE (IF APPLICABLE)
10. CLUTCH CROSS SHAFT
11. REAR DUMP BED HINGE (1 EACH SIDE)
12. TOP AND BOTTOM OF HOIST CYL.

13. DEPENDING ON APPLICATION, ALL REAR SUSPENSION,
TRUNIONS, LEAF SPRINGS

PA DEPARTMENT OF TRANSPORTATION					
REVISIONS			CENTRALIZED LUBE SYSTEM GENERIC ARRANGEMENT		
NO.	DATE	BY	DRAWN BY	SCALE	EQUATION
1	12-15-00	GAH	GAH	N/A	EQN-501
2	01-02-07	CJW	DATE 8-31-99	CHKD BY LHA	SHEET 2 OF 2
3	06-09-09	TOD			
4					
5					

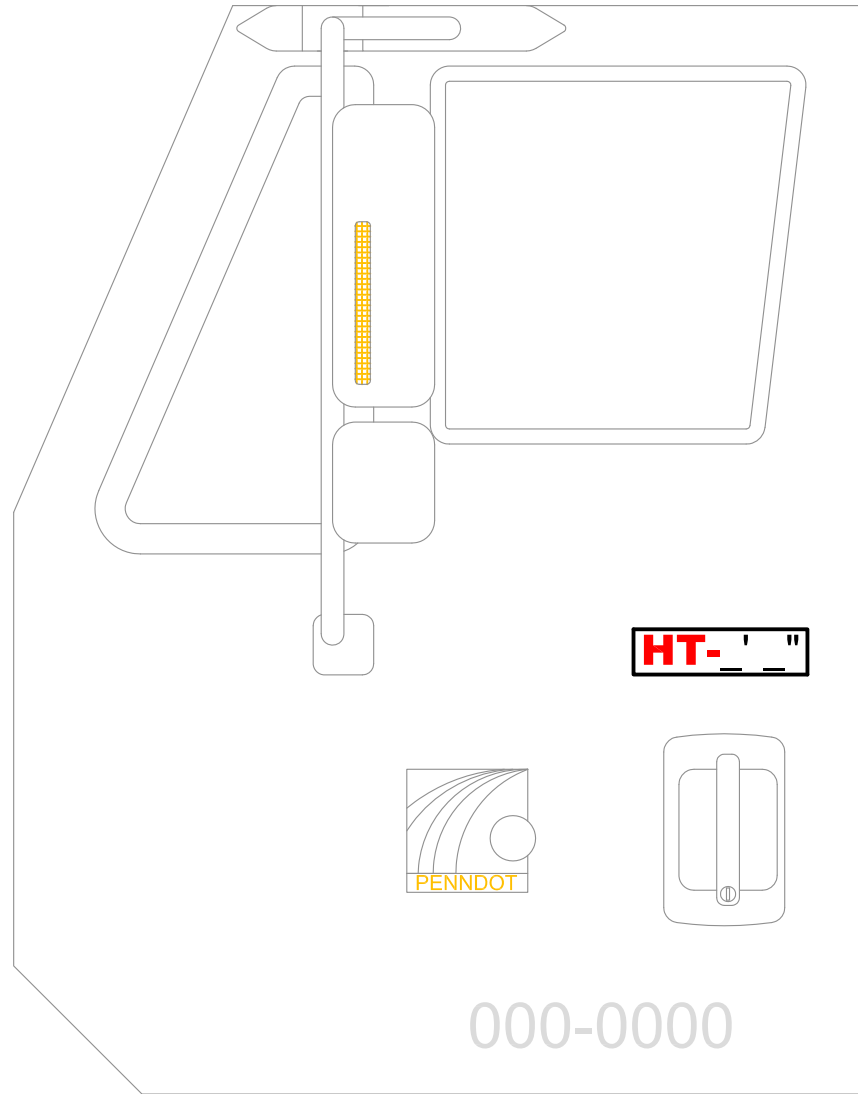

THERE SHALL BE A PERMANENT DECAL, 2 INCH HIGH RED LETTERS ON WHITE BACKGROUND AFFIXED BY THE DRIVER SIDE DOOR HANDLE STATING THE OVERALL MAXIMUM TRAVEL HEIGHT OF THE COMPLETED AND UNLOADED UNIT.

PA DEPARTMENT OF TRANSPORTATION

REVISIONS			MAX TRAVEL HEIGHT STICKER				
NO.	DATE	BY					
1	00-00-00	INT					
2			DRAWN BY	JFM	SCALE	2	EQN-552
3			DATE	05-29-13	CHK'D BY	INT	SHEET 1 OF 1



THERE SHALL BE THREE (3) PERMANENT DECALS, 4 INCH HIGH X 5 INCH WIDE, ONE EACH TO BE AFFIXED BY THE DRIVER, PASSENGER SIDE DOOR HANDLES AND THE DUMP BODY LADDER.

PA DEPARTMENT OF TRANSPORTATION				
REVISIONS			THREE POINTS OF CONTACT STICKER	
NO.	DATE	BY		
1	00-00-00	INT		
2			DRAWN BY GAW	SCALE N/A
3			DATE 03-23-15	CHK'D BY TOD
			EQN-552-1	SHEET 1 OF 1

Table of Contents

PART I - GENERAL INFORMATION 3

I.1 IFB-001.1 Purpose (Oct 2006) 3

I.2 IFB-005.1 Type of Contract (Oct. 2006)..... 3

I.3 IFB-008.1C No Pre-bid Conference (Oct. 2006) 3

I.4 IFB-009.1 Questions (February 2012)..... 3

I.5 IFB-010.1 Addenda to the IFB (Oct. 2006)..... 3

I.6 IFB-011.1B Submission of Bids – Electronic Submittal (May 2011)..... 3

I.7 IFB-024.1 Bid Protest Procedure (April 2016) 4

I.8 IFB-025.1 Electronic Version of this IFB (Oct 2006)..... 4

I.9 IFB-029.1 Prices (Dec 6 2006)..... 4

I.10 IFB-030.1 Approved Equal (Nov 2006)..... 4

I.11 IFB-031.1 Alternates (Oct 2013)..... 4

I.12 IFB-032.1 New Equipment (Nov 2006)..... 5

I.13 I-IFB-033.1 Modification or Withdrawal of Bid (Nov 2006) 5

I.14 I-IFB-034.1 Rejection of Bids (Nov 2006) 6

I.15 Submission-001.1 Representations and Authorizations (Oct 2013)..... 6

PART II - REQUIREMENTS 8

II.1 II-IFB-008.1b Lobbying Certification and Disclosure – Electronic Submission. (Oct 2006). 8

II.2 IFB-010.1 License Required (Oct 2013)..... 8

II.3 IFB-011.1 Authorized Dealer/Franchiser (Oct 2006) 8

II.4 II-IFB-016.1 Post-Submission Descriptive Literature (Dec 2006) 8

II.5 II-IFB-017.1b Reciprocal Limitations Act – Electronic Submittal (February 2007)..... 8

PART III - SELECTION CRITERIA 9

III.1 III-IFB-001.1a Mandatory Responsiveness Requirements (Oct 2006) 9

III.2 III-IFB-006.1b Method of Award - By Lot (February 2012) 9

III.3 III-IFB-007.1 Awards (May 2011) 9

III.4 III-IFB-008.1 Tie Bids (Nov 2006) 9

III.5 III-IFB-009.1 Prompt Payment Discounts (Nov 2006) 9

III.6 III-IFB-010.1 Option for Separate Competitive Bidding Procedure (Nov 2006)..... 9

III.7 III-IFB-014.1 Rebates (Nov 2006) 9

PART IV - WORK STATEMENT 11

IV.1 IFB-001.1a Specifications (Nov 2006)..... 11

PART V - CONTRACT TERMS and CONDITIONS 12

V.1 CONTRACT-001.1b Contract Terms and Conditions (Nov 30, 2006)..... 12

V.2 CONTRACT-002.1a Term of Contract – Contract (May 2012) 12

V.3 CONTRACT-002.2b Renewal of Contract Term – Mutual (Oct 2013) 12

V.4 CONTRACT-002.3 Extension of Contract Term (Nov 30 2006) 12

V.5 CONTRACT-003.1a Signatures – Contract (July 2015)..... 12

V.6 CONTRACT-004.1a Definitions (Oct 2013)..... 13

V.7 CONTRACT-005.1c Purchase Orders - Vehicles (July 2015)..... 13

V.8 CONTRACT-006.1 Independent Prime Contractor (Oct 2006)..... 14

V.9 CONTRACT-007.01c Delivery – Vehicles (Oct 2013)..... 14

V.10 CONTRACT-007.02 Estimated Quantities (Nov 30 2006)..... 14

V.11 CONTRACT-008.1a Warranty. (Oct 2006) 14

V.12 CONTRACT-009.1c Patent, Copyright, and Trademark Indemnity (Oct 2013)..... 14

V.13 CONTRACT-009.1d Ownership Rights (Oct 2006) 15

V.14 CONTRACT-010.1a Acceptance (Oct 2006)..... 15

V.15 CONTRACT-010.2 Product Conformance (March 2012) 16

V.16 CONTRACT-010.3 Rejected Material Not Considered Abandoned (March 2012) 16

V.17 CONTRACT-011.1a Compliance With Law (Oct 2006) 16

V.18 CONTRACT-013.1 Environmental Provisions (Oct 2006)..... 16

V.19 CONTRACT-014.1 Post-Consumer Recycled Content (June 2016)..... 16

V.20 CONTRACT-014.3 Recycled Content Enforcement (February 2012) 17

V.21 CONTRACT-015.1 Compensation (Oct 2006) 17

V.22 CONTRACT-015.2 Billing Requirements (February 2012) 17

V.23 CONTRACT-016.1 Payment (Oct 2006) 17

V.24 CONTRACT-016.2 ACH Payments (Aug 2007)	18
V.25 CONTRACT-017.1 Taxes (Dec 5 2006)	18
V.26 CONTRACT-018.1 Assignment of Antitrust Claims (Oct 2006)	18
V.27 CONTRACT-019.1 Hold Harmless Provision (Nov 30 2006).....	18
V.28 CONTRACT-020.1 Audit Provisions (Oct 2006)	19
V.29 CONTRACT-021.1 Default (Oct 2013)	19
V.30 CONTRACT-022.1 Force Majeure (Oct 2006).....	20
V.31 CONTRACT-023.1a Termination Provisions (Oct 2013).....	20
V.32 CONTRACT-024.1 Contract Controversies (Oct 2011)	21
V.33 CONTRACT-025.1 Assignability and Subcontracting (Oct 2013).....	21
V.34 CONTRACT-026.1 Other Contractors (Oct 2006).....	22
V.35 CONTRACT-027.1 Nondiscrimination/Sexual Harassment Clause (March 2015).....	22
V.36 CONTRACT-028.1 Contractor Integrity Provisions (January 2015).....	23
V.37 CONTRACT-029.1 Contractor Responsibility Provisions (Nov 2010)	25
V.38 CONTRACT-030.1 Americans with Disabilities Act (Oct 2006).....	26
V.39 CONTRACT-031.1 Hazardous Substances (Oct 2013)	26
V.40 CONTRACT-032.1 Covenant Against Contingent Fees (Oct 2006)	28
V.41 CONTRACT-033.1 Applicable Law (Oct 2006).....	28
V.42 CONTRACT- 034.1b Integration (Nov 30 2006).....	28
V.43 CONTRACT-034.2b Order of Precedence - IFB (Dec 6 2006)	28
V.44 CONTRACT-034.3 Controlling Terms and Conditions (Aug 2011)	28
V.45 CONTRACT-035.1a Changes (Oct 2006).....	29
V.46 CONTRACT-037.1a Confidentiality (Oct 2013)	29
V.47 CONTRACT-046.1 Manufacturer’s Price Reduction (Oct 2006).....	30
V.48 CONTRACT-047.1 Motor Vehicles to be manufactured in North America (Oct 2006)	30
V.49 CONTRACT-047.2b General Delivery Requirements for Vehicles (Oct 2012).....	30
V.50 CONTRACT-051.1 Notice (Dec 2006).....	30
V.51 CONTRACT-052.1 Right to Know Law (Feb 2010)	31

PART I - GENERAL INFORMATION

PART I - GENERAL INFORMATION

I.1 IFB-001.1 Purpose (Oct 2006)

The Commonwealth of Pennsylvania (Commonwealth) is issuing this Invitation for Bids (IFB) to meet the needs of DGS (DEPARTMENT OF GENERAL SERVICES) to satisfy a need for Highway Support Vehicles.

I.2 IFB-005.1 Type of Contract (Oct. 2006)

If the Issuing Office enters into a contract as a result of this IFB, it will be a Established Price Contract contract containing the Contract Terms and Conditions as shown in Part V of this IFB.

I.3 IFB-008.1C No Pre-bid Conference (Oct. 2006)

There will be no pre-bid conference for this IFB. If there are any questions, please forward them to the Issuing Office prior to the bid opening date and time.

I.4 IFB-009.1 Questions (February 2012)

All questions regarding the IFB must be submitted in writing to the email address of the Issuing Officer provided in the solicitation. While there is no set timeline for the submittal of questions, questions received within 48 hours prior to the bid due date and time will be answered at the discretion of the Commonwealth. All questions received will be answered, in writing, and such responses shall be posted to eMarketplace as an addendum to the IFB. The Issuing Officer shall not be bound by any verbal information nor shall it be bound by any written information that is not either contained within the IFB or formally issued as an addendum by the Issuing Office. The Issuing Office does not consider questions to be a protest of the specifications or of the solicitation.

I.5 IFB-010.1 Addenda to the IFB (Oct. 2006)

If the Issuing Office deems it necessary to revise any part of this IFB before the bid response date, the Issuing Office will post an addendum to its website at [HTTP://WWW.EMARKETPLACE.STATE.PA.US](http://WWW.EMARKETPLACE.STATE.PA.US) it is the Bidder's responsibility to periodically check the website for any new information or addenda to the IFB.

I.6 IFB-011.1B Submission of Bids – Electronic Submittal (May 2011)

- a. Bids are requested for the item(s) described in the Invitation For Bids and all the documents referenced in the form (collectively called the IFB). Bidders must submit their bids through the Commonwealth's electronic system (SRM).
- b. It is the responsibility of each bidder to ensure that its Bid is received through the electronic system prior to the date and time set for the opening of bids ("Bid Opening Time"). No Bid shall be considered if it arrives after the Bid Opening Time, regardless of reason for the late arrival.

Bids that are timely received prior to the Bid Opening Time shall be opened publicly in the presence of one or more witnesses at the time and place designated in this IFB for the Bid opening.

- c. Bids must be firm. If a Bid is submitted with conditions or exceptions or not in conformance with the terms

and conditions referenced in the IFB Form, it shall be rejected. The Bid shall also be rejected if the items offered by the Bidder are not in conformance with the specifications as determined by the Commonwealth.

d. The Bidder, intending to be legally bound hereby, offers and agrees, if this Bid is accepted, to provide the awarded items at the price(s) set forth in this Bid at the time(s) and place(s) specified.

I.7 IFB-024.1 Bid Protest Procedure (April 2016)

The Bid Protest Procedure is on the DGS website at

<http://www.dgs.pa.gov/Documents/Procurement%20Forms/Handbook/Pt1/Pt%20I%20Ch%2058%20Bid%20Protests.pdf>

I.8 IFB-025.1 Electronic Version of this IFB (Oct 2006)

This IFB is being made available by electronic means. If a Bidder electronically accepts the IFB, the Bidder acknowledges and accepts full responsibility to insure that no changes are made to the IFB. In the event of a conflict between a version of the IFB in the Bidder's possession and the Issuing Office's version of the IFB, the Issuing Office's version shall govern.

I.9 IFB-029.1 Prices (Dec 6 2006)

The bid submitted by the successful Bidder will be incorporated into any resulting Contract and the Bidder will be required to provide the awarded item(s) at the prices quoted in its Bid.

I.10 IFB-030.1 Approved Equal (Nov 2006)

Whenever an item is defined in this IFB by trade name and catalogue number of a manufacturer or vendor, the term 'or approved equal,' if not inserted therewith shall be implied. Any reference to a particular manufacturer's product either by trade name or by limited description is solely for the purpose of more clearly indicating the minimum standard of quality desired, except where a 'no substitute' is requested. When a 'no substitute' is requested, the Issuing Office will consider Bids for the referenced product only. The term 'or approved equal' is defined as meaning any other make which, in the sole opinion of the Issuing Office, is of such character, quality, and performance equivalence as to meet the standard of quality of products specified for which it is to be used equally as well as that specified. A Bidder quoting on a product other than the referenced product shall: a) furnish complete identification in its Bid of the product it is offering by trade name, brand and/or model number; b) furnish descriptive literature and data with respect to the substitute product it proposes to furnish; and c) indicate any known specification deviations from the referenced product.

I.11 IFB-031.1 Alternates (Oct 2013)

A Bidder who wants to offer an alternate must notify the Issuing Office in writing, at least five (5) days prior to the scheduled Bid opening, that the Bidder intends to offer an alternate in its Bid. An "alternate" is a product that deviates from the requirements of the specifications in its composition, qualities, performance, size dimension, etc. The written notification from the Bidder must include a complete description of the alternate and must identify the product's deviations from the specifications. Upon receipt of the notification, the Issuing Office will determine whether the alternate is acceptable. If the Issuing Office, in its discretion, determines that the alternate is acceptable, the Issuing Office will issue a change notice to the invitation for bids that revises the specifications. If no change notice is issued revising the specification, a Bid offering the alternate will not be considered for award. If an item or items in the IFB are designated "no substitute," this provision does not apply and no alternate may be proposed by a bidder nor will any alternate be considered by the Issuing Office.

I.12 IFB-032.1 New Equipment (Nov 2006)

Unless otherwise specified in this invitation for bids, all products offered by Bidders must be new or remanufactured. A 'new' product is one that will be used first by the Commonwealth after it is manufactured or produced. A 'remanufactured' product is one which: 1) has been rebuilt, using new or used parts, to a condition which meets the original manufacturer's most recent specifications for the item; 2) does not, in the opinion of the Issuing Office, differ in appearance from a new item; and 3) has the same warranty as a new item. Unless otherwise specified in this invitation for bids, used or reconditioned products are not acceptable. This clause shall not be construed to prohibit Bidders from offering products with recycled content, provided the product is new or remanufactured.

I.13 I-IFB-033.1 Modification or Withdrawal of Bid (Nov 2006)

- a. Bid Modification Prior to Bid Opening. Bids may be modified only by written notice or in person prior to the exact hour and date specified for Bid opening.
 - 1) If a Bidder intends to modify its Bid by written notice, the notice must specifically identify the Bid to be modified and must be signed by the Bidder. The Bidder must include evidence of authorization for the individual who signed the modification to modify the Bid on behalf of the Bidder. The Bid modification must be received in a sealed envelope. The sealed envelope must identify the assigned Collective Number and the Bid Opening Time, and should state that enclosed in the envelope is a Bid modification
 - 2) If a Bidder intends to modify its Bid in person, the individual who will modify the Bid must arrive in the Bid Opening Room prior to the Bid Opening Time, show a picture identification and provide evidence of his/her authorization to modify the Bid on behalf of the Bidder. If a Bidder intends to modify its Bid in person, the Bidder may do so only in the presence of an agency employee. (The agency employee will observe the actions taken by the individual to modify the Bid, but will not read the Bid or the modification).
- b. Bid Withdrawal Prior to Bid Opening. Bids may be withdrawn only by written notice or in person prior to the exact hour and date specified for Bid opening.
 - 1) If a Bidder intends to withdraw its Bid by written notice, the notice shall specifically identify the Bid to be withdrawn and shall be signed by the Bidder. The Bidder must include evidence of authorization for the individual who signed the bid withdrawal to withdraw the bid on behalf of the Bidder. Except as provided in Subparagraph c, below, bid withdrawals received after the exact hour and date specified for the receipt of Bids shall not be accepted.
 - 2) If a Bidder intends to withdraw its Bid in person, the individual who will withdraw the Bid must arrive in the Bid Opening Room prior to the Bid Opening Time, show a picture identification and provide evidence of his/her authorization to withdraw the Bid on behalf of the Bidder.
- c. Bid Withdrawal After Bid Opening. Bidders are permitted to withdraw erroneous Bids after Bid opening only if the following conditions are met:
 - 1) The Bidder submits a written request for withdrawal.
 - 2) The Bidder presents credible evidence with the request that the reason for the lower Bid price was a clerical mistake as opposed to a judgment mistake and was actually due to an unintentional arithmetical error or an unintentional omission of a substantial quantity of work, labor, material, or services made directly in the compilation of the Bid.
 - 3) The request for relief and supporting evidence must be received by the Issuing Office within three (3) business days after Bid opening, but before award of the contract.
 - 4) The Issuing Office shall not permit a Bid withdrawal if the Bid withdrawal would result in the award of the contract on another Bid of the same Bidder, its partner, or a corporation or business venture owned by or in

which the bidder has a substantial interest.

- 5) If a Bidder is permitted to withdraw its Bid, the Bidder cannot supply any material or labor or perform any subcontract or other work agreement for the awarded contractor, without the written approval of the Issuing Office.
- d. Firm Bid. Except as provided above, a Bid may not be modified, withdrawn, or cancelled by any Bidder for a period of sixty (60) days following the time and date designated for Bid opening, unless otherwise specified by the Bidder in its Bid. If the lowest responsible Bidder, as determined by the Issuing Office, withdraws its Bid prior to the expiration of the award period or fails to comply with the requirements set forth in the IFB including but not limited to any requirement to submit performance or payment bonds or insurance certificates within the required time period, the Bidder shall be liable to the Commonwealth for all costs and damages associated with the re-award or re-bid including the difference between the Bidder's price and the actual cost that the Commonwealth pays for the awarded items.
- e. Clarification and Additional Information. After the receipt of Bids, the Issuing Office shall have the right to contact Bidders for the purpose of seeking:
 - 1) Clarification of the Bid which confirms the Issuing Office's understanding of statements or information in the Bid or;
 - 2) Additional information on the items offered; provided the IFB does not require the rejection of the Bid for failure to include such information.

I.14 I-IFB-034.1 Rejection of Bids (Nov 2006)

The Issuing Office reserves the right to reject any and all Bids, to waive technical defects or any informality in Bids, and to accept or reject any part of any Bid if the best interests of the Commonwealth are thereby served.

I.15 Submission-001.1 Representations and Authorizations (Oct 2013)

By submitting its proposal, each Offeror understands, represents, and acknowledges that:

- A. All of the Offeror's information and representations in the proposal are material and important, and the Issuing Office may rely upon the contents of the proposal in awarding the contract(s). The Commonwealth shall treat any misstatement, omission or misrepresentation as fraudulent concealment of the true facts relating to the Proposal submission, punishable pursuant to 18 Pa. C.S. § 4904.
- B. The Offeror has arrived at the price(s) and amounts in its proposal independently and without consultation, communication, or agreement with any other Offeror or potential offeror.
- C. The Offeror has not disclosed the price(s), the amount of the proposal, nor the approximate price(s) or amount(s) of its proposal to any other firm or person who is an Offeror or potential offeror for this RFP, and the Offeror shall not disclose any of these items on or before the proposal submission deadline specified in the Calendar of Events of this RFP.
- D. The Offeror has not attempted, nor will it attempt, to induce any firm or person to refrain from submitting a proposal on this contract, or to submit a proposal higher than this proposal, or to submit any intentionally high or noncompetitive proposal or other form of complementary proposal.
- E. The Offeror makes its proposal in good faith and not pursuant to any agreement or discussion with, or inducement from, any firm or person to submit a complementary or other noncompetitive proposal.
- F. To the best knowledge of the person signing the proposal for the Offeror, the Offeror, its affiliates, subsidiaries, officers, directors, and employees are not currently under investigation by any governmental agency and have not in the last **four** years been convicted or found liable for any act prohibited by State or

Federal law in any jurisdiction, involving conspiracy or collusion with respect to bidding or proposing on any public contract, except as the Offeror has disclosed in its proposal.

G. To the best of the knowledge of the person signing the proposal for the Offeror and except as the Offeror has otherwise disclosed in its proposal, the Offeror has no outstanding, delinquent obligations to the Commonwealth including, but not limited to, any state tax liability not being contested on appeal or other obligation of the Offeror that is owed to the Commonwealth.

H. The Offeror is not currently under suspension or debarment by the Commonwealth, any other state or the federal government, and if the Offeror cannot so certify, then it shall submit along with its proposal a written explanation of why it cannot make such certification.

I. The Offeror has not made, under separate contract with the Issuing Office, any recommendations to the Issuing Office concerning the need for the services described in its proposal or the specifications for the services described in the proposal.

J. Each Offeror, by submitting its proposal, authorizes Commonwealth agencies to release to the Commonwealth information concerning the Offeror's Pennsylvania taxes, unemployment compensation and workers' compensation liabilities.

K. Until the selected Offeror receives a fully executed and approved written contract from the Issuing Office, there is no legal and valid contract, in law or in equity, and the Offeror shall not begin to perform.

PART II - REQUIREMENTS

PART II - REQUIREMENTS

II.1 II-IFB-008.1b Lobbying Certification and Disclosure – Electronic Submission. (Oct 2006).

With respect to an award of a federal contract, grant, or cooperative agreement exceeding \$100,000 or an award of a federal loan or a commitment providing for the United States to insure or guarantee a loan exceeding \$150,000 all recipients must certify that they will not use federal funds for lobbying and must disclose the use of non-federal funds for lobbying by filing required documentation. Offerors must complete and return the Lobbying Certification Form and the Disclosure of Lobbying Activities Form, which are attached to and made a part of this IFB. The completed and signed Lobbying Certification Form and the Disclosure of Lobbying Activities Form should be submitted with the Bid Response. Commonwealth agencies will not contract with outside firms or individuals to perform lobbying services, regardless of the source of funds.

II.2 IFB-010.1 License Required (Oct 2013)

It is unlawful for any individual, corporation, partnership, association or other entity foreign or domestic to engage in the business of salesperson, broker, dealer, manufacturer, factory branch, distributor, distributor branch, factory or distributor representative or wholesaler within COMMONWEALTH unless he has secured a license as required by Act No. 84 of 1983, known as the Board of Vehicles Act. Before a Contract is awarded to any bidder and before a bidder sells COMMONWEALTH any vehicle covered by this requisition, he must hold or secure an appropriate license issued by the State Board of Vehicle Manufacturers, Dealers and Salespersons. Information and/or an application in regard to the license requirement can be obtained from:

Department of State
Bureau of Professional and Occupational Affairs
State Board of Motor Vehicle Manufacturers, Dealers and Salesmen
P.O. Box 2649
Harrisburg, PA 17105-2649

Out-Of-State Dealers are not required to secure a license under Act No. 84 of 1983, and therefore, do not need to comply with this "License Required" Section. If you are a PA Dealer, please submit your license number with your bid.

II.3 IFB-011.1 Authorized Dealer/Franchiser (Oct 2006)

In order to be eligible for award, an offeror must be an Authorized/Franchised dealer representing the manufacturer of Vehicles offered to the Commonwealth.

II.4 II-IFB-016.1 Post-Submission Descriptive Literature (Dec 2006)

The Commonwealth may, during its evaluation of the bids, require any bidder to submit cuts, illustrations, drawings, prints, test data sheets, specification sheets and brochures which detail construction features, design, components, materials used, applicable dimensions and any other pertinent information which the Issuing Office may require in order to evaluate the product(s) offered. The required information must be submitted within two (2) business days after notification from the Issuing Office. Failure to submit the required information prior to the expiration of the second business day after notification shall result in the rejection of the bid as non-responsive.

II.5 II-IFB-017.1b Reciprocal Limitations Act – Electronic Submittal (February 2007)

This procurement is subject to the Reciprocal Limitations Act. Bidders must complete and submit with the Bid Response the State of Manufacture Chart, which is contained in GSPUR-89 ("Reciprocal Limitations Act Requirements") which is attached to and made part of this IFB. The completed State of Manufacture Chart should be submitted as part of the Bid Response.

PART III - SELECTION CRITERIA

PART III - SELECTION CRITERIA

III.1 III-IFB-001.1a Mandatory Responsiveness Requirements (Oct 2006)

To be eligible for selection, a bid must be:

- a. Timely received from a Bidder;
- b. Properly signed by the Bidder.

III.2 III-IFB-006.1b Method of Award - By Lot (February 2012)

It is the intent of the Commonwealth to award by lots established in the IFB or in the pricing spreadsheets to the lowest responsive and responsible bidder per lot. The Commonwealth reserves the right to award by line item or to award all lots to a single vendor if it determines that it is in the best interest of the Commonwealth to do so.

III.3 III-IFB-007.1 Awards (May 2011)

Unless all Bids are rejected, and except as otherwise provided by law, award will be made through the issuance of a contract/purchase order in accordance with the method of award. Unless otherwise specified by the Issuing Office in the IFB form the Commonwealth reserves the right to award by item or on a total Bid basis, whichever is deemed more advantageous to the Commonwealth. In cases of discrepancies in prices, the unit price will be binding unless the unit price is obviously in error and the extended price is obviously correct, in which case the erroneous unit price will be corrected. As a condition for receipt of award of a contract/purchase order, the Bidder must be registered in the Commonwealth of Pennsylvania's Vendor Master file. In order to register, bidders must visit the Pa Supplier Portal at <https://www.pasupplierportal.state.pa.us/> or call the Customer Support Center at 877-435-7363 or 717-346-2676.

III.4 III-IFB-008.1 Tie Bids (Nov 2006)

All tie bids will be broken by the Issuing Office.

III.5 III-IFB-009.1 Prompt Payment Discounts (Nov 2006)

Prompt payment discounts will not be considered in making an award. If prompt payment discounts are offered by any Bidder, however, the Issuing Office will take advantage of such offer.

III.6 III-IFB-010.1 Option for Separate Competitive Bidding Procedure (Nov 2006)

The Commonwealth reserves the right to purchase products or services covered under this Contract through a separate competitive bidding procedure, whenever Commonwealth deems it in the best interest of the Commonwealth. The right will generally be exercised only when a specific need for a large quantity of the product or service exists or when the price offered is significantly lower than the Contract price.

III.7 III-IFB-014.1 Rebates (Nov 2006)

Any rebate applicable at the time of bid should be taken into consideration by the bidder in calculating its bid price. Bidders must specifically state in their bid proposal, when applicable, that rebates have been considered in arriving at the bid price. Following award, the Commonwealth will assign to the awarded bidder, any rebates which the bidder stated that he took into consideration. If the bidder fails to include such a statement, the Commonwealth will

receive the full benefit of the manufacturer's rebate.

PART IV - WORK STATEMENT

PART IV - WORK STATEMENT

IV.1 IFB-001.1a Specifications (Nov 2006)

The Commonwealth is seeking bids to procure the item(s) set forth in the attached document entitled "Specifications."

PART V - CONTRACT TERMS and CONDITIONS

PART V - CONTRACT TERMS and CONDITIONS

V.1 CONTRACT-001.1b Contract Terms and Conditions (Nov 30, 2006)

The Contract with the awarded bidder (who shall become the "Contractor") shall include the following terms and conditions:

V.2 CONTRACT-002.1a Term of Contract – Contract (May 2012)

The initial term of the Contract shall be 02 year(s) and 00 month(s).

The term of the Contract shall commence on the Effective Date (as defined below) and shall end on the Expiration Date identified in the Contract, subject to the other provisions of the Contract.

The Effective Date shall be: a) the Effective Date printed on the Contract after the Contract has been fully executed by the Commonwealth (signed and approved as required by the Commonwealth contracting procedures) or b) the "Valid from" date printed on the Contract, whichever is later.

V.3 CONTRACT-002.2b Renewal of Contract Term – Mutual (Oct 2013)

The Contract may be mutually renewed for a maximum of 3 additional 1 year term(s), so long as the Commonwealth provides written notice to Contractor of its intention to extend the Contract by letter dated not less than 090 days prior to the expiration of the term of the agreement, or any extension thereof, and the Contractor consents to the renewal not less than 060 days prior to the expiration of the term of the agreement or any extension thereof. The renewal may be exercised as individual or multiple year terms(s). Any renewal will be under the same terms, covenants and conditions. No further document is required to be executed to renew the term of the contract.

V.4 CONTRACT-002.3 Extension of Contract Term (Nov 30 2006)

The Commonwealth reserves the right, upon notice to the Contractor, to extend any single term of the Contract for up to three (3) months upon the same terms and conditions.

V.5 CONTRACT-003.1a Signatures – Contract (July 2015)

The Contract shall not be a legally binding contract until the fully-executed Contract has been sent to the Contractor. No Commonwealth employee has the authority to verbally direct the commencement of any work or delivery of any supply under this Contract prior to the Effective Date. The Contractor hereby waives any claim or cause of action for any service or work performed prior to the Effective Date.

The Contract may be electronically signed by the Commonwealth. The electronically-printed name of the Purchasing Agent represents the signature of that individual who has the authority, on behalf of the Commonwealth, to bind the Commonwealth to the terms of the Contract. If the Contract output form does not have "Fully Executed" at the top of the first page and does not have the name of the Purchasing Agent printed in the appropriate box, the Contract has not been fully executed.

The fully-executed Contract may be sent to the Contractor electronically or through facsimile equipment. The electronic transmission of the Contract shall require acknowledgement of receipt of the transmission by the Contractor. Receipt of the electronic or facsimile transmission of the Contract shall constitute receipt of the fully-executed Contract.

The Commonwealth and the Contractor specifically agree as follows:

- a. No handwritten signature shall be required in order for the Contract to be legally enforceable.
- b. The parties agree that no writing shall be required in order to make the Contract legally binding, notwithstanding

contrary requirements in any law. The parties hereby agree not to contest the validity or enforceability of a genuine Contract or acknowledgement issued electronically under the provisions of a statute of frauds or any other applicable law relating to whether certain agreements be in writing and signed by the party bound thereby. Any genuine Contract or acknowledgement issued electronically, if introduced as evidence on paper in any judicial, arbitration, mediation, or administrative proceedings, will be admissible as between the parties to the same extent and under the same conditions as other business records originated and maintained in documentary form. Neither party shall contest the admissibility of copies of a genuine Contract or acknowledgements under either the business records exception to the hearsay rule or the best evidence rule on the basis that the Contract or acknowledgement were not in writing or signed by the parties. A Contract or acknowledgment shall be deemed to be genuine for all purposes if it is transmitted to the location designated for such documents.

c. Each party will immediately take steps to verify any document that appears to be obviously garbled in transmission or improperly formatted to include re-transmission of any such document if necessary.

V.6 CONTRACT-004.1a Definitions (Oct 2013)

As used in this Contract, these words shall have the following meanings:

a. Agency: The department, board, commission or other agency of the Commonwealth of Pennsylvania listed as the Purchasing Agency. If a COSTARS entity or external procurement activity has issued an order against this contract, that entity shall also be identified as "Agency".

b. Contracting Officer: The person authorized to administer this Contract for the Commonwealth and to make written determinations with respect to the Contract.

c. Days: Unless specifically indicated otherwise, days mean calendar days.

d. Developed Works or Developed Materials: All documents, sketches, drawings, designs, works, papers, files, reports, computer programs, computer documentation, data, records, software, samples or any other tangible material without limitation authored or prepared by Contractor as the work product covered in the scope of work for the Project.

e. Documentation: All materials required to support and convey information about the services required by this Contract. It includes, but is not necessarily restricted to, written reports and analyses, diagrams, maps, logical and physical designs, system designs, computer programs, flow charts, disks, and/or other machine-readable storage media.

f. Services: All Contractor activity necessary to satisfy the Contract.

V.7 CONTRACT-005.1c Purchase Orders - Vehicles (July 2015)

Commonwealth agencies may issue Purchase Orders against the Contract. These orders constitute the Contractor's authority to make delivery. All Purchase Orders received by the Contractor up to and including the expiration date of the Contract are acceptable and must be performed in accordance with the Contract. Each Purchase Order will be deemed to incorporate the terms and conditions set forth in the Contract.

Purchase Orders may be electronically signed by the Agency. The electronically-printed name of the purchaser represents the signature of that individual who has the authority, on behalf of the Commonwealth, to authorize the Contractor to proceed.

Purchase Orders may be issued electronically or through facsimile equipment. Receipt of the electronic or facsimile transmission of the Purchase Order shall constitute receipt of an order. Orders received by the Contractor after 4:00 p.m. will be considered received the following business day. The Contractor must acknowledge receipt of an order within ten (10) days from the day the purchase order is issued to the Contractor. In order to insure timely delivery, the Commonwealth should follow up on orders if written acknowledgment is not received within ten (10) days.

The Commonwealth and the Contractor specifically agree as follows:

a. No handwritten signature shall be required in order for the Contract or Purchase Order to be legally enforceable.

b. Any order which is issued electronically shall not give rise to any obligation to deliver on the part of the Contractor, or any obligation to receive and pay for delivered products on the part of the Commonwealth, unless and until the Commonwealth Agency transmitting the order has properly received an acknowledgement.

c. The parties agree that no writing shall be required in order to make the Purchase Order legally binding. The parties hereby agree not to contest the validity or enforceability of a Purchase Order or acknowledgement issued electronically under the provisions of a statute of frauds or any other applicable law relating to whether certain agreements be in writing and signed by the party bound thereby. Any Purchase Order or acknowledgement issued electronically, if introduced as evidence on paper in any judicial, arbitration, mediation, or administrative proceedings, will be admissible as between the parties to the same extent and under the same conditions as other business records originated and maintained in documentary form. Neither party shall contest the admissibility of copies of Purchase Orders or acknowledgements under either the business records exception to the hearsay rule or the best evidence rule on the basis that the Purchase Order or acknowledgement were not in writing or signed by the parties. A Purchase Order or acknowledgment shall be deemed to be genuine for all purposes if it is transmitted to the location designated for such documents.

d. Each party will immediately take steps to verify any document that appears to be obviously garbled in transmission or improperly formatted to include re-transmission of any such document if necessary.

V.8 CONTRACT-006.1 Independent Prime Contractor (Oct 2006)

In performing its obligations under the Contract, the Contractor will act as an independent contractor and not as an employee or agent of the Commonwealth. The Contractor will be responsible for all services in this Contract whether or not Contractor provides them directly. Further, the Contractor is the sole point of contact with regard to all contractual matters, including payment of any and all charges resulting from the Contract.

V.9 CONTRACT-007.01c Delivery – Vehicles (Oct 2013)

All vehicle(s) shall be delivered F.O.B. Destination. The Contractor agrees to bear the risk of loss, injury, or destruction of the vehicle(s) ordered prior to the receipt of the vehicle(s) by the Commonwealth. Such loss, injury, or destruction shall not release the Contractor from any contractual obligations. Except as otherwise provided in this contract, all vehicle(s) must be delivered within the time period specified in the Contract. Time is of the essence and, in addition to any other remedies, the Contract is subject to termination for failure to deliver as specified.

V.10 CONTRACT-007.02 Estimated Quantities (Nov 30 2006)

It shall be understood and agreed that any quantities listed in the Contract are estimated only and may be increased or decreased in accordance with the actual requirements of the Commonwealth and that the Commonwealth in accepting any bid or portion thereof, contracts only and agrees to purchase only the materials and services in such quantities as represent the actual requirements of the Commonwealth. The Commonwealth reserves the right to purchase materials and services covered under the Contract through a separate competitive procurement procedure, whenever Commonwealth deems it to be in its best interest.

V.11 CONTRACT-008.1a Warranty. (Oct 2006)

The Contractor warrants that all items furnished and all services performed by the Contractor, its agents and subcontractors shall be free and clear of any defects in workmanship or materials. Unless otherwise stated in the Contract, all items are warranted for a period of one year following delivery by the Contractor and acceptance by the Commonwealth. The Contractor shall repair, replace or otherwise correct any problem with the delivered item. When an item is replaced, it shall be replaced with an item of equivalent or superior quality without any additional cost to the Commonwealth.

V.12 CONTRACT-009.1c Patent, Copyright, and Trademark Indemnity (Oct 2013)

The Contractor warrants that it is the sole owner or author of, or has entered into a suitable legal agreement

concerning either: a) the design of any product or process provided or used in the performance of the Contract which is covered by a patent, copyright, or trademark registration or other right duly authorized by state or federal law or b) any copyrighted matter in any report, document or other material provided to the Commonwealth under the contract.

The Contractor shall defend any suit or proceeding brought against the Commonwealth on account of any alleged patent, copyright or trademark infringement in the United States of any of the products provided or used in the performance of the Contract.

This is upon condition that the Commonwealth shall provide prompt notification in writing of such suit or proceeding; full right, authorization and opportunity to conduct the defense thereof; and full information and all reasonable cooperation for the defense of same.

As principles of governmental or public law are involved, the Commonwealth may participate in or choose to conduct, in its sole discretion, the defense of any such action.

If information and assistance are furnished by the Commonwealth at the Contractor's written request, it shall be at the Contractor's expense, but the responsibility for such expense shall be only that within the Contractor's written authorization.

The Contractor shall indemnify and hold the Commonwealth harmless from all damages, costs, and expenses, including attorney's fees that the Contractor or the Commonwealth may pay or incur by reason of any infringement or violation of the rights occurring to any holder of copyright, trademark, or patent interests and rights in any products provided or used in the performance of the Contract.

If any of the products provided by the Contractor in such suit or proceeding are held to constitute infringement and the use is enjoined, the Contractor shall, at its own expense and at its option, either procure the right to continue use of such infringement products, replace them with non-infringement equal performance products or modify them so that they are no longer infringing.

If the Contractor is unable to do any of the preceding, the Contractor agrees to remove all the equipment or software which are obtained contemporaneously with the infringing product, or, at the option of the Commonwealth, only those items of equipment or software which are held to be infringing, and to pay the Commonwealth: 1) any amounts paid by the Commonwealth towards the purchase of the product, less straight line depreciation; 2) any license fee paid by the Commonwealth for the use of any software, less an amount for the period of usage; and 3) the pro rata portion of any maintenance fee representing the time remaining in any period of maintenance paid for. The obligations of the Contractor under this paragraph continue without time limit. No costs or expenses shall be incurred for the account of the Contractor without its written consent.

V.13 CONTRACT-009.1d Ownership Rights (Oct 2006)

The Commonwealth shall have unrestricted authority to reproduce, distribute, and use any submitted report, data, or material, and any software or modifications and any associated documentation that is designed or developed and delivered to the Commonwealth as part of the performance of the Contract.

V.14 CONTRACT-010.1a Acceptance (Oct 2006)

No item(s) received by the Commonwealth shall be deemed accepted until the Commonwealth has had a reasonable opportunity to inspect the item(s). Any item(s) which is discovered to be defective or fails to conform to the specifications may be rejected upon initial inspection or at any later time if the defects contained in the item(s) or the noncompliance with the specifications were not reasonably ascertainable upon the initial inspection. It shall thereupon become the duty of the Contractor to remove rejected item(s) from the premises without expense to the Commonwealth within fifteen (15) days after notification. Rejected item(s) left longer than fifteen (15) days will be regarded as abandoned, and the Commonwealth shall have the right to dispose of them as its own property and shall retain that portion of the proceeds of any sale which represents the Commonwealth's costs and expenses in regard to the storage and sale of the item(s). Upon notice of rejection, the Contractor shall immediately replace all such rejected item(s) with others conforming to the specifications and which are not defective. If the Contractor fails,

neglects or refuses to do so, the Commonwealth shall then have the right to procure a corresponding quantity of such item(s), and deduct from any monies due or that may thereafter become due to the Contractor, the difference between the price stated in the Contract and the cost thereof to the Commonwealth.

V.15 CONTRACT-010.2 Product Conformance (March 2012)

The Commonwealth reserves the right to require any and all Contractors to:

1. Provide certified data from laboratory testing performed by the Contractor, or performed by an independent laboratory, as specified by the Commonwealth.
2. Supply published manufacturer product documentation.
3. Permit a Commonwealth representative to witness testing at the Contractor's location or at an independent laboratory.
4. Complete a survey/questionnaire relating to the bid requirements and specifications.
5. Provide customer references.
6. Provide a product demonstration at a location near Harrisburg or the using agency location.

V.16 CONTRACT-010.3 Rejected Material Not Considered Abandoned (March 2012)

The Commonwealth shall have the right to not regard any rejected material as abandoned and to demand that the Contractor remove the rejected material from the premises within thirty (30) days of notification. The Contractor shall be responsible for removal of the rejected material as well as proper clean-up. If the Contractor fails or refuses to remove the rejected material as demanded by the Commonwealth, the Commonwealth may seek payment from, or set-off from any payments due to the Contractor under this or any other Contract with the Commonwealth, the costs of removal and clean-up. This is in addition to all other rights to recover costs incurred by the Commonwealth.

V.17 CONTRACT-011.1a Compliance With Law (Oct 2006)

The Contractor shall comply with all applicable federal and state laws and regulations and local ordinances in the performance of the Contract.

V.18 CONTRACT-013.1 Environmental Provisions (Oct 2006)

In the performance of the Contract, the Contractor shall minimize pollution and shall strictly comply with all applicable environmental laws and regulations, including, but not limited to: the Clean Streams Law Act of June 22, 1937 (P.L. 1987, No. 394), as amended 35 P.S. Section 691.601 et seq.; the Pennsylvania Solid Waste Management Act, Act of July 7, 1980 (P.L. 380, No. 97), as amended, 35 P.S. Section 6018.101 et seq. ; and the Dam Safety and Encroachment Act, Act of November 26, 1978 (P.L. 1375, No. 325), as amended , 32 P.S. Section 693.1.

V.19 CONTRACT-014.1 Post-Consumer Recycled Content (June 2016)

Except as specifically waived by the Department of General Services in writing, any products which are provided to the Commonwealth as a part of the performance of the Contract must meet the minimum percentage levels for total recycled content as specified by the Environmental Protection Agency in its Comprehensive Procurement Guidelines, which can be found at <https://www.epa.gov/smm/comprehensive-procurement-guideline-cpg-program> .

V.20 CONTRACT-014.3 Recycled Content Enforcement (February 2012)

The Contractor may be required, after delivery of the Contract item(s), to provide the Commonwealth with documentary evidence that the item(s) was in fact produced with the required minimum percentage of post-consumer and recovered material content.

V.21 CONTRACT-015.1 Compensation (Oct 2006)

The Contractor shall be required to furnish the awarded item(s) at the price(s) quoted in the Purchase Order. All item(s) shall be delivered within the time period(s) specified in the Purchase Order. The Contractor shall be compensated only for item(s) that are delivered and accepted by the Commonwealth.

V.22 CONTRACT-015.2 Billing Requirements (February 2012)

Unless the Contractor has been authorized by the Commonwealth for Evaluated Receipt Settlement or Vendor Self-Invoicing, the Contractor shall include in all of its invoices the following minimum information:

- Vendor name and "Remit to" address, including SAP Vendor number;
- Bank routing information, if ACH;
- SAP Purchase Order number;
- Delivery Address, including name of Commonwealth agency;
- Description of the supplies/services delivered in accordance with SAP Purchase Order (include purchase order line number if possible);
- Quantity provided;
- Unit price;
- Price extension;
- Total price; and
- Delivery date of supplies or services.

If an invoice does not contain the minimum information set forth in this paragraph, the Commonwealth may return the invoice as improper. If the Commonwealth returns an invoice as improper, the time for processing a payment will be suspended until the Commonwealth receives a correct invoice. The Contractor may not receive payment until the Commonwealth has received a correct invoice.

Contractors are required to establish separate billing accounts with each using agency and invoice them directly. Each invoice shall be itemized with adequate detail and match the line item on the Purchase Order. In no instance shall any payment be made for services to the Contractor that are not in accordance with the prices on the Purchase Order, the Contract, updated price lists or any discounts negotiated by the purchasing agency.

V.23 CONTRACT-016.1 Payment (Oct 2006)

- a. The Commonwealth shall put forth reasonable efforts to make payment by the required payment date. The required payment date is: (a) the date on which payment is due under the terms of the Contract; (b) thirty (30) days after a proper invoice actually is received at the "Bill To" address if a date on which payment is due is not specified in the Contract (a "proper" invoice is not received until the Commonwealth accepts the service as satisfactorily performed); or (c) the payment date specified on the invoice if later than the dates established by (a) and (b) above. Payment may be delayed if the payment amount on an invoice is not based upon the price(s) as stated in the Contract. If any payment is not made within fifteen (15) days after the required payment date, the Commonwealth may pay interest as determined by the Secretary of Budget in accordance with Act No. 266 of 1982 and regulations promulgated pursuant thereto. Payment should not be construed by the Contractor as acceptance of the service performed by the Contractor. The Commonwealth reserves the right to conduct further testing and inspection after payment, but within a reasonable time after performance, and to reject the service if such post payment testing or inspection discloses a defect or a failure to meet specifications. The Contractor agrees that the Commonwealth may set off the amount of any state tax liability or other obligation of the

Contractor or its subsidiaries to the Commonwealth against any payments due the Contractor under any contract with the Commonwealth.

- b. The Commonwealth shall have the option of using the Commonwealth purchasing card to make purchases under the Contract or Purchase Order. The Commonwealth's purchasing card is similar to a credit card in that there will be a small fee which the Contractor will be required to pay and the Contractor will receive payment directly from the card issuer rather than the Commonwealth. Any and all fees related to this type of payment are the responsibility of the Contractor. In no case will the Commonwealth allow increases in prices to offset credit card fees paid by the Contractor or any other charges incurred by the Contractor, unless specifically stated in the terms of the Contract or Purchase Order.

V.24 CONTRACT-016.2 ACH Payments (Aug 2007)

- a. The Commonwealth will make contract payments through the Automated Clearing House (ACH). Within 10 days of award of the contract or purchase order, the contractor must submit or must have already submitted their ACH information within their user profile in the Commonwealth's procurement system (SRM).
- b. The contractor must submit a unique invoice number with each invoice submitted. The unique invoice number will be listed on the Commonwealth of Pennsylvania's ACH remittance advice to enable the contractor to properly apply the state agency's payment to the invoice submitted.
- c. It is the responsibility of the contractor to ensure that the ACH information contained in SRM is accurate and complete. Failure to maintain accurate and complete information may result in delays in payments.

V.25 CONTRACT-017.1 Taxes (Dec 5 2006)

The Commonwealth is exempt from all excise taxes imposed by the Internal Revenue Service and has accordingly registered with the Internal Revenue Service to make tax free purchases under Registration No. 23-23740001-K. With the exception of purchases of the following items, no exemption certificates are required and none will be issued: undyed diesel fuel, tires, trucks, gas guzzler emergency vehicles, and sports fishing equipment. The Commonwealth is also exempt from Pennsylvania state sales tax, local sales tax, public transportation assistance taxes and fees and vehicle rental tax. The Department of Revenue regulations provide that exemption certificates are not required for sales made to governmental entities and none will be issued. Nothing in this paragraph is meant to exempt a construction contractor from the payment of any of these taxes or fees which are required to be paid with respect to the purchase, use, rental, or lease of tangible personal property or taxable services used or transferred in connection with the performance of a construction contract.

V.26 CONTRACT-018.1 Assignment of Antitrust Claims (Oct 2006)

The Contractor and the Commonwealth recognize that in actual economic practice, overcharges by the Contractor's suppliers resulting from violations of state or federal antitrust laws are in fact borne by the Commonwealth. As part of the consideration for the award of the Contract, and intending to be legally bound, the Contractor assigns to the Commonwealth all right, title and interest in and to any claims the Contractor now has, or may acquire, under state or federal antitrust laws relating to the products and services which are the subject of this Contract.

V.27 CONTRACT-019.1 Hold Harmless Provision (Nov 30 2006)

- a. The Contractor shall hold the Commonwealth harmless from and indemnify the Commonwealth against any and all third party claims, demands and actions based upon or arising out of any activities performed by the Contractor and its employees and agents under this Contract, provided the Commonwealth gives Contractor prompt notice of any such claim of which it learns. Pursuant to the Commonwealth Attorneys Act (71 P.S. Section 732-101, et seq.), the Office of Attorney General (OAG) has the sole authority to represent the Commonwealth in actions brought against the Commonwealth. The OAG may, however, in its sole discretion and under such terms as it deems appropriate, delegate its right of defense. If OAG delegates the defense to the

Contractor, the Commonwealth will cooperate with all reasonable requests of Contractor made in the defense of such suits.

- b. Notwithstanding the above, neither party shall enter into any settlement without the other party's written consent, which shall not be unreasonably withheld. The Commonwealth may, in its sole discretion, allow the Contractor to control the defense and any related settlement negotiations.

V.28 CONTRACT-020.1 Audit Provisions (Oct 2006)

The Commonwealth shall have the right, at reasonable times and at a site designated by the Commonwealth, to audit the books, documents and records of the Contractor to the extent that the books, documents and records relate to costs or pricing data for the Contract. The Contractor agrees to maintain records which will support the prices charged and costs incurred for the Contract. The Contractor shall preserve books, documents, and records that relate to costs or pricing data for the Contract for a period of three (3) years from date of final payment. The Contractor shall give full and free access to all records to the Commonwealth and/or their authorized representatives.

V.29 CONTRACT-021.1 Default (Oct 2013)

a. The Commonwealth may, subject to the Force Majeure provisions of this Contract, and in addition to its other rights under the Contract, declare the Contractor in default by written notice thereof to the Contractor, and terminate (as provided in the Termination Provisions of this Contract) the whole or any part of this Contract or any Purchase Order for any of the following reasons:

- 1) Failure to begin work within the time specified in the Contract or Purchase Order or as otherwise specified;
- 2) Failure to perform the work with sufficient labor, equipment, or material to ensure the completion of the specified work in accordance with the Contract or Purchase Order terms;
- 3) Unsatisfactory performance of the work;
- 4) Failure to deliver the awarded item(s) within the time specified in the Contract or Purchase Order or as otherwise specified;
- 5) Improper delivery;
- 6) Failure to provide an item(s) which is in conformance with the specifications referenced in the Contract or Purchase Order;
- 7) Delivery of a defective item;
- 8) Failure or refusal to remove material, or remove and replace any work rejected as defective or unsatisfactory;
- 9) Discontinuance of work without approval;
- 10) Failure to resume work, which has been discontinued, within a reasonable time after notice to do so;
- 11) Insolvency or bankruptcy;
- 12) Assignment made for the benefit of creditors;
- 13) Failure or refusal within 10 days after written notice by the Contracting Officer, to make payment or show cause why payment should not be made, of any amounts due for materials furnished, labor supplied or performed, for equipment rentals, or for utility services rendered;
- 14) Failure to protect, to repair, or to make good any damage or injury to property;

- 15) Breach of any provision of the Contract;
- 16) Failure to comply with representations made in the Contractor's bid/proposal; or
- 17) Failure to comply with applicable industry standards, customs, and practice.

b. In the event that the Commonwealth terminates this Contract or any Purchase Order in whole or in part as provided in Subparagraph a. above, the Commonwealth may procure, upon such terms and in such manner as it determines, items similar or identical to those so terminated, and the Contractor shall be liable to the Commonwealth for any reasonable excess costs for such similar or identical items included within the terminated part of the Contract or Purchase Order.

c. If the Contract or a Purchase Order is terminated as provided in Subparagraph a. above, the Commonwealth, in addition to any other rights provided in this paragraph, may require the Contractor to transfer title and deliver immediately to the Commonwealth in the manner and to the extent directed by the Contracting Officer, such partially completed items, including, where applicable, reports, working papers and other documentation, as the Contractor has specifically produced or specifically acquired for the performance of such part of the Contract or Purchase Order as has been terminated. Except as provided below, payment for completed work accepted by the Commonwealth shall be at the Contract price. Except as provided below, payment for partially completed items including, where applicable, reports and working papers, delivered to and accepted by the Commonwealth shall be in an amount agreed upon by the Contractor and Contracting Officer. The Commonwealth may withhold from amounts otherwise due the Contractor for such completed or partially completed works, such sum as the Contracting Officer determines to be necessary to protect the Commonwealth against loss.

d. The rights and remedies of the Commonwealth provided in this paragraph shall not be exclusive and are in addition to any other rights and remedies provided by law or under this Contract.

e. The Commonwealth's failure to exercise any rights or remedies provided in this paragraph shall not be construed to be a waiver by the Commonwealth of its rights and remedies in regard to the event of default or any succeeding event of default.

f. Following exhaustion of the Contractor's administrative remedies as set forth in the Contract Controversies Provision of the Contract, the Contractor's exclusive remedy shall be to seek damages in the Board of Claims.

V.30 CONTRACT-022.1 Force Majeure (Oct 2006)

Neither party will incur any liability to the other if its performance of any obligation under this Contract is prevented or delayed by causes beyond its control and without the fault or negligence of either party. Causes beyond a party's control may include, but aren't limited to, acts of God or war, changes in controlling law, regulations, orders or the requirements of any governmental entity, severe weather conditions, civil disorders, natural disasters, fire, epidemics and quarantines, general strikes throughout the trade, and freight embargoes.

The Contractor shall notify the Commonwealth orally within five (5) days and in writing within ten (10) days of the date on which the Contractor becomes aware, or should have reasonably become aware, that such cause would prevent or delay its performance. Such notification shall (i) describe fully such cause(s) and its effect on performance, (ii) state whether performance under the contract is prevented or delayed and (iii) if performance is delayed, state a reasonable estimate of the duration of the delay. The Contractor shall have the burden of proving that such cause(s) delayed or prevented its performance despite its diligent efforts to perform and shall produce such supporting documentation as the Commonwealth may reasonably request. After receipt of such notification, the Commonwealth may elect to cancel the Contract, cancel the Purchase Order, or to extend the time for performance as reasonably necessary to compensate for the Contractor's delay.

In the event of a declared emergency by competent governmental authorities, the Commonwealth by notice to the Contractor, may suspend all or a portion of the Contract or Purchase Order.

V.31 CONTRACT-023.1a Termination Provisions (Oct 2013)

The Commonwealth has the right to terminate this Contract or any Purchase Order for any of the following reasons. Termination shall be effective upon written notice to the Contractor.

a. **TERMINATION FOR CONVENIENCE:** The Commonwealth shall have the right to terminate the Contract or a Purchase Order for its convenience if the Commonwealth determines termination to be in its best interest. The Contractor shall be paid for work satisfactorily completed prior to the effective date of the termination, but in no event shall the Contractor be entitled to recover loss of profits.

b. **NON-APPROPRIATION:** The Commonwealth's obligation to make payments during any Commonwealth fiscal year succeeding the current fiscal year shall be subject to availability and appropriation of funds. When funds (state and/or federal) are not appropriated or otherwise made available to support continuation of performance in a subsequent fiscal year period, the Commonwealth shall have the right to terminate the Contract or a Purchase Order. The Contractor shall be reimbursed for the reasonable value of any nonrecurring costs incurred but not amortized in the price of the supplies or services delivered under the Contract. Such reimbursement shall not include loss of profit, loss of use of money, or administrative or overhead costs. The reimbursement amount may be paid from any appropriations available for that purpose.

c. **TERMINATION FOR CAUSE:** The Commonwealth shall have the right to terminate the Contract or a Purchase Order for Contractor default under the Default Clause upon written notice to the Contractor. The Commonwealth shall also have the right, upon written notice to the Contractor, to terminate the Contract or a Purchase Order for other cause as specified in the Contract or by law. If it is later determined that the Commonwealth erred in terminating the Contract or a Purchase Order for cause, then, at the Commonwealth's discretion, the Contract or Purchase Order shall be deemed to have been terminated for convenience under the Subparagraph a.

V.32 CONTRACT-024.1 Contract Controversies (Oct 2011)

a. In the event of a controversy or claim arising from the Contract, the Contractor must, within six months after the cause of action accrues, file a written claim with the contracting officer for a determination. The claim shall state all grounds upon which the Contractor asserts a controversy exists. If the Contractor fails to file a claim or files an untimely claim, the Contractor is deemed to have waived its right to assert a claim in any forum. At the time the claim is filed, or within sixty (60) days thereafter, either party may request mediation through the Commonwealth Office of General Counsel Dispute Resolution Program.

b. If the Contractor or the contracting officer requests mediation and the other party agrees, the contracting officer shall promptly make arrangements for mediation. Mediation shall be scheduled so as to not delay the issuance of the final determination beyond the required 120 days after receipt of the claim if mediation is unsuccessful. If mediation is not agreed to or if resolution is not reached through mediation, the contracting officer shall review timely-filed claims and issue a final determination, in writing, regarding the claim. The final determination shall be issued within 120 days of the receipt of the claim, unless extended by consent of the contracting officer and the Contractor. The contracting officer shall send his/her written determination to the Contractor. If the contracting officer fails to issue a final determination within the 120 days (unless extended by consent of the parties), the claim shall be deemed denied. The contracting officer's determination shall be the final order of the purchasing agency.

c. Within fifteen (15) days of the mailing date of the determination denying a claim or within 135 days of filing a claim if, no extension is agreed to by the parties, whichever occurs first, the Contractor may file a statement of claim with the Commonwealth Board of Claims. Pending a final judicial resolution of a controversy or claim, the Contractor shall proceed diligently with the performance of the Contract in a manner consistent with the determination of the contracting officer and the Commonwealth shall compensate the Contractor pursuant to the terms of the Contract.

V.33 CONTRACT-025.1 Assignability and Subcontracting (Oct 2013)

a. Subject to the terms and conditions of this paragraph, this Contract shall be binding upon the parties and their respective successors and assigns.

b. The Contractor shall not subcontract with any person or entity to perform all or any part of the work to be performed under this Contract without the prior written consent of the Contracting Officer, which consent may be withheld at the sole and absolute discretion of the Contracting Officer.

c. The Contractor may not assign, in whole or in part, this Contract or its rights, duties, obligations, or responsibilities hereunder without the prior written consent of the Contracting Officer, which consent may be withheld at the sole and absolute discretion of the Contracting Officer.

d. Notwithstanding the foregoing, the Contractor may, without the consent of the Contracting Officer, assign its rights to payment to be received under the Contract, provided that the Contractor provides written notice of such assignment to the Contracting Officer together with a written acknowledgement from the assignee that any such payments are subject to all of the terms and conditions of this Contract.

e. For the purposes of this Contract, the term "assign" shall include, but shall not be limited to, the sale, gift, assignment, pledge, or other transfer of any ownership interest in the Contractor provided, however, that the term shall not apply to the sale or other transfer of stock of a publicly traded company.

f. Any assignment consented to by the Contracting Officer shall be evidenced by a written assignment agreement executed by the Contractor and its assignee in which the assignee agrees to be legally bound by all of the terms and conditions of the Contract and to assume the duties, obligations, and responsibilities being assigned.

g. A change of name by the Contractor, following which the Contractor's federal identification number remains unchanged, shall not be considered to be an assignment hereunder. The Contractor shall give the Contracting Officer written notice of any such change of name.

V.34 CONTRACT-026.1 Other Contractors (Oct 2006)

The Commonwealth may undertake or award other contracts for additional or related work, and the Contractor shall fully cooperate with other contractors and Commonwealth employees, and coordinate its work with such additional work as may be required. The Contractor shall not commit or permit any act that will interfere with the performance of work by any other contractor or by Commonwealth employees. This paragraph shall be included in the Contracts of all contractors with which this Contractor will be required to cooperate. The Commonwealth shall equitably enforce this paragraph as to all contractors to prevent the imposition of unreasonable burdens on any contractor.

V.35 CONTRACT-027.1 Nondiscrimination/Sexual Harassment Clause (March 2015)

The Contractor agrees:

1. In the hiring of any employee(s) for the manufacture of supplies, performance of work, or any other activity required under the contract or any subcontract, the Contractor, each subcontractor, or any person acting on behalf of the Contractor or subcontractor shall not discriminate in violation of the *Pennsylvania Human Relations Act* (PHRA) and applicable federal laws against any citizen of this Commonwealth who is qualified and available to perform the work to which the employment relates.

2. Neither the Contractor nor any subcontractor nor any person on their behalf shall in any manner discriminate in violation of the PHRA and applicable federal laws against or intimidate any employee involved in the manufacture of supplies, the performance of work, or any other activity required under the contract.

3. The Contractor and each subcontractor shall establish and maintain a written nondiscrimination and sexual harassment policy and shall inform their employees of the policy. The policy must contain a provision that sexual harassment will not be tolerated and employees who practice it will be disciplined. Posting this Nondiscrimination/Sexual Harassment Clause conspicuously in easily-accessible and well-lighted places customarily frequented by employees and at or near where the contract services are performed shall satisfy this requirement.

4. The Contractor and each subcontractor shall not discriminate in violation of PHRA and applicable federal laws against any subcontractor or supplier who is qualified to perform the work to which the contract relates.

5. The Contractor and each subcontractor represents that it is presently in compliance with and will maintain compliance with all applicable federal, state, and local laws and regulations relating to nondiscrimination and sexual harassment. The Contractor and each subcontractor further represents that it has filed a Standard Form 100 Employer Information Report ("EEO-1") with the U.S. Equal Employment Opportunity Commission ("EEOC") and shall file an annual EEO-1 report with the EEOC as required for employers subject to *Title VII of the Civil Rights Act of 1964*, as amended, that have 100 or more employees and employers that have federal government contracts or first-tier subcontracts and have 50 or more employees. The Contractor and each subcontractor shall, upon request and within the time periods requested by the Commonwealth, furnish all necessary employment documents and records, including EEO-1 reports, and permit access to their books, records, and accounts by the contracting agency and the Bureau of Small Business Opportunities (BSBO), for purpose of ascertaining compliance with provisions of this Nondiscrimination/Sexual Harassment Clause.

6. The Contractor shall include the provisions of this Nondiscrimination/Sexual Harassment Clause in every subcontract so that those provisions applicable to subcontractors will be binding upon each subcontractor.

7. The Contractor's and each subcontractor's obligations pursuant to these provisions are ongoing from and after the effective date of the contract through the termination date thereof. Accordingly, the Contractor and each subcontractor shall have an obligation to inform the Commonwealth if, at any time during the term of the contract, it becomes aware of any actions or occurrences that would result in violation of these provisions.

8. The Commonwealth may cancel or terminate the contract and all money due or to become due under the contract may be forfeited for a violation of the terms and conditions of this Nondiscrimination/Sexual Harassment Clause. In addition, the agency may proceed with debarment or suspension and may place the Contractor in the Contractor Responsibility File.

V.36 CONTRACT-028.1 Contractor Integrity Provisions (January 2015)

It is essential that those who seek to contract with the Commonwealth of Pennsylvania ("Commonwealth") observe high standards of honesty and integrity. They must conduct themselves in a manner that fosters public confidence in the integrity of the Commonwealth contracting and procurement process.

1. DEFINITIONS. For purposes of these Contractor Integrity Provisions, the following terms shall have the meanings found in this Section:

a. "Affiliate" means two or more entities where (a) a parent entity owns more than fifty percent of the voting stock of each of the entities; or (b) a common shareholder or group of shareholders owns more than fifty percent of the voting stock of each of the entities; or (c) the entities have a common proprietor or general partner.

b. "Consent" means written permission signed by a duly authorized officer or employee of the Commonwealth, provided that where the material facts have been disclosed, in writing, by prequalification, bid, proposal, or contractual terms, the Commonwealth shall be deemed to have consented by virtue of the execution of this contract.

c. "Contractor" means the individual or entity, that has entered into this contract with the Commonwealth.

d. "Contractor Related Parties" means any affiliates of the Contractor and the Contractor's executive officers, Pennsylvania officers and directors, or owners of 5 percent or more interest in the Contractor.

e. "Financial Interest" means either:

(1) Ownership of more than a five percent interest in any business; or

(2) Holding a position as an officer, director, trustee, partner, employee, or holding any position of management.

f. "Gratuity" means tendering, giving, or providing anything of more than nominal monetary value including, but

not limited to, cash, travel, entertainment, gifts, meals, lodging, loans, subscriptions, advances, deposits of money, services, employment, or contracts of any kind. The exceptions set forth in the *Governor's Code of Conduct, Executive Order 1980-18, the 4 Pa. Code §7.153(b)*, shall apply.

g. "Non-bid Basis" means a contract awarded or executed by the Commonwealth with Contractor without seeking bids or proposals from any other potential bidder or offeror.

2. In furtherance of this policy, Contractor agrees to the following:

a. Contractor shall maintain the highest standards of honesty and integrity during the performance of this contract and shall take no action in violation of state or federal laws or regulations or any other applicable laws or regulations, or other requirements applicable to Contractor or that govern contracting or procurement with the Commonwealth.

b. Contractor shall establish and implement a written business integrity policy, which includes, at a minimum, the requirements of these provisions as they relate to the Contractor activity with the Commonwealth and Commonwealth employees and which is made known to all Contractor employees. Posting these Contractor Integrity Provisions conspicuously in easily-accessible and well-lighted places customarily frequented by employees and at or near where the contract services are performed shall satisfy this requirement.

c. Contractor, its affiliates, agents, employees and anyone in privity with Contractor shall not accept, agree to give, offer, confer or agree to confer or promise to confer, directly or indirectly, any gratuity or pecuniary benefit to any person, or to influence or attempt to influence any person in violation of any federal or state law, regulation, executive order of the Governor of Pennsylvania, statement of policy, management directive or any other published standard of the Commonwealth in connection with performance of work under this contract, except as provided in this contract.

d. Contractor shall not have a financial interest in any other contractor, subcontractor, or supplier providing services, labor or material under this contract, unless the financial interest is disclosed to the Commonwealth in writing and the Commonwealth consents to Contractor's financial interest prior to Commonwealth execution of the contract. Contractor shall disclose the financial interest to the Commonwealth at the time of bid or proposal submission, or if no bids or proposals are solicited, no later than the Contractor's submission of the contract signed by Contractor.

e. Contractor certifies to the best of its knowledge and belief that within the last five (5) years Contractor or Contractor Related Parties have not:

(1) been indicted or convicted of a crime involving moral turpitude or business honesty or integrity in any jurisdiction;

(2) been suspended, debarred or otherwise disqualified from entering into any contract with any governmental agency;

(3) had any business license or professional license suspended or revoked;

(4) had any sanction or finding of fact imposed as a result of a judicial or administrative proceeding related to fraud, extortion, bribery, bid rigging, embezzlement, misrepresentation or anti-trust; and

(5) been, and is not currently, the subject of a criminal investigation by any federal, state or local prosecuting or investigative agency and/or civil anti-trust investigation by any federal, state or local prosecuting or investigative agency.

If Contractor cannot so certify to the above, then it must submit along with its bid, proposal or contract a written explanation of why such certification cannot be made and the Commonwealth will determine whether a contract may be entered into with the Contractor. The Contractor's obligation pursuant to this certification is ongoing from and after the effective date of the contract through the termination date thereof. Accordingly, the Contractor shall have an obligation to immediately notify the Commonwealth in writing if at any time during the term of the contract it becomes aware of any event which would cause the Contractor's certification or explanation to change.

Contractor acknowledges that the Commonwealth may, in its sole discretion, terminate the contract for cause if it learns that any of the certifications made herein are currently false due to intervening factual circumstances or were false or should have been known to be false when entering into the contract.

f. Contractor shall comply with the requirements of the *Lobbying Disclosure Act (65 Pa.C.S. §13A01 et seq.)* regardless of the method of award. If this contract was awarded on a Non-bid Basis, Contractor must also comply with the requirements of the *Section 1641 of the Pennsylvania Election Code (25 P.S. §3260a)*.

g. When contractor has reason to believe that any breach of ethical standards as set forth in law, the Governor's Code of Conduct, or these Contractor Integrity Provisions has occurred or may occur, including but not limited to contact by a Commonwealth officer or employee which, if acted upon, would violate such ethical standards, Contractor shall immediately notify the Commonwealth contracting officer or the Office of the State Inspector General in writing.

h. Contractor, by submission of its bid or proposal and/or execution of this contract and by the submission of any bills, invoices or requests for payment pursuant to the contract, certifies and represents that is has not violated any of these Contractor Integrity Provisions in connection with the submission of the bid or proposal, during any contract negotiations or during the term of the contract, to include any extensions thereof. Contractor shall immediately notify the Commonwealth in writing of any actions for occurrences that would result in a violation of these Contractor Integrity Provisions. Contractor agrees to reimburse the Commonwealth for the reasonable costs of investigation incurred by the Office of the State Inspector General for investigations of the Contractor's compliance with the terms of this or any other agreement between the Contractor and the Commonwealth that results in the suspension or debarment of the Contractor. Contractor shall not be responsible for investigative costs for investigations that do not result in the Contractor's suspension or debarment.

i. Contractor shall cooperate with the Office of the State Inspector General in its investigation of any alleged Commonwealth agency or employee breach of ethical standards and any alleged Contractor non-compliance with these Contractor Integrity Provisions. Contractor agrees to make identified Contractor employees available for interviews at reasonable times and places. Contractor, upon the inquiry or request of an Inspector General, shall provide, or if appropriate, make promptly available for inspection or copying, any information of any type or form deemed relevant by the Office of the State Inspector General to Contractor's integrity and compliance with these provisions. Such information may include, but shall not be limited to, Contractor's business or financial records, documents or files of any type or form that refer to or concern this contract. Contractor shall incorporate this paragraph in any agreement, contract or subcontract it enters into in the course of the performance of this contract/agreement solely for the purpose of obtaining subcontractor compliance with this provision. The incorporation of this provision in a subcontract shall not create privity of contract between the Commonwealth and any such subcontractor, and no third party beneficiaries shall be created thereby.

j. For violation of any of these Contractor Integrity Provisions, the Commonwealth may terminate this and any other contract with Contractor, claim liquidated damages in an amount equal to the value of anything received in breach of these Provisions, claim damages for all additional costs and expenses incurred in obtaining another contractor to complete performance under this contract, and debar and suspend Contractor from doing business with the Commonwealth. These rights and remedies are cumulative, and the use or non-use of any one shall not preclude the use of all or any other. These rights and remedies are in addition to those the Commonwealth may have under law, statute, regulation or otherwise.

V.37 CONTRACT-029.1 Contractor Responsibility Provisions (Nov 2010)

For the purpose of these provisions, the term contractor is defined as any person, including, but not limited to, a bidder, offeror, loan recipient, grantee or lessor, who has furnished or performed or seeks to furnish or perform, goods, supplies, services, leased space, construction or other activity, under a contract, grant, lease, purchase order or reimbursement agreement with the Commonwealth of Pennsylvania (Commonwealth). The term contractor includes a permittee, licensee, or any agency, political subdivision, instrumentality, public authority, or other public entity in the Commonwealth.

1. The Contractor certifies, in writing, for itself and its subcontractors required to be disclosed or approved by the Commonwealth, that as of the date of its execution of this Bid/Contract, that neither the Contractor, nor any such subcontractors, are under suspension or debarment by the Commonwealth or any governmental entity, instrumentality, or authority and, if the Contractor cannot so certify, then it agrees to submit, along with its Bid/Contract, a written explanation of why such certification cannot be made.
2. The Contractor also certifies, in writing, that as of the date of its execution of this Bid/Contract it has no tax liabilities or other Commonwealth obligations, or has filed a timely administrative or judicial appeal if such liabilities or obligations exist, or is subject to a duly approved deferred payment plan if such liabilities exist.
3. The Contractor's obligations pursuant to these provisions are ongoing from and after the effective date of the Contract through the termination date thereof. Accordingly, the Contractor shall have an obligation to inform the Commonwealth if, at any time during the term of the Contract, it becomes delinquent in the payment of taxes, or other Commonwealth obligations, or if it or, to the best knowledge of the Contractor, any of its subcontractors are suspended or debarred by the Commonwealth, the federal government, or any other state or governmental entity. Such notification shall be made within 15 days of the date of suspension or debarment.
4. The failure of the Contractor to notify the Commonwealth of its suspension or debarment by the Commonwealth, any other state, or the federal government shall constitute an event of default of the Contract with the Commonwealth.
5. The Contractor agrees to reimburse the Commonwealth for the reasonable costs of investigation incurred by the Office of State Inspector General for investigations of the Contractor's compliance with the terms of this or any other agreement between the Contractor and the Commonwealth that results in the suspension or debarment of the contractor. Such costs shall include, but shall not be limited to, salaries of investigators, including overtime; travel and lodging expenses; and expert witness and documentary fees. The Contractor shall not be responsible for investigative costs for investigations that do not result in the Contractor's suspension or debarment.
6. The Contractor may obtain a current list of suspended and debarred Commonwealth contractors by either searching the Internet at <http://www.dgs.state.pa.us/> or contacting the:

Department of General Services
Office of Chief Counsel
603 North Office Building
Harrisburg, PA 17125
Telephone No: (717) 783-6472
FAX No: (717) 787-9138

V.38 CONTRACT-030.1 Americans with Disabilities Act (Oct 2006)

- a. Pursuant to federal regulations promulgated under the authority of The Americans With Disabilities Act, 28 C.F.R. Section 35.101 et seq., the Contractor understands and agrees that it shall not cause any individual with a disability to be excluded from participation in this Contract or from activities provided for under this Contract on the basis of the disability. As a condition of accepting this contract, the Contractor agrees to comply with the "General Prohibitions Against Discrimination," 28 C.F.R. Section 35.130, and all other regulations promulgated under Title II of The Americans With Disabilities Act which are applicable to all benefits, services, programs, and activities provided by the Commonwealth of Pennsylvania through contracts with outside contractors.
- b. The Contractor shall be responsible for and agrees to indemnify and hold harmless the Commonwealth of Pennsylvania from all losses, damages, expenses, claims, demands, suits, and actions brought by any party against the Commonwealth of Pennsylvania as a result of the Contractor's failure to comply with the provisions of Subparagraph a. above.

V.39 CONTRACT-031.1 Hazardous Substances (Oct 2013)

The Contractor shall provide information to the Commonwealth about the identity and hazards of hazardous substances supplied or used by the Contractor in the performance of the Contract. The Contractor must comply with

Act 159 of October 5, 1984, known as the "Worker and Community Right to Know Act" (the "Act") and the regulations promulgated pursuant thereto at 4 Pa. Code Section 301.1 et seq.

a. Labeling. The Contractor shall ensure that each individual product (as well as the carton, container or package in which the product is shipped) of any of the following substances (as defined by the Act and the regulations) supplied by the Contractor is clearly labeled, tagged or marked with the information listed in Subparagraphs (1) through (4):

1) Hazardous substances:

- a) The chemical name or common name,
- b) A hazard warning, and
- c) The name, address, and telephone number of the manufacturer.

2) Hazardous mixtures:

- a) The common name, but if none exists, then the trade name,
- b) The chemical or common name of special hazardous substances comprising .01% or more of the mixture,
- c) The chemical or common name of hazardous substances consisting 1.0% or more of the mixture,
- d) A hazard warning, and
- e) The name, address, and telephone number of the manufacturer.

3) Single chemicals:

- a) The chemical name or the common name,
- b) A hazard warning, if appropriate, and
- c) The name, address, and telephone number of the manufacturer.

4) Chemical Mixtures:

- a) The common name, but if none exists, then the trade name,
- b) A hazard warning, if appropriate,
- c) The name, address, and telephone number of the manufacturer, and
- d) The chemical name or common name of either the top five substances by volume or those substances consisting of 5.0% or more of the mixture.

A common name or trade name may be used only if the use of the name more easily or readily identifies the true nature of the hazardous substance, hazardous mixture, single chemical, or mixture involved.

Container labels shall provide a warning as to the specific nature of the hazard arising from the substance in the container.

The hazard warning shall be given in conformity with one of the nationally recognized and accepted systems of providing warnings, and hazard warnings shall be consistent with one or more of the recognized systems throughout the workplace. Examples are:

- NFPA 704, Identification of the Fire Hazards of Materials.
- National Paint and Coatings Association: Hazardous Materials Identification System.
- American Society for Testing and Materials, Safety Alert Pictorial Chart.

· American National Standard Institute, Inc., for the Precautionary Labeling of Hazardous Industrial Chemicals.

Labels must be legible and prominently affixed to and displayed on the product and the carton, container, or package so that employees can easily identify the substance or mixture present therein.

b. Material Safety Data Sheet. The contractor shall provide Material Safety Data Sheets (MSDS) with the information required by the Act and the regulations for each hazardous substance or hazardous mixture. The Commonwealth must be provided an appropriate MSDS with the initial shipment and with the first shipment after an MSDS is updated or product changed. For any other chemical, the contractor shall provide an appropriate MSDS, if the manufacturer, importer, or supplier produces or possesses the MSDS. The contractor shall also notify the Commonwealth when a substance or mixture is subject to the provisions of the Act. Material Safety Data Sheets may be attached to the carton, container, or package mailed to the Commonwealth at the time of shipment.

V.40 CONTRACT-032.1 Covenant Against Contingent Fees (Oct 2006)

The Contractor warrants that no person or selling agency has been employed or retained to solicit or secure the Contract upon an agreement or understanding for a commission, percentage, brokerage, or contingent fee, except bona fide employees or bona fide established commercial or selling agencies maintained by the Contractor for the purpose of securing business. For breach or violation of this warranty, the Commonwealth shall have the right to terminate the Contract without liability or in its discretion to deduct from the Contract price or consideration, or otherwise recover the full amount of such commission, percentage, brokerage, or contingent fee.

V.41 CONTRACT-033.1 Applicable Law (Oct 2006)

This Contract shall be governed by and interpreted and enforced in accordance with the laws of the Commonwealth of Pennsylvania (without regard to any conflict of laws provisions) and the decisions of the Pennsylvania courts. The Contractor consents to the jurisdiction of any court of the Commonwealth of Pennsylvania and any federal courts in Pennsylvania, waiving any claim or defense that such forum is not convenient or proper. The Contractor agrees that any such court shall have in personam jurisdiction over it, and consents to service of process in any manner authorized by Pennsylvania law.

V.42 CONTRACT- 034.1b Integration (Nov 30 2006)

This Contract, including the Invitation for Bids, the Contractor's bid, all referenced documents, and any Purchase Order constitutes the entire agreement between the parties. No agent, representative, employee or officer of either the Commonwealth or the Contractor has authority to make, or has made, any statement, agreement or representation, oral or written, in connection with the Contract, which in any way can be deemed to modify, add to or detract from, or otherwise change or alter its terms and conditions. No negotiations between the parties, nor any custom or usage, shall be permitted to modify or contradict any of the terms and conditions of the Contract. No modifications, alterations, changes, or waiver to the Contract or any of its terms shall be valid or binding unless accomplished by a written amendment signed by both parties.

V.43 CONTRACT-034.2b Order of Precedence - IFB (Dec 6 2006)

In the event there is a conflict among the documents comprising this Contract, the Commonwealth and the Contractor agree on the following order of precedence: the Contract; the IFB; and the Contractor's Bid in Response to the IFB.

V.44 CONTRACT-034.3 Controlling Terms and Conditions (Aug 2011)

The terms and conditions of this Contract shall be the exclusive terms of agreement between the Contractor and the Commonwealth. All quotations requested and received from the Contractor are for obtaining firm pricing only. Other terms and conditions or additional terms and conditions included or referenced in the Contractor's quotations, invoices, business forms, or other documentation shall not become part of the parties' agreement and shall be disregarded by the parties, unenforceable by the Contractor and not binding on the Commonwealth.

V.45 CONTRACT-035.1a Changes (Oct 2006)

The Commonwealth reserves the right to make changes at any time during the term of the Contract or any renewals or extensions thereof: 1) to increase or decrease the quantities resulting from variations between any estimated quantities in the Contract and actual quantities; 2) to make changes to the services within the scope of the Contract; 3) to notify the Contractor that the Commonwealth is exercising any Contract renewal or extension option; or 4) to modify the time of performance that does not alter the scope of the Contract to extend the completion date beyond the Expiration Date of the Contract or any renewals or extensions thereof. Any such change shall be made by the Contracting Officer by notifying the Contractor in writing. The change shall be effective as of the date of the change, unless the notification of change specifies a later effective date. Such increases, decreases, changes, or modifications will not invalidate the Contract, nor, if performance security is being furnished in conjunction with the Contract, release the security obligation. The Contractor agrees to provide the service in accordance with the change order. Any dispute by the Contractor in regard to the performance required by any notification of change shall be handled through Contract Controversies Provision.

V.46 CONTRACT-037.1a Confidentiality (Oct 2013)

(a) The Contractor agrees to protect the confidentiality of the Commonwealth's confidential information. The Commonwealth agrees to protect the confidentiality of Contractor's confidential information. In order for information to be deemed confidential, the party claiming confidentiality must designate the information as "confidential" in such a way as to give notice to the other party (notice may be communicated by describing the information, and the specifications around its use or disclosure, in the SOW). Neither party may assert that information owned by the other party is such party's confidential information. The parties agree that such confidential information shall not be copied, in whole or in part, or used or disclosed except when essential for authorized activities under this Contract and, in the case of disclosure, where the recipient of the confidential information has agreed to be bound by confidentiality requirements no less restrictive than those set forth herein. Each copy of such confidential information shall be marked by the party making the copy with any notices appearing in the original. Upon termination or cancellation of this Contract or any license granted hereunder, the receiving party will return to the disclosing party all copies of the confidential information in the receiving party's possession, other than one copy, which may be maintained for archival purposes only, and which will remain subject to this Contract's security, privacy, data retention/destruction and confidentiality provisions (all of which shall survive the expiration of this Contract). Both parties agree that a material breach of these requirements may, after failure to cure within the time frame specified in this Contract, and at the discretion of the non-breaching party, result in termination for default pursuant to the DEFAULT provision of this Contract, in addition to other remedies available to the non-breaching party.

(b) Insofar as information is not otherwise protected by law or regulation, the obligations stated in this Section do not apply to information:

- (1) already known to the recipient at the time of disclosure other than through the contractual relationship;
- (2) independently generated by the recipient and not derived by the information supplied by the disclosing party.
- (3) known or available to the public, except where such knowledge or availability is the result of unauthorized disclosure by the recipient of the proprietary information;
- (4) disclosed to the recipient without a similar restriction by a third party who has the right to make such disclosure; or
- (5) required to be disclosed by law, regulation, court order, or other legal process.

There shall be no restriction with respect to the use or disclosure of any ideas, concepts, know-how, or data processing techniques developed alone or jointly with the Commonwealth in connection with services provided to the Commonwealth under this Contract.

(c) The Contractor shall use the following process when submitting information to the Commonwealth it believes to be confidential and/or proprietary information or trade secrets:

- (1) Prepare an un-redacted version of the appropriate document, and
- (2) Prepare a redacted version of the document that redacts the information that is asserted to be confidential or proprietary information or a trade secret, and
- (3) Prepare a signed written statement that states:
 - (i) the attached document contains confidential or proprietary information or trade secrets;
 - (ii) the Contractor is submitting the document in both redacted and un-redacted format in accordance with 65 P.S. § 67.707(b); and
 - (iii) the Contractor is requesting that the document be considered exempt under 65 P.S. § 67.708(b)(11) from public records requests.
- (4) Submit the two documents along with the signed written statement to the Commonwealth.

V.47 CONTRACT-046.1 Manufacturer's Price Reduction (Oct 2006)

If, prior to the delivery of the awarded item(s) by the Contractor, a price reduction is announced by the original equipment manufacturer, a comparative price reduction will be given to the Commonwealth by the Contractor.

V.48 CONTRACT-047.1 Motor Vehicles to be manufactured in North America (Oct 2006)

All motor vehicles furnished by the Contractor pursuant to the Contract must be manufactured in North America. North America is defined as the United States, Canada, and Mexico. A motor vehicle is manufactured in North America if a substantial majority of the principal components are assembled into the final products in an assembly plant in North America. The Contractor shall be prepared to prove that the motor vehicles that will be, or have been, furnished to the Commonwealth will be or are, in fact, manufactured in North America in accordance with Sections 3731-3736 of the Commonwealth Procurement Code (62 Pa. C.S. Sections 3731-3736), known as the Motor Vehicle Procurement Act. No payment shall be made to the Contractor unless the Commonwealth is satisfied that the Contractor has complied with these provisions and the Motor Vehicle Procurement Act. Any payments made to the Contractor, which should not have been made, shall be recoverable directly from the Contractor. In addition to the withholding of payments, any person who willfully violates any of the provisions of the Motor Vehicle Procurement Act may be prohibited by any public agency from participation in Contracts awarded by the public agency for a period of five years from the date of determination that a violation has occurred.

V.49 CONTRACT-047.2b General Delivery Requirements for Vehicles (Oct 2012)

The Contractor must supply the contracted vehicles that are to be delivered to the Commonwealth of Pennsylvania in accordance with the specifications attached to this IFB and any Pennsylvania Commercial Item Descriptions referenced in the specifications and attached to this IFB.

V.50 CONTRACT-051.1 Notice (Dec 2006)

Any written notice to any party under this Contract shall be deemed sufficient if delivered personally, or by facsimile, teletype, electronic or digital transmission (provided such delivery is confirmed), or by a recognized overnight courier service (e.g., DHL, Federal Express, etc.) with confirmed receipt, or by certified or registered United States mail, postage prepaid, return receipt requested, and sent to following:

- a. If to the Contractor: the Contractor's address as recorded in the Commonwealth's Supplier Registration

system.

b. If to the Commonwealth: the address of the Issuing Office as set forth on the Contract.

V.51 CONTRACT-052.1 Right to Know Law (Feb 2010)

a. The Pennsylvania Right-to-Know Law, 65 P.S. §§ 67.101-3104, (“RTKL”) applies to this Contract. For the purpose of these provisions, the term “the Commonwealth” shall refer to the contracting Commonwealth agency.

b. If the Commonwealth needs the Contractor’s assistance in any matter arising out of the RTKL related to this Contract, it shall notify the Contractor using the legal contact information provided in this Contract. The Contractor, at any time, may designate a different contact for such purpose upon reasonable prior written notice to the Commonwealth.

c. Upon written notification from the Commonwealth that it requires the Contractor’s assistance in responding to a request under the RTKL for information related to this Contract that may be in the Contractor’s possession, constituting, or alleged to constitute, a public record in accordance with the RTKL (“Requested Information”), the Contractor shall:

1. Provide the Commonwealth, within ten (10) calendar days after receipt of written notification, access to, and copies of, any document or information in the Contractor’s possession arising out of this Contract that the Commonwealth reasonably believes is Requested Information and may be a public record under the RTKL; and
2. Provide such other assistance as the Commonwealth may reasonably request, in order to comply with the RTKL with respect to this Contract.

d. If the Contractor considers the Requested Information to include a request for a Trade Secret or Confidential Proprietary Information, as those terms are defined by the RTKL, or other information that the Contractor considers exempt from production under the RTKL, the Contractor must notify the Commonwealth and provide, within seven (7) calendar days of receiving the written notification, a written statement signed by a representative of the Contractor explaining why the requested material is exempt from public disclosure under the RTKL.

e. The Commonwealth will rely upon the written statement from the Contractor in denying a RTKL request for the Requested Information unless the Commonwealth determines that the Requested Information is clearly not protected from disclosure under the RTKL. Should the Commonwealth determine that the Requested Information is clearly not exempt from disclosure, the Contractor shall provide the Requested Information within five (5) business days of receipt of written notification of the Commonwealth’s determination.

f. If the Contractor fails to provide the Requested Information within the time period required by these provisions, the Contractor shall indemnify and hold the Commonwealth harmless for any damages, penalties, costs, detriment or harm that the Commonwealth may incur as a result of the Contractor’s failure, including any statutory damages assessed against the Commonwealth.

g. The Commonwealth will reimburse the Contractor for any costs associated with complying with these provisions only to the extent allowed under the fee schedule established by the Office of Open Records or as otherwise provided by the RTKL if the fee schedule is inapplicable.

h. The Contractor may file a legal challenge to any Commonwealth decision to release a record to the public with the Office of Open Records, or in the Pennsylvania Courts, however, the Contractor shall indemnify the Commonwealth for any legal expenses incurred by the Commonwealth as a result of such a challenge and shall hold the Commonwealth harmless for any damages, penalties, costs, detriment or harm that the Commonwealth may incur as a result of the Contractor’s failure, including any statutory damages assessed against the Commonwealth, regardless of the outcome of such legal challenge. As between the parties, the Contractor agrees to waive all rights or remedies that may be available to it as a result of the Commonwealth’s disclosure of Requested Information pursuant to the RTKL.

i. The Contractor’s duties relating to the RTKL are continuing duties that survive the expiration of this Contract and shall continue as long as the Contractor has Requested Information in its possession.



COMMONWEALTH OF PENNSYLVANIA
PENNSYLVANIA COMMERCIAL ITEM DESCRIPTION (PCID)

General Requirements for Delivery of Vehicles

(This item description supersedes PCID 1067, effective April 12, 2011)

PCID NO. 1067

Eff. 8/19/14

The following delivery requirements shall apply to the vehicle as specified by the ordering agency. These requirements are in addition to, but not limited to, the vehicle specification provided as part of the solicitation document. Unless otherwise noted on the request for proposals or invitation for bids, deliveries shall be made to the Department of General Services (DGS), Commonwealth Garage, 22nd and Forster Streets, Harrisburg, Pennsylvania, phone (717) 787-4252.

NOTE: Deliveries for the Department of Transportation (PennDOT) shall be made to the PennDOT Equipment Division, headquartered in Harrisburg, Pennsylvania, phone (717) 787-2123. Deliveries for the Pennsylvania State Police (PSP) shall be made to the PSP Transportation Division headquartered in Harrisburg, Pennsylvania, phone (717) 787-1318.

1.0 GENERAL REQUIREMENTS SECTION

1.1 The vehicle Manufacturer's model name and/or model number shall be indicated on a decal affixed inside the door.

1.2 Standard solid exterior colors with standard interior trim shall be selected after the award is made unless otherwise indicated in the proposal.

1.3 Tire size and type shall be original equipment brand or as indicated in the proposal or specification sheet. Tire inflation monitors shall be supplied as required by Federal Motor Vehicle Safety Standard (FMVSS) 138.

1.4 All vehicles shall be new and of the model year indicated in the proposal.

1.5 All vehicles shall include all genuine parts, accessories and equipment considered standard by the manufacturer for the vehicle offered by the supplier.

1.6 All vehicles shall have a valid PA state inspection sticker and a valid PA emissions inspections sticker (for all vehicles subject to the PA I/M Program). NOTE: New or current model year vehicles with less than 5,000 miles, subject to the PA I/M program, must display a valid PA emissions inspection sticker with an exemption indicator. All Pennsylvania state inspection requirements are the sole responsibility of the supplier.

1.7 All vehicles shall have completed the manufacturers' recommended pre-delivery service.

1.8 All vehicles shall be clean, lubricated, serviced, fuel tank filled to full recommended capacity, all adjustments completed, all mechanical and electrical components fully functional and operational, and the vehicle will be "road ready" for immediate use.

NOTE: Supplier shall not remove the manufacturer's MSRP (Monroney) sticker and/or dealer sticker price prior to delivery. Stickers should be affixed to an interior surface of the vehicle window and legible from outside of the vehicle. Stickers shall be easily removable without any permanent marking left on the glass. Incomplete chassis shall have the sticker included loose with the delivery documents.

1.9 All vehicles shall have appropriately placed decals or manuals indicating the types of required fuels or lubricants and the capacity of each fluid's reservoir in accordance with the manufacturer's recommendation.

Vehicle Delivery Requirements

PCID NO. 1067

1.10 All vehicles shall have permanent antifreeze in each vehicle to protect it at a level of -35°F.

1.11 All vehicles shall be free from all dealer signs/emblems.

1.12 All vehicles shall have all required rust proofing applied to the exterior and underside of the vehicle. No rustproofing compound can be on the personnel compartment's items or the exterior of the body in unsightly or unintended areas.

1.13 All vehicles shall include a copy of the manufacturer's warranty and service policy with all warranty vouchers, certificates and coupons.

1.14 Each vehicle shall include the proper forms to apply for Pennsylvania title and license including the original manufacturer's Statement of Origin signed by the dealer/supplier and notarized. All title papers shall be properly executed and include PennDOT Form MV-1, Application for Title, which shall indicate the owner name and address as follows: **Pennsylvania Department of General Services, 2221 Forster Street, Harrisburg, Pa 17125.***

*VEHICLES DELIVERED TO PA DEPT OF TRANSPORTATION SHALL BE TITLED ACCORDINGLY.

1.15 At the time of vehicle delivery, the successful supplier shall furnish an original and three copies of the invoice which shall include the key number, vehicle color and Commonwealth purchase order number, contract number (if applicable) and indicate ordering agency. To ensure prompt payment the dollar amount of the supplier's invoice must match the purchase order amount.

1.16 The successful supplier shall comply with the manufacturer's warranty, or authorize a qualified dealer in the locality in which the unit is assigned to do whatever is required to comply with the manufacturer's warranty.

1.17 The successful supplier shall submit at least two (2) copies of all service/technical bulletins, recall notices, etc. to the Director, Bureau of Vehicle Management, Department of General Services, 2221 Forster Street, Harrisburg, Pennsylvania 17125. These documents shall be submitted on a continual basis to keep the Bureau of Vehicle Management informed regarding improvements, changes and/or problems concerning Commonwealth owned vehicles and their component parts.

1.18 The Department of General Services, Bureau of Vehicle Management, will inspect all vehicles prior to acceptance. It will be the responsibility of the supplier to remove any vehicle rejected by the Bureau of Vehicle Management within two (2) working days after notification, and return the vehicle to the Commonwealth Garage upon correction of deficiencies. Date in service will be the date the vehicle is accepted by the Commonwealth, not the date of delivery.

1.19 The Commonwealth disclaims any liability for damage to vehicles not unconditionally accepted by the Commonwealth.

1.20 Unless otherwise indicated, all items requested in this specification which are listed in the manufacturer's specification book as standard or optional equipment shall be factory installed and operative. Vehicles delivered to the Commonwealth in a condition considered to be below retail customer acceptance levels will not be accepted. Items which determine this acceptance level shall include, but not be limited to, the general appearance of the interior and exterior of the vehicle for completeness and quality of workmanship, lubrication and fluid levels, with any leaks corrected, mechanical operation of the vehicle and all electrical components operational. Allied equipment specified to be furnished and installed which is not available through the vehicle manufacturer shall conform to the best quality standards known to that particular industry, both product and installation.

1.21 Trucks with snow plows being delivered to the Commonwealth Garage for inspection, are required to have the snow plow stored in the truck bed. Failure to do so will show cause for rejection of inspection.

1.22 All vehicle deliveries shall be coordinated through the DGS Bureau of Vehicle Management. Suppliers shall call (717) 787-4252 for delivery schedule at least 48 hours in advance. When vehicles are purchased by Pennsylvania State Police, the successful supplier shall call (717) 787-1318 (PSP). When vehicles are purchased by Pennsylvania

Vehicle Delivery Requirements

PCID NO. 1067

Department of Transportation, the successful supplier shall call (717) 787-2123 (PennDOT) for information regarding invoicing and delivery.

1.23 Vehicle Delivery: Mileage limitations are placed upon vehicles delivered in accordance to these requirements as indicated below. If the mileage upon delivery exceeds these limits, a credit of \$5.00 per mile will be applied against the awarded supplier's purchase order as damages and deducted at time of payment. If the awarded supplier uses a towing device to tow another vehicle to the Commonwealth Garage for delivery, the towing device may not be attached in a way that holes are drilled in the bumpers of the vehicles being towed. Drilling of holes in the vehicle bumpers is not permitted. Any bumper damage caused by a towing device will be replaced by the awarded supplier at no charge to the Commonwealth. If a vehicle is being towed by another vehicle, the vehicle being towed must have the drive shaft disconnected to eliminate unnecessary mileage.

1.23.1 Class 1 to 3 factory completed vehicles: mileage displayed on the vehicle odometer shall not exceed 400 miles.

1.23.2 Class 2 to 6, factory incomplete vehicle: mileage displayed on the vehicle odometer upon delivery with final stage manufacturer certification shall not exceed 1,000 miles.

1.24 Pennsylvania Clean Vehicles Program Requirement: Supplier is responsible to ensure that all supplied vehicles are compliant with all applicable Title 25 requirements (25 Pa. Code, Chapter 126, Subchapters D or E). This compliance shall be evidenced on the manufacturer's certificate of origin (MCO), or, alternatively, by submission of a completed MV-9. If supplied vehicles are not compliant, they can not be titled in Pennsylvania and the delivering supplier shall be responsible to pick up and return the vehicle by replacing it with a California or "50-state" emissions certified vehicle that is compliant with all Title 25 requirements

2.0 REQUIRED EQUIPMENT SECTION

The following items shall be supplied on all vehicles as **Minimum** required equipment, unless otherwise superceded in the request for proposals or invitation for bids.

2.1 Lug wrench on all trucks and jacks on trucks up to and including 10,000 lbs. GVWR.

2.2 Air conditioning integral with the heater and defrosters.

2.3 Dual electric intermittent windshield wipers.

2.4 The rustproofing shall be factory or locally applied in compliance with Federal Standard 297A. Warranty coupon for five (5) years, at no cost to the Commonwealth, shall be furnished with each vehicle*.

* NOT APPLICABLE IF THE VEHICLE FURNISHED IS FACTORY WARRANTED AGAINST CORROSION FOR NOT LESS THAN 5 YEARS AT NO COST TO THE COMMONWEALTH OF PENNSYLVANIA. WARRANTY INDICATING COMPLIANCE IS REQUIRED WITH EACH VEHICLE.

2.5 Emergency warning triangle kit (on vehicles with GVWR of 10,000 lbs. or higher; aftermarket installation if necessary).

2.6 First aid kit, 10 person with mountable cabinet (on vehicles with GVWR of 10,000 lbs. or higher; aftermarket installation if necessary).

2.7 Fire extinguisher, rechargeable, with vehicle mount, reference 2A:10B:C, 5 pound (on vehicles with GVWR of 10,000 lbs. or higher; aftermarket installation if necessary).

2.8 Powerport.

2.9 Unless otherwise indicated on the purchase order, each vehicle shall be equipped with front and rear license plate holders with a minimum two license plate screws installed.

2.10 Back-up alarm on all vehicles with GVWR of 10,000 lbs. or higher.

Vehicle Delivery Requirements

PCID NO. 1067

2.11 If a flexible fuel or an alternate fuel option is offered by the manufacturer, it shall be provided at no additional charge.

3.0 MATERIAL MASTERS: No Material Masters established for this delivery PCID.

Quality Assurance Specialist: Gerald Grecek, CPPB

Quality Assurance Supervisor: Brian Vulgaris

Division Chief: Janice Pistor



COMMONWEALTH OF PENNSYLVANIA
PENNSYLVANIA COMMERCIAL ITEM DESCRIPTION (PCID)

GENERAL REQUIREMENTS FOR BIDDING PennDOT VEHICLES/EQUIPMENT

(This item description supersedes PCID No. 1075 eff. 3/9/11)

PCID NO. 1075
 Eff. 12/7/11

These General Requirements shall apply to all on-road and off-road vehicles, highway equipment, agricultural equipment and construction equipment, procured for use by the Department of Transportation, Commonwealth of Pennsylvania (PennDOT). These requirements are in addition to any supplemental specifications identified in the invitation for bids. The following shall be considered MINIMUM requirements.

A. STANDARDS, CODES, RULES, REGULATIONS:

1. Each vehicle or unit of equipment shall conform to any and all requirements contained in the Pennsylvania Motor Vehicle Code.
2. Each vehicle or unit of equipment shall comply with all current applicable Federal Motor Vehicle Safety Standards, Federal and Pennsylvania Exhaust Emission and Noise Standards, and EPA and OSHA requirements. The appropriate decals indicating compliance shall be affixed to the vehicle/equipment.
3. Each vehicle or unit of equipment shall be manufactured in accordance with any codes, standards and engineering practices as recommended by the following professional organizations for the specific vehicle/equipment:

American Institute of Steel Construction (AISC)
 American National Standards Institute (ANSI)
 American Society of Mechanical Engineers (ASME)
 American Society for Testing and Materials (ASTM)
 American Trucking Association (ATA)
 American Welding Society (AWS)
 American Wood-Preservers Association (AWPA)
 Battery Council International (BCI)
 British Standards Institute (BSI): Limits and Fits
 Compressed Air and Gas Institute (CAGI)
 Industrial Fastener Institute (IFI)
 International Standards Organization (ISO)
 Joint Industrial Council (JIC)
 National Fire Protection Association (NFPA)
 National Truck and Equipment Association (NTEA)
 Power Crane and Shovel Association (PSCA)
 Society of Automotive Engineers (SAE)
 Society of Manufacturing Engineers (SME)
 Steel Structure Painting Council (SSPC)
 Tire and Rim Association (TRA)

B. COMPONENTS, PARTS AND ACCESSORIES:

1. When "No Substitute" components, parts or accessories are designated, only this type of component, part or accessory is acceptable.
2. All equipment and parts furnished shall be of the manufacturer's most current design, shall be included in its most current published list of models in stock and shall satisfy, these specifications.
3. The same model components shall be utilized on all units supplied by the successful bidder under the specifications.
4. All electronic systems associated with the vehicle/equipment shall be properly insulated so as not to not cause any interference with the operation of the vehicle or the land mobile radio communications system, when properly installed in the vehicle.
5. Power systems must be compatible with the engine, transmission, axles, hydraulic system and power steering, etc., in order to meet the requirements specified herein.
6. Vehicles shall meet the maximum gradeability of the manufacturer when loaded to maximum Gross Vehicle Weight Rating ("GVWR") without exceeding the engine manufacturer's recommended maximum revolutions per minute ("RPM") based on maximum net torque.
7. The ratio of the rear axle and transmission shall be geared to maintain a road speed of approximately 65 mph on a level road, when operating at maximum GVWR without exceeding the recommended engine rpm figure. This is not applicable to construction type equipment.

C SITE VISITS:

Prior to submission of its bid, a bidder may contact PennDOT and schedule a site visit to inspect vehicles/equipment (as available) in PennDOT's current inventory in order to further clarify any drawings, pictures and specifications. Units may be available in the field for bidders to inspect at one or more of PennDOT's Maintenance Districts, but the Commonwealth makes no guarantee that any particular vehicle/equipment shall be located at a site convenient to the bidder's place of business. The site visit must be scheduled with the Equipment Division by calling (717) 783-2371. It is the bidder's responsibility to complete the site visit in time to submit a bid. All travel will be at the bidder's expense.

D. ON BOARD VEHICLE/EQUIPMENT REQUIREMENTS:

1. Each vehicle and unit of equipment shall include the proper forms to apply for a Pennsylvania title and license. These forms will include: the original manufacturer's statement of origin signed by the successful bidder and notarized. A detailed invoice listing all equipment, PO number, VIN numbers and price. All title papers shall be properly prepared and executed. The application for title, Form MV-1 shall indicate the name and address exactly as follows: Pa. Dept. of Transportation, Equipment Division, 17th Street and Arsenal Blvd., Harrisburg, PA 17120 (ATTN: Specifications Unit).
2. Trucks and trailers shall be certified to meet or exceed requirements to obtain a Pennsylvania license. For medium and heavy-duty trucks and vans, the GVWR shall be identified in the vehicle's cab as the final complete certification label (minimum rating). The Gross Combined Weight Rating (GCWR) shall be identified by decal in the cab to indicate the approved weight, which can be towed, if applicable.
3. Vehicles designated for on-road/off-road use shall meet the following requirements:
 - a. Shall have a valid Pennsylvania state inspection sticker, if applicable.
 - b. Shall have completed the manufacturers' recommended pre-delivery service.
 - c. Shall have the vehicle manufacturer's model name and model number stated on a decal affixed to the inside of the driver's side door, if applicable.

- d. Shall be clean, lubricated, serviced, fuel tank filled to full recommended capacity, all adjustments completed, all mechanical and electrical motors and components fully functional and operational, and the vehicle will be “work ready” for immediate use.
- e. Shall have appropriately placed decals indicating the types of required fuels or lubricants and the capacity of each fluid’s reservoir that is required by the vehicle.
- f. Shall have permanent antifreeze in each vehicle to protect it at a level of -35°F. Only a low silicate type anti-freeze will be used for vehicles having diesel engines.
- g. Shall be free from all dealer signs/emblems.
- h. Hydraulic systems shall be compatible with Universal Tractor Fluid (UTF).
- i. Shall include a copy of the manufacturer's warranty and service policy with all warranty vouchers, certificates and coupons as in accordance with section E (GENERAL WARRANTY REQUIREMENTS) as listed below.
- j. Shall have each vehicle and major component identified with a metal identification tag that provides the OEM's name, model number and individual serial number. Tags will be affixed in an accessible and readable position on the item.

The above items are pre-delivery service items, and bidders should not misconstrue these requirements with warranty problems that arise after the Commonwealth accepts the completed unit which complies with the written specifications.

All charges for any of the aforementioned administrative and technical services and equipment are considered minimum acceptable requirements for delivery and shall be included in the bid price.

E. GENERAL WARRANTY REQUIREMENTS

The following warranty requirements are considered minimum unless otherwise stated in the invitation for bids. If the manufacturer's standard warranty exceeds the specified warranty, the manufacturer's standard warranty will apply. Manufacturer's warranty shall be provided in written or electronic form. All warranties will cover all labor and parts replacement, **without deductibles** during the warranty period, except as may be otherwise stated below or in the invitation for bids. This warranty, however, does not include items that must be replaced through ordinary wear and tear, but those parts ordinarily replaced through the servicing program will be replaced as part of the servicing program of equipment/vehicles, if appropriate. Parts replaced under this warranty will be of original equipment manufacturer (OEM) quality or higher. Service to the vehicle/equipment will be at a level to maintain or meet the manufacturer's requirements to sustain the warranty. All warranty policies shall be from the OEM and repairs shall be made at any authorized OEM warranty repair facility. Multiple repair facilities shall be located regionally around the State to support warrantable repairs.

- 1. A. CONSTRUCTION EQUIPMENT: The construction and agricultural equipment manufacturer's service and warranty program for full machine (“bumper to bumper”) shall be for a minimum of two (2) years or two thousand (2,000) hours whichever first occurs.
- 1. B. CONSTRUCTION EQUIPMENT: The construction and agricultural equipment manufacturer's service and warranty program for full machine (“bumper to bumper”) shall be for a minimum of one (1) year.
- 2. A. LIGHT DUTY TRUCKS & VANS (up to 19,500# GVWR):

The chassis and cab manufacturer's service and warranty program shall be for three (3) years or 36,000 miles (whichever first occurs), including powertrain. A two (2) year, unlimited mileage warranty is acceptable in lieu of a three year, 36,000-mile warranty. The vehicle shall be certified as having a capacity of towing 5,000 pounds minimum without voiding the warranty.

2. B. MEDIUM DUTY/HEAVY DUTY CAB & CHASSIS (19,501# GVWR or higher):

The chassis manufacturer's service and warranty program shall be for one (1) year or 12,000 miles (whichever first occurs).

3. ADDITIONAL SPECIFIC WARRANTY ITEMS (Applies to light, medium and heavy duty trucks only)

a. RUST PROOFING WARRANTY

Cabs/cowls shall be warranted for five (5) full years with no mileage or hourly limitations. This will include rusting through or perforation from within. This warranty and service program covers both labor and parts for the full warranty period. Surface rust caused by chip, scratches, or damage caused by PennDOT employees is not covered by this warranty.

b. FRAME RAILS AND CROSSMEMBERS (Chassis)

For medium/heavy duty trucks, frame rails and cross members are warranted for five (5) full years with no mileage or hourly limitations. This warranty covers both parts and labor for the full warranty period. For light duty trucks and vans, the manufacturer's standard frame rail and crossmember warranty is acceptable.

c. FLAT BED WARRANTY

A vehicle's flat bed shall be warranted for three (3) years. This warranty covers both parts and labor for the full warranty period. A decal will be placed on the inside driver's door stating the warranty's terms and the name, address and telephone number of the contact person to initiate warranty claim services.

d. SERVICE/UTILITY BODY AND ASSOCIATED COMPONENTS WARRANTY

Fiberglass bodies shall be warranted for five (5) years to include color fading. Steel service and utility bodies shall be warranted for five (5) years against defects and corrosion, including rust through or perforation from within. Surface rust caused by chip, scratches, or damage caused by PennDOT employees is not covered by this warranty. Associated components such as cranes, air compressors, and snowplows shall be covered by manufacturer's standard warranty. Manufacturer's standard warranty shall be provided in written or electronic form.

e. ENGINE AND TRANSMISSION WARRANTY

The engines for all Heavy/Medium Duty equipment/vehicles will be warranted for parts and labor for five (5) years or 150,000 miles (whichever first occurs). The engine warranty will include all items named or included within the valve covers, cylinder heads, block and oil pan. The transmission (automatic/manual) will be fully covered by the warranty and service program for five (5) years and will not be limited by mileage or hours. For light duty trucks and vans, the manufacturer's standard frame engine and transmission warranty is acceptable. Electronic fuel delivery components, electronic control modules and emission control components shall be covered for five (5) years or 100,000 miles whichever first occurs. After treatment Device/DPF shall be warranted for minimum 5 years or 100,000 miles. In addition to the engine warranty, the engine block shall be warranted against external perforation from corrosion for 10 years, 100% parts and labor.

f. WARRANTY CARD PROCEDURES

The successful bidder shall complete the warranty card except for the warranty start date. The PennDOT Equipment Division shall inform the successful bidder of the following: model number of vehicle; serial number of vehicle, equipment number, and location assigned; date released to

the counties. The warranty start-up date shall be the date of acceptance by the Department, not the date of delivery to the Department.

F. PILOT MODEL:

PennDOT reserves the right to require the successful bidder to make mutually agreeable arrangements to deliver a “pilot model” for initial inspection. Pilot models(s) shall be delivered to the Department of Transportation, 17th St., & Arsenal Blvd., Harrisburg, PA 17120 for inspection, testing and approval. The remaining units shall not be delivered for inspection, testing and approval until after the pilot model has been accepted by PennDOT. The remaining units shall fully meet the requirements of the specifications and must be indistinguishable from the approved pilot model. Presentation of a pilot model will not be required if the quantity is only one (1) unit. The pilot model must meet all the mechanical requirements of the specifications. PennDOT may field test the equipment to determine if it meets the performance requirements of the specifications. Performance testing results will normally be completed within two (2) weeks of date of delivery. There are administrative items that are required to be presented at the pilot model inspection. It is imperative that all of these items be presented at this time so they are ready for shipment, when the balance of the units are delivered. PennDOT may withhold payment, where deemed necessary, pending receipt of these items. PennDOT disclaims any liability for damage to equipment that has not been unconditionally accepted by the PennDOT.

G. DELIVERY:

Time is of the essence. All units must be delivered within the number of days, specified in the invitation for bids, after receipt of the purchase order by the successful bidder. It shall be assumed by the parties that the successful bidder received the purchase order on the third business day following the date of the purchase order, unless the successful bidder provides credible evidence that the order was received on a later date. Bidders must specify delivery time in their bid. Phrases such as “as required”, “as soon as possible”, or “prompt” have no meaning and may be cause for rejection of the bid. The successful bidder shall deliver **the completed unit(s) at ground level (stacked loads are unacceptable)** to the Equipment Division, 17th Street and Arsenal Blvd. Harrisburg, PA 17120. All deliveries shall be made on a working day between 7:00 AM and 2:30 PM. There is a loading dock at this location; however, any additional unloading cost shall be borne by the successful bidder. The terms of delivery are also controlled by other provisions in the invitation for bids.

The successful bidder shall submit to the PennDOT “on a continuing basis”, all service bulletins and technical letters as regularly issued by a manufacturer to dealers or large fleets. All the relevant information shall be supplied for the unit(s) forwarded to the Commonwealth to inform PennDOT of any improvements, changes and/or problems concerning the unit and its component parts. This information shall be addressed to the Pennsylvania Department of Transportation, Equipment Division, 17th St. & Arsenal Blvd., Harrisburg, PA 17120, ATTN: Specification Unit Chief, Equipment Division. PennDOT reserves the right to have its representative(s) periodically inspect each unit during assembly at the successful bidder’s assembly point.

H. PROCEDURE FOR IMPLEMENTING REPAIRS:

In the event that a breakdown occurs, the repair work is to be performed by the successful bidder of record or his duly authorized representative within the Commonwealth. A copy of the successful bidder's work orders shall be supplied to the PennDOT County Equipment Manager and District Equipment Manager. Repairs assigned to the successful bidder can be performed at the successful bidder’s place of business, at his duly authorized representative’s place of business and, whenever possible, at the county maintenance facility or field locations. If services are to be performed at PennDOT’s county maintenance facilities or in the field, the successful bidder must provide proof of insurance as stated in the contract attachments. County Equipment Managers shall notify the successful bidder or his duly authorized service representatives that the vehicle/equipment is down for component repairs and follow PennDOT standard procedure for handling warranty problems in accordance with the benefits of this warranty. At this time of notification, the location of repair is to be mutually agreed upon based on the most timely and cost effective basis to the Department. All work orders against the warranted repair shall be kept in PennDOT’s Equipment History File at the county maintenance facility.

When repairs are to be performed at the successful bidder’s place of business or his duly authorized representative’s place of business, transportation of the vehicle/equipment within the Commonwealth of Pennsylvania shall be made by PennDOT. If determined by PennDOT that repairs cannot be handled within the Commonwealth, then transportation to and from the Commonwealth of Pennsylvania shall be the responsibility of the successful bidder.

If mileage costs will be charged to the Department for the diagnosis or repair of a warrantable item, an estimate of these costs shall be given to the County Equipment Manager prior to the repair agreement.

I. LUBRICATION AND COMPONENT INFORMATION:

The successful bidder shall provide lubrication and component information (as applicable) upon request by PennDOT. This information may be provided by copying and completing the sample forms attached to this document, or may be presented on forms prepared by the successful bidder and/or manufacturer. (see attached sample forms – 4 pages).

J. SUCCESSFUL BIDDER'S RIGHTS:

The successful bidder shall have the right to make periodic inspections to ascertain that the maintenance techniques and/or repair procedures are being administered in accordance with the guidelines set forth in this document. Preventive maintenance shall be performed by PennDOT in accordance with the component manufacturer's recommended procedures, or as modified during the contract through supplements. All internal parts of the components shall be the repair responsibility of the successful bidder, except maintenance adjustments.

K. MATERIAL MASTERS: No Material Masters established for this delivery PCID.

APPROVALS:

Quality Assurance Specialist: Gerald Grecek, CPPB

Quality Assurance Manager: Janice Pistor

Sample Forms (Instruction Sheet)

The Following Documents Shall Be Completed And Emailed / Shipped To

Email: Contact the Automotive Equipment Specialist @ The Equipment Division @ 717-705-2124 (This is an Excel Spread Sheet, a Work Copy will be Emailed to You)

**Mail: Equipment Division
17th & Arsenal Blvd.
Harrisburg, Pa. 17120
Attn: Specifications Division**

Note: These Forms Must Be Delivered to The Equipment Division With The Pilot Model!

**Instructions To Vendor For Completing The Attached Form
(We Would Prefer Having This Completed Electronically)**

Electronic:

- 1. Obtain Work Copy By Calling 717-705-2124**
- 2. All Sections Are to be Filled Out**
- 3. Insert N/A in All Sections That Do Not Apply, Do Not Leave any Sections Blank**
- 4. Manufacturer, Model No. And Part No. Should Reflect The Actual Component Manufacturer**
- 5. Warranty Section Should Reflect The Coverage, The Vendor And/Or Equipment (Truck) Manufacturer Will Supply, Not The Component Manufacturer.**

Paper:

- 1. Same As Above, but Type or Print All Information**

LUBE AND COMPONENT SHEET

Equipment # Series		Effective Date						
PO Number		Unit Warranty Period						
Year		Engine Manufacturer						
Make		Engine Model						
Model								
VIN Number								
Vendor		Trans. Manufacturer						
Contact Person		Trans. Model						
Contact Phone Num.		Body Manufacturer						
		Body Number						
Oils & Lubes		Filters	Qty. of Filters	Part Number	Com. Code 2810-	Make	Change Interval	Filters Stocked
Engine Oil		Engine Oil Filter						
		Engine Oil Filter Secondary						
Transmission Oil		Transmission Filter						
		Aux. Trans. Filter						
Fuel		Fuel Filter Primary						
		Fuel Filter Secondary						
Rear Axle / Axles								
Steering Oil		Steering Filter						

Hydraulic Oil		Hydraulic Filter Suction						
		Hydraulic Filter Return						
Coolant		Coolant Filter						
Transfer Case								
Front Axle		Air Filter Primary						
Brake Fluid		Air Filter Secondary						
		Air Compressor Filter						
Description	Manufacturer	Model Number	Part Number				Warranty	
Air Compressor								
Air Dryer								
Alternator								
Auto Slack Adjuster								
Auto Lube System								
Axle Front								
Axle Rear								
Battery								
Belt Air Compressor								
Belt Alternator								
Belt Fan								
Belt Power Steering								
Brake Chamber (FRT)								
Brake								

Chamber (REAR)				
Brake Lining (FRT)				
Brake Lining (REAR)				
Clutch Assembly				
Differential				
Dump Body				
Electronic Joysticks				
Engine (AUX)				
Engine (MAIN)				
Fan				
GL 400				
GL 400 Wiring				
Grote Wiring Harness				
Hoist Cylinder				
Hydraulic Pump - Main				
Pump, Fuel				
Pump, Hydraulic Aux.				
Pump, Steering				
Pump, Water				
Radiator				
Rexroth Valve				
Starter				
Steering Gear				
Suspension System				

Tank Fuel Capacity				
Tire Size Front LR				
Tire Size Rear LR				
Transaxle				
Transfer Case				
Transmission				
Wing Plow				